



**DIBBLE STICKS,
DONKEYS, AND
DIESELS**

**MACHINES IN
CROP PRODUCTION**

Joseph K. Campbell

Department of Agricultural and
Biological Engineering
Cornell University
Ithaca, New York, USA

1990

International Rice Research Institute
P. O. Box 933, Manila, Philippines

The International Rice Research Institute (IRRI) was established in 1960 by the Ford and Rockefeller Foundations with the help and approval of the Government of the Philippines. Today IRRI is one of the 13 nonprofit international research and training centers supported by the Consultative Group on International Agricultural Research (CGIAR). The CGIAR is sponsored by the Food and Agriculture Organization (FAO) of the United Nations, the International Bank for Reconstruction and Development (World Bank), and the United Nations Development Programme (UNDP). The CGIAR consists of 50 donor countries, international and regional organizations, and private foundations:

IRRI receives support, through the CGIAR, from a number of donors including the Asian Development Bank, the European Economic Community, the Ford Foundation, the International Development Research Centre, the International Fund for Agricultural Development, the OPEC Special Fund, the Rockefeller Foundation, the United Nations Development Programme, the World Bank, and the international aid agencies of the following governments: Australia, Belgium, Brazil, Canada, China, Denmark, Finland, France, Federal Republic of Germany, India, Iran, Italy, Japan, Republic of Korea, Mexico, The Netherlands, New Zealand, Norway, the Philippines, Saudi Arabia, Spain, Sweden, Switzerland, United Kingdom, and United States.

The responsibility for this publication rests with the International Rice Research Institute.

Copyright© International Rice Research Institute 1990

All rights reserved. Except for quotations of short passages for the purpose of criticism and review, no part of this publication may be reproduced, stored in retrieval systems, or transmitted in any form or by any means, electronic, mechanical, photocopying, recording, or otherwise, without prior permission of IRRI. This permission will not be unreasonably withheld for use for noncommercial purposes. IRRI does not require payment for the noncommercial use of its published works, and hopes that this copyright declaration will not diminish the bona fide use of its research findings in agricultural research and development.

The designations employed and the presentation of the material in this publication do not imply the expression of any opinion whatsoever on the part of IRRI concerning the legal status of any country, territory, city, or area, or of its authorities, or the delimitation of its frontiers or boundaries.

ISBN 971-104-185-5

Contents

	Introduction	1
	Why mechanization?	1
	Units and their use	3
CHAPTER 1	Human and Animal Power	5
	1.1 Relationships among energy, work, and power	5
	1.2 Human power	7
	1.3 Animal power	9
	1.3.1 Bullocks	14
	1.3.2 Water buffalo	21
	1.3.3 Elephants	23
	1.3.4 Horses	23
	1.3.5 Mules	32
	1.3.6 Donkeys	33
	1.3.7 Camels	33
	1.3.8 Llamas	36
	1.4 Rotary power from animals	37
CHAPTER 2	Mechanical Power	41
	2.1 Engine power	41
	2.2 Tractor horsepower	44
	2.3 Single-axle pedestrian tractor	45
	2.4 Double-axle pedestrian tractor	50
	2.5 Compact tractor	51
	2.6 Farm tractor	53
	2.7 Single-wheel pedestrian tractor	66
	2.8 Motorcycle tractor	67
	2.9 Winch system	68
CHAPTER 3	Agricultural Production Systems	73
	3.1 Climate, soil, and farming systems	73
	3.2 Shifting cultivation	74
	3.3 Polyculture	77
	3.4 Monoculture	79
	3.5 Cropping calendars	81
	3.6 Soil tilth and compaction	81

CHAPTER 4 Tillage 89

- 4.1 Tillage tool classification **89**
- 4.2 Hoes **90**
- 4.3 Spades and shovels **91**
- 4.4 Foot plows **93**
- 4.5 Ards **94**
- 4.6 Chisel plows **96**
- 4.7 Field cultivators **99**
- 4.8 Subsoilers **99**
- 4.9 Moldboard plows **101**
- 4.10 Disk plows **110**
- 4.11 Laying out a field for plowing **111**
- 4.12 Rotary tillage tools **111**
- 4.13 Harrows **115**
- 4.14 Puddlers **124**

CHAPTER 5 Planting 129

- 5.1 Tools for planting large seeds **129**
- 5.2 Tools for planting small seeds **136**
- 5.3 Tools for planting cuttings and tubers **142**
- 5.4 Tools for planting seedlings **147**

CHAPTER 6 Fertilization 153

- 6.1 Rate of manure production by animals **154**
- 6.2 Hand tools for applying manure **154**
- 6.3 Machines for spreading manure **155**
 - 6.3.1 Box spreaders **155**
 - 6.3.2 Flail spreaders **158**
 - 6.3.3 Closed-tank spreaders **158**
- 6.4 Machines for applying chemical fertilizer **159**
 - 6.4.1 Dry fertilizer **160**
 - 6.4.2 Liquid fertilizer **163**

CHAPTER 7 Weed Control 167

- 7.1 Mechanical weed control **167**
 - 7.1.1 Manual tools **168**
 - 7.1.2 Animal- and tractor-powered machines **170**
- 7.2 Chemical weed control **174**

CHAPTER 8 Insect and Predator Control 183

- 8.1 Mechanical control **183**
- 8.2 Chemical control **185**

CHAPTER 9 Harvesting 189

- 9.1 Grain harvesting **189**
 - 9.1.1 Hand tools **190**
 - 9.1.2 Reapers **196**
 - 9.1.3 Threshers **199**
 - 9.1.4 Combines **205**
- 9.2 Root and tuber harvesting **211**
- 9.3 Forage harvesting **217**
 - 9.3.1 Hand tools **217**
 - 9.3.2 Mowing machines **218**
 - 9.3.3 Conditioners and rakes **221**
 - 9.3.4 Forage harvesters **227**
 - 9.3.5 Hay balers **231**
- 9.4 Fiber harvesting and field processing **235**
 - 9.4.1 Cotton **235**
 - 9.4.2 Jute **238**
 - 9.4.3 Kenaf **239**
 - 9.4.4 Flax **239**
 - 9.4.5 Coir **241**
 - 9.4.6 Sisal **241**
 - 9.4.7 Albaca **243**

CHAPTER 10 Grain Drying and Storage 247

- 10.1 Basic principles **247**
- 10.2 Cribs **251**
- 10.3 Drying with heat **253**
- 10.4 Drying with forced air **257**
- 10.5 Resistance of grain to airflow **258**
- 10.6 Fan characteristics **260**
- 10.7 Combined forced-air and heat drying systems **261**

CHAPTER 11 Transport 273

- 11.1 Manual transport **273**
 - 11.1.1 Carrying pole **274**
 - 11.1.2 Bicycles **277**
 - 11.1.3 Wheelbarrows and handcarts **278**
- 11.2 Animal transport **281**
- 11.3 Tractors **285**

CHAPTER 12 Social Consequences 291

- 12.1 Mechanization and agricultural employment **291**
- 12.2 Mechanization and crop yield **293**
- 12.3 Mechanization and farm income **295**
- 12.4 Affordable technology **295**
- 12.5 Mechanization and quality of life **297**

Foreword

Dibble Sticks, Donkeys, and Diesels: Machines in Crop Production is a broad study of agricultural mechanization, from simple hand tools to self-propelled harvesters. The book is for the non-agricultural engineer who wants to learn about the wide diversity of power and machines used by farmers to produce our staple food and fiber crops. It provides the reader with information needed to weigh the advantages and disadvantages of specific types of machines. For example, what are the trade-offs between a pedestrian tractor and a hydrotiller? Why are short-handled hoes used in Africa? For human transport of loads, why is the limber bamboo carrying stick of Asia superior to the rigid poles used in some other countries?

The author, Joseph K. Campbell, answers these and many other questions in this survey of technological development in crop production. Over the last 100 years, the shift from muscle to engine power has changed agriculture dramatically. Often ignored, however, is the fact that most of the farmers in the world still depend on animal power as their main source of draft energy.

The lessons learned in recent decades are important to document. We now know that direct transfer of knowledge from one environment to another often leads to wrong solutions to critical problems. At the same time, it is most valuable to know how, when, where, and why technological change took place. With this information, the adaptation of knowledge and the development of technological solutions according to local needs are easier to achieve.

Not many people today have the combined skills to compile the kind of information found in this book. Professor Campbell has more than 40 years of worldwide experience in agriculture. He was born into a family of Pennsylvania

x FOREWORD

farmers and learned about crop production literally from the ground up. He chose agricultural engineering as his profession, earning his bachelor's degree at Pennsylvania State University and his master's at Cornell University. Since 1967 he has been on the faculty of Cornell, where he is Professor of Agricultural Engineering. He worked as an in-house consultant at the International Potato Center in Peru and spent two years at the International Rice Research Institute in the Philippines. Short-term consultancies have taken him to Bangladesh, Ecuador, Egypt, Ghana, Kenya, Nigeria, Pakistan, Paraguay, and Zaire. Professor Campbell has also had extensive practical experience as a design engineer for a leading manufacturer of agricultural implements.

Dibble Sticks, Donkeys, and Diesels will be a valuable resource for development workers, economists, extension officers, administrators, students, and agriculturalists throughout the developed and developing world.

Klaus Lampe
Director General

Introduction

Why mechanization?

In industrial countries, mechanization lowers crop production costs by replacing labor with machines. It is therefore reasonable to question the desirability of mechanization in less developed countries (LDCs), which usually have large, untapped sources of labor and small farms.

Crops are produced by the interaction of sunlight, water, and nutrients. Man can utilize energy to improve conditions for crop growth. For example, the manipulation of plant spacing can affect the efficiency of solar energy in producing food through photosynthesis. However, a small plot utilizing mechanization may produce no more than the same plot farmed solely by sufficient human energy.

Increased food production is often linked to mechanization. Unlike a factory, a farm is at the mercy of natural phenomena such as water, temperature and daylength, over which the farmer has little control. The farmer's ability to cultivate within the time provided by the rhythms and whims of nature determines the adequacy of crop yield. Approximately the same amount of work is required to prepare the soil for planting, whether accomplished by a man fueled by rice, a water buffalo fueled by forage, or a tractor fueled by petroleum. In many countries, tillage must be carried out during the rainy season because neither farmers with hoes nor animal-drawn plows have sufficient power to till hard, dry soil. Mechanization in the form of an animal-drawn steel plow or a tractor, however, can prepare the soil before the rains to

2 INTRODUCTION

permit either a longer growing period or more than one annual crop.

The relationship between social structure and mechanization is not always obvious. Substituting a 100-horsepower (hp) tractor with a seven-bottom plow for a 50-hp tractor with a three-bottom plow makes sense to a New York dairy farmer on a family farm where the work force consists of the father, two or three children, and a hired man. Dairy cattle require care throughout the year, but at peak periods there is increased demand for labor for fieldwork, plowing, planting, and harvesting. The large machines allow this farmer to plow seven furrows simultaneously instead of three, and to harvest maize for forage at a rate of 40 tons per hour (t/h) instead of 15 t/h. This farmer's use of power and mechanization is economically advantageous since planting can be accomplished during the few days the soil is suitable in the spring, and harvesting can be completed before fall rains cause crop losses. Of course, a farmer's capital or a nation's resources can be wasted through inappropriate mechanization.

Mechanization of small holdings in LDCs with high rates of unemployment or underemployment is a difficult problem. Often the extended family is the primary social system. A person is responsible not only for his parents and siblings, but for aunts, uncles, and cousins. Since there is little opportunity to earn a wage away from the family farm in this type of social system, labor is often augmented by distant relatives. The farmer must provide them food and shelter whether or not they work. What matters to the workers is not lack of employment, but lack of food. What determines their standard of living is not underemployment but the total farm production. In such cases, mechanization benefits all concerned if it increases total farm production.

In addition to improved plant varieties, water management, fertilizers, credit, and government food pricing policies, appropriate mechanization plays an essential part in increasing food production and the standard of living in rural areas.

Climatic conditions in the developed countries of the temperate zone generally permit only one grain crop per year. In the north temperate zone, much of the land is dormant from the first frost in October to the last frost in May. These

conditions are not worldwide. One should not consider agricultural problems with a bias in favor of the agricultural practices of one area. Although one grain crop per year is the norm in the temperate zone, in the sunny, frost-free tropics, food crops can be grown throughout the year.

Where more than one crop per year is cultivated, it is important to reduce the time between harvest of one crop and planting of the next. For example, a 125-d rice variety, yielding 3,000 kg/ha per crop, has a cost of 24 kg/ha for each day the land is idle. Therefore the use of machinery to speed land preparation and planting of the next crop provides an additional 24 kg rice/ha for each day saved in establishing the next crop.

Units and their use

Metric or English? In general, North American farmers use the English system of measurement, and European farmers use the metric system. Mixtures of the two systems, and local units of measurement are used throughout the world. For example, Peru is officially metric, but its citizens use hectares, meters, and kilograms (metric,) as well as board feet, horsepower, and national fine and national course screw threads (English).

Adding to the confusion is the existence of more than one metric system. For many years, the word kilogram has been used as the unit for both mass and force. This caused few practical problems for agriculturists since they work on the earth's surface where gravity is 1 g, and kilogram mass (kg) and kilogram force (kgf) are numerically the same. In 1960, however, the 11th General Conference of Weights and Measures adopted an expanded metric system called "Le Systeme International d'Unites" (SI), SI expresses mass in kilograms, but force is expressed in newtons.

In the interest of universal comprehension, when non-SI systems of measurement are used in this book (either for understanding or because the original research was conducted in such units), the SI equivalent is given in parentheses. For example, a test of a compact tractor revealed that under specific conditions the tractor provided a pulling force of 948 pounds. This will be expressed as 948 lb (4,217 N, 430 kgf).

4 INTRODUCTION

These primary units of measurement are used in this book:

Dimension	Metric SI	Metric kg force	English
Length	meter	meter	foot
Area	hectare	hectare	acre
Mass	kilogram	kilogram of mass	slug
Force	newton	kilogram of force	pound
Energy	joule	joule	foot-pound or calorie
Work	joule	kilogram-meter	foot-pound
Heat	joule	calorie	British thermal unit
Power	watt	watt	horsepower
Temperature	degree Celsius	degree Celsius	degree Fahrenheit
Pressure	pascal	kilogram/centimeter squared	pounds/square inch

Time is expressed in minutes (min), hours (h), days (d), weeks (wk), month (mo), and years (yr).

English-to-metric conversion factors are listed in Appendix A.

1 Human and animal power

Land cannot be tilled, seed cannot be planted, and crops cannot be harvested without energy. The various forms of human and animal power and the means of harnessing them for agriculture, as well as their characteristics, advantages, and limitations, are discussed in this chapter.

1.1 Relationships among energy, work, and power

This book uses the words force, work, power, and energy in the engineering sense.

A *force* can be visualized as a pull or push that tends to move an object. For example, a force of 2500 N (255 kgf, 562 lb) is required to move a plow through the soil. In tillage tools, this force is usually referred to as *draft*. Whether the plow is pulled a meter or a mile, the required draft in this example is 2500 N.

The term *work* includes the dimensions of force and distance. Work equals force multiplied by distance. The metric SI unit of work is the joule (J), and the metric kilogram force unit is kilogram-meter (kg-m). The English unit is the foot-pound (ft-lb). The time required to do a job is not part of the definition of work. To plow one hectare of land requires the same amount of work whether the job is completed in a day or an hour. However, the power requirements are very different.

Powers is the rate at which work is performed. The faster the work is done, the greater the power requirement. In the English system, horsepower is the power unit. One horsepower equals 33,000 ft-lb/min. Horsepower is the rate at which a large draft horse can perform work. When the 18th century Scotsman, James Watt, was designing steam engines, he was faced with prospective customers insisting on know-

6 HUMAN AND ANIMAL POWER

ing the precise number of horses that could be replaced by one of his engines. Accordingly, Watt experimented with draft horses and determined the power generated by a horse exerting a constant 150-lb pull while walking 2 1/2 miles per hour (mph). Watt called this amount of power “one horsepower.”

The common units of power in the metric system are the kilowatt (kW) and the metric horsepower. Metric horsepower is also known as *pferde starke* (ps). One metric horsepower (ps) equals 4500 kg (force)-m min.

$$\begin{aligned}1\text{ kW} &= 1,000 \text{ N-m/sec} \\1\text{ hp} &= 550 \text{ ft-lb/sec} \\1\text{ ps} &= 75 \text{ kgf-m/sec} \\1\text{ hp} &= 745.7 \text{ N-m/sec} \\1\text{ hp} &= 1.014 \text{ ps} = 0.746 \text{ kW} \\1\text{ ps} &= 0.986 \text{ hp} = 0.735 \text{ kW}\end{aligned}$$

For example, if the plow in our example is pulled with a force of 2500 N (255 kgf, 562 lb) for a distance of 500 m (1640 ft) in 10 min, the power expended at the plow would be:

$$\text{kW} = \frac{2500 \text{ N} \times 500 \text{ m}}{600\text{sec}} \div 1000 \text{ N-m/sec per kW} = 2.08 \text{ kW}$$

$$\text{ps} = \frac{255 \text{ kg} \times 500 \text{ m}}{600\text{sec}} \div 75 \text{ kg(force)-m/sec per ps} = 2.83 \text{ ps}$$

$$\text{hp} = \frac{562 \text{ lb} \times 1640 \text{ ft}}{600\text{sec}} \div 550 \text{ ft-lb/sec per hp} = 2.79 \text{ hp}$$

Metric horsepower and English horsepower are nearly equal. This book will therefore use the term *horsepower* rather than *kilowatt*, since it is easier to visualize a large draft horse than 0.746 kW.

Energy, heat, and work are expressed in joules in the SI system. However, it is common to express energy and heat in special units - the calorie (c) in the metric kilogram force system and the British thermal unit (BTU) in the English system. The BTU is the quantity of heat required to raise the temperature of 1 lb of water 1 °F. The kilocalorie is the quantity of heat required to raise 1 kg of water 1 °C. The

7 DIBBLE STICKS, DONKEYS, AND DIESELS

calorie (1/1000 kilocalorie) is used in some disciplines and is represented by a lowercase "c." The kilocalorie is represented by a capital "C."

1.2 Human power

Man develops a total power of 0.5 hp from the food he eats. However, only 0.1 hp is available for useful work. The remainder is expended on bodily functions (basal metabolism). This norm is based on an adequately fed 35-year-old male European laborer working an 8-h day and 48-h week. A man of 20 can generate approximately 15% more useful energy than the norm, and a 60-year-old about 20% less.

Based on the above norm, an equation for useful power for work lasting from 4 min to 8 h can be expressed by the equation: $hp = 0.35 - 0.092 \log t$ where t is in minutes.

Work period	4 min	15 min	30 min	1 h	2 h	4 h	6 h	8 h
Power (hp)	0.29	0.24	0.21	0.19	0.16	0.13	0.11	0.10

The equation predicts that a man can provide work at the rate of nearly 0.3 hp for 5 min, but at only 0.1 hp over 8 h. A man's muscles also provide an overload energy capability of approximately 0.6 hp-min. For bursts of energy for less than one second, up to 6 hp may be expended.

Pedaling makes use of the large leg muscles (Fig. 1.1). For periods of time from 1 to 100 minutes, a man pedaling can generate useful power of 0.27-0.53 hp. This is expressed by the equation: $hp = 0.53 - 0.13 \log t$ where t is in minutes.¹

Work period	1 min	10 min	15 min	30 min	45 min	1 h	1.5 h	1.7h
Power (hp)	0.53	0.40	0.38	0.34	0.32	0.30	0.28	0.27

A person can exert approximately 55 kgf (120 lb, 540 N) by pushing or pulling. Using carrying supports, a person can carry a load equal to his own weight for short distances of about 50 m (165 ft). For long distances, the load should not exceed half a person's weight.

Humans require energy in the form of food. Food energy of 2000 C per day is minimal input. Conversion efficiency is the ratio of useful energy from the person to the food energy consumed. The highest conversion efficiency is 25%. Human work efficiency decreases under hot and humid conditions. for humans as well as machines conform to the laws of thermodynamics. Human efficiency decreases when the

8 HUMAN AND ANIMAL POWER

ability to dissipate heat through evaporation, convection, or radiation is diminished by tropical climate. Humans cannot compete successfully with animals or engines as a source of power for repetitive jobs such as pumping water for irrigation. A human is at a disadvantage because of low power output. A person is unique, however, because of intelligence. For jobs having low power requirements but demanding decisionmaking and manual dexterity, humans are well adapted. For example, transplanting vegetables or rice demands dexterity of hand as well as thought. Does the transplant have sufficient roots? Is the spacing correct? A person transplants better than machines or animals.

1.1. Human-powered treadle pump in Bangladesh.

Although the reader will probably not be called upon to act as an energy source in agriculture, an attempt to under-

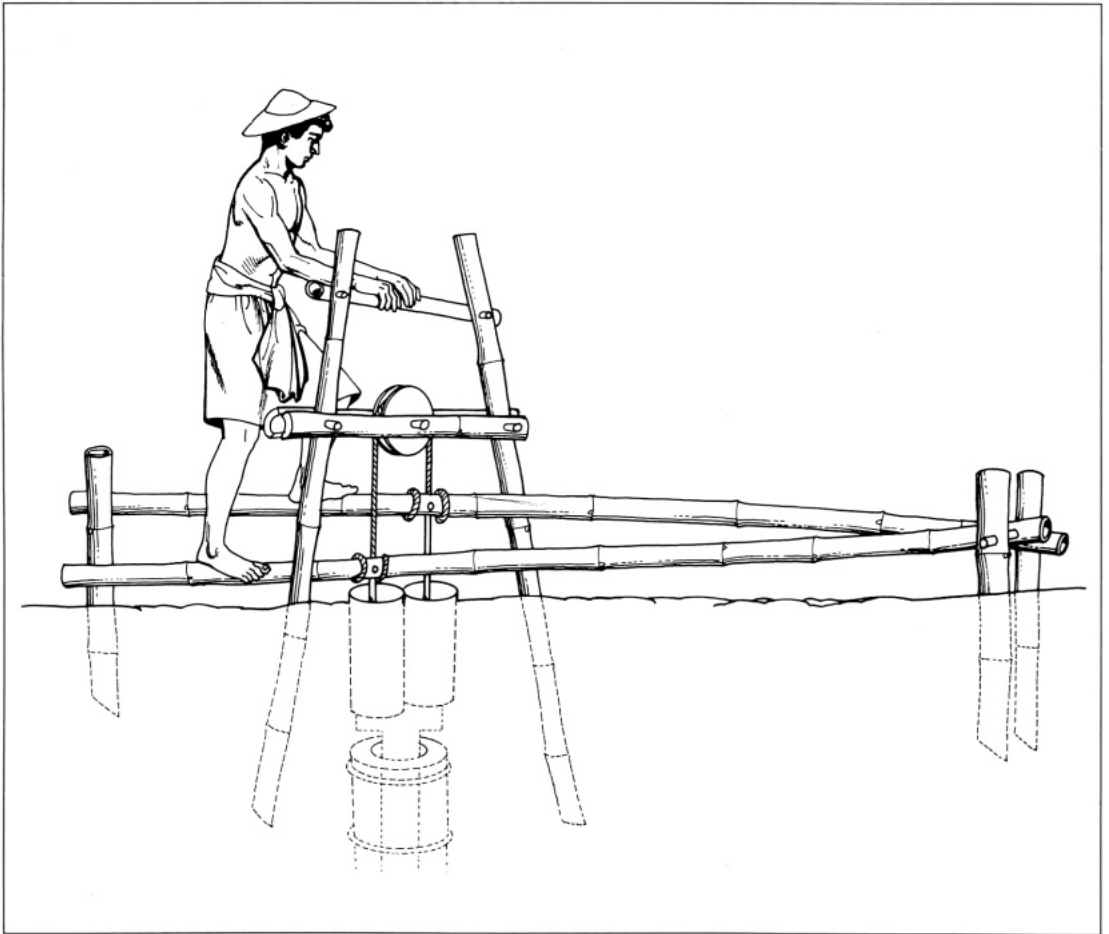

stand the position of the Third World farmer, whose own energy is the power source for the farm, would be informative. The farmer is probably underfed, suffering from parasites, working under the hot sun, and aware that the work will be hard not only today, but also tomorrow, the day after, and the day after that. A water pump designed for poor farmers in LDCs may be a lark to operate at an exhibition in Washington, D.C., where the visitor operates it for only several minutes, but it will not be viewed so idealistically by farmers in the LDCs.

1.3 Animal power

The large domesticated four-footed animals commonly called draft animals are an essential source of power in agriculture. Draft animals provide approximately 80% of the world's agricultural draft requirements. Table 1.1 lists the world's draft animal and tractor population by region.

Draft is a suitable term for animals used in agriculture, for the animal's strength is nearly always converted to useful work by the animal pulling against a load, whether it be an ox pulling against a head yoke or a horse, against its collar or breaststrap. Oxen, water buffalo, horses, and mules are the primary draft animals. Camels and donkeys are more typically used as pack animals, although they are used for pulling carts and plows in some countries,

An animal can do four things that a tractor cannot do: feed itself, maintain itself, be trained for automatic control, and

Table 1.1. Total number of tractors and selected animals in the world.²

Region	Number						
	Cattle	Water buffalo	Horses	Mules	Donkeys	Camels	Tractors
North and Central America	186,849,000	8,000	18,664,000	4,040,000	3,239,000	-	5,485,060
USA ^a	114,040,000	-	10,300,000	1,000	4,000	-	4,550,000
South America	251,717,000	720,000	13,363,000	3,193,000	3,950,000	-	4,550,000
Europe	134,235,000	409,000	4,916,000	479,000		1,186,000	9,047,313
Africa	175,588,000	2,410,000	3,684,000	2,259,000	12,200,000	12,797,000	493,069
Asia	373,963,000	122,224,000	16,965,000	5,307,000	18,950,000	4,160,000	4,086,589
Oceania	30,634,000	-	579,000		12,000	-	428,755
USSR ^b	119,558,000	330,000	5,700,000	2,000	330,000	250,000	2,697,000
World	1,272,541,000	126,102,000	63,871,000	15,279,000	39,866,000	17,207,000	22,916,527

^aUSA population is included in North and Central America.

^bUSSR population is not included in Asia or Europe.

reproduce itself. Viewing the draft animal as a machine, we see a jointed framework held together with ligaments and muscles. The engine consists of the digestive organs, while the excretory system carries away waste products. The brain and nervous system provide a control system with a memory bank and logic circuits. Joints and moving parts have a sealed lubricating system. Protecting the mechanism is a skin and hair covering resistant to damage, and self-healing if the damage is minor.

The energy efficiency of animals is the subject of considerable disagreement. The Food and Agriculture Organization (FAO) states that the energy efficiency is 9-10% for bovines and 10-12% for the horse family³ P.S. Rose, on the other hand, states that the horse has an efficiency of about 20% and man 19.6%.⁴ The difference between these authorities is probably due to the means by which work is obtained from the animal, whether by draft or by a treadmill. The efficiency of energy conversion is 20-35% for gasoline and diesel engines.

Generally, a draft animal's force is approximately 10% of its weight. Horses have a higher output than other animals. Unlike a tractor, an animal cannot be worked continuously. The period during which an animal can be worked daily usually varies from 8 to 10 h for horses and mules, and from 6 to 8 h for adult oxen. Table 1.2 lists the normal draft and power of various draft animals. It is impossible to provide precise data for draft animals, since performance depends on individual characteristics such as breed, weight, sex, age, health, training, and quality of feed.

Just as an internal combustion engine requires high quality petroleum fuel to perform well, an animal requires a sufficient amount of high quality fuel in the form of feed in order to develop maximum power. The availability of feed affects the choice of draft animal. For example, the horse is usually preferred to the ox because of the former's greater speed, maneuverability, and power output. Oxen can work satisfactorily on low quality forage, however. A horse must have grain to perform well. Slicher van Bath, in *The Agrarian History of Western Europe*, states that in Europe, when tools and social conditions made possible a shift from a two-course rotation (land left fallow in alternate years) to a three-course rotation (where land lay fallow one year out of three), a larger oat harvest could be produced, making it possible to feed a

Table 1.2. Draft and horsepower of various animals⁵

Animal	Average weight (kg)	Approximate draft in kgf (lb)	Average speed (km/h)	Horsepower developed
Bullock	500 - 900	60-80 (130-175)	2.0-3.0	0.75
Cow	400 - 600	50-60 (110-130)	2.5	0.45
Water buffalo	400 - 900	50-80 (110-175)	2.9-3.2	0.75
Light horse	400 - 700	60-80 (130-175)	3.6	1.0
Mule	350 - 500	50-60 (110-130)	3.2-3.6	0.7
Donkey	200 - 300	30-40 (65-90)	2.5	0.35
Camel ⁶	450 - 500	40-50 (90-110)	4	0.67
Man	60 - 90	30 (65)	1	0.1

greater number of horses.⁷ He further notes that during times of increasing agricultural prosperity a shift occurs from oxen to horses. He lists several explanations for this:

- The pace of an ox is slower than that of a horse, so an ox does much less work. But the ox is cheaper to feed. The ox saves food, while the horse saves man-hours. Sixteenth century French writers stated that one horse could do as much work in a day as three or four oxen. Especially in a damp climate, the speed at which certain tasks can be accomplished is of vital concern.
- Newly reclaimed land is often poorer and lighter and therefore easier to work.
- The higher cash profit for cereals during a period of reclamation allows farmers to spend more on haulage-power.
- During a boom, social prestige plays a greater part. A farmer with horses stands higher in the social scale than one who keeps only oxen.⁸

Neither high draft nor high speed by itself indicates high power output. Power is the product of draft and speed.

$$\text{hp} = \frac{\text{draft (lb)} \times \text{speed (mph)}}{375 \text{ lb-mph}}$$

or

$$\text{hp}_{\text{metric}} = \frac{\text{draft (kgf)} \times \text{speed (km/h)}}{270 \text{ kg-km/h}}$$

12 HUMAN AND ANIMAL POWER

For example, a particular ox may pull a load with a force of 80 kgf (176 lb, 785 N), while a horse may pull with a force of only 60 kgf (132 lb, 588 N); but the horse with that particular load moves at 3.5 km/h, while the ox moves at 2 km/h. Under these conditions the horse provides 0.8 hp and the ox 0.6 hp.

Animals can, over a short period of time, develop much higher power than that produced during normal work. For example, a good pair of draft horses can develop 20-25 hp for 10 sec, while a yoke of good oxen can generate 20-30 hp over a distance of 100 m. Excessive overloading, however, will harm the animals.

The energy of the animals is converted to useful work by the harness. A poorly designed and ill-fitting harness not only reduces the power available from the animal, but causes the animal to suffer by chafing or interfering with breathing.

When draft greater than can be provided by one animal is required, two or more animals are harnessed together to pull as a team. An efficiency loss for the individual animal results when harnessed in a team. When harnessing animals of equal strength together, the draft of the individual should be multiplied by 1.9 for two animals, 2.5 for three, 3.1 for four, 3.5 for five, and 3.8 for six. For example, if one ox can provide a draft of 600 N (61 kgf, 135 lb), then a yoke of 2 oxen can provide 1.9×600 N or 1140N. If 6 oxen are yoked together, the draft is 2280 N—only double that of 2 oxen. Animals of the same breed, age, fitness, and training should be used in a team. Otherwise, the weak or ill-trained individual will reduce the team's output.

Figure 1.2 shows an evener used to hitch three draft animals to one implement. The points where the singletrees pivot on the evener provide several closely spaced holes for the pins securing the singletree. These holes allow for adjustments in the length of the lever arm against which an animal is pulling. Allowances can thus be made for weaker or stronger members of the team so the evener is not pulled askew.

It is easier to pull a load on the level than up a slope. since on a slope the load must be lifted as well as pulled forward. The draft of an animal is therefore reduced when pulling a load up a slope. The angle of the slope is usually referred to as percent grade, which is defined as units of vertical rise per 100 units of horizontal distance. For example, a rise of 1 m

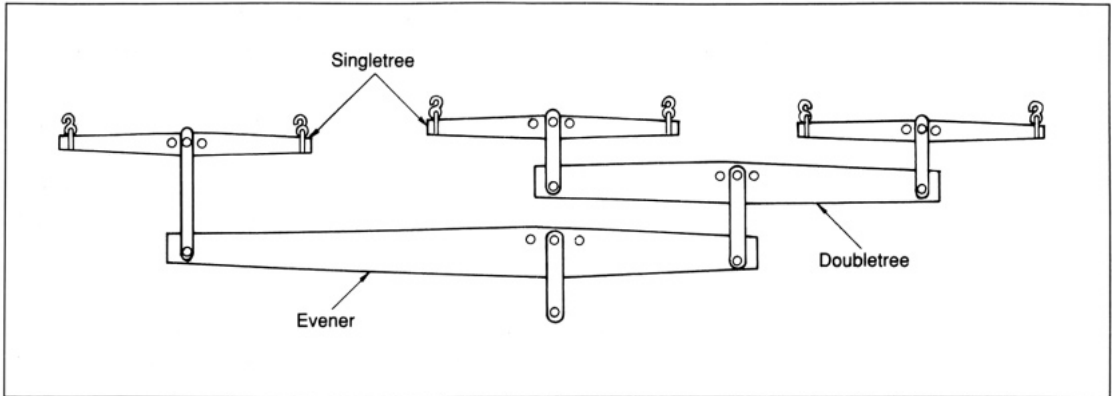

1.2. Evener for a team.

per 100 m horizontal distance is a 1%) grade. The draft of a horse is reduced by 10% on a 1% grade, 20% on a 2% grade, 35% on a 3.3% grade, 60% on a 5% grade, and 75% on a 10% grade.⁹ Draft requirements for some farming operations are given in Appendix B.

Brody has examined data on men and horses working at various levels of effort. His work enables one to estimate the power output of draft animals of various sizes and conditions. If the power a draft animal can produce during heavy work over a 6- to 10-h day considered 1, the maximum power maintained for 5-320 minutes is 4 times as great and the maximum power that can be exerted over a few seconds is 25 times as great.¹⁰

In general, power produced by draft animals such as bullocks, horses, water buffalo, and elephants can be estimated by their mass in relation to man.

$$hp_A = hp_M \times \left(\frac{\text{mass}_A}{\text{mass}_M} \right)^{0.73}$$

where: A = animal M = man

Using the previously stated estimate for man's power output,

$$hp_A = (0.35 - 0.092 \log t) \times \left(\frac{\text{mass}_A}{\text{mass}_M} \right)^{0.73}$$

Tractors develop less than their designed capacity because of mechanical maladjustments or failures. Draft animals are subject to biological problems and breakdowns. Horses

and cattle cannot be used in one-fourth of Africa, for example, because of the disease trypanosomiasis, which is spread by the tsetse fly, a bloodsucking insect of the genus *Glossina*.¹¹ The tsetse and its accompanying trypanosomiasis parasites affect Equatorial Africa south of the Sahara in a band from about 15° N to 20° S latitude. Trypanosomiasis (popularly known as sleeping sickness) debilitates and kills thousands of humans and animals each year. In animals, the parasites are *Trypanosoma brucei*, *Trypanosoma congolense*, and *Trypanosoma vivax*. In humans, the parasites are *Trypanosoma gambiense* and *Trypanosoma rhodesiense*. Although zebu cattle are susceptible to trypanosomiasis, some breeds such as N'dama and Muturu have some tolerance for the disease.

Foot and mouth disease kills both cattle and water buffalo. In 1975, an outbreak in the Philippines, accompanied by government guaranteed loans for agricultural machinery, resulted in very rapid spread of pedestrian tractors to replace the affected animals.¹²

1.3.1 Bullocks. The terms ox, bullock, and steer are used to describe a castrated bovine (Fig. 1.3). The terms ox and bullock apply to animals trained for draft purposes. Uncastrated bulls are strong, but frequently unmanageable. Cows lack strength. The bullock, therefore, with its strength and manageability, is preferred. It is important that bullocks selected for purchase have good temperament. Sound feet and legs with free action are also necessary attributes. The

1.3. Nomenclature of an ox.

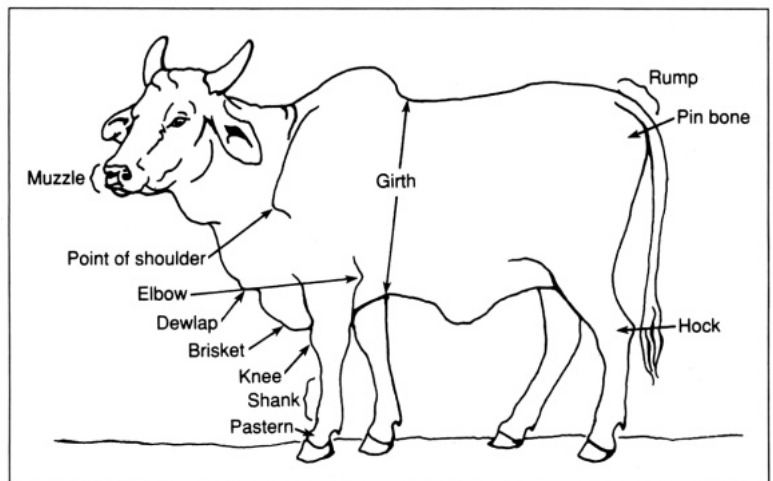

feet should be large with solid, hollow-soled hooves.

An ox to be used with a head yoke requires a short, powerful neck and thick nape. Its horns should be medium length, angled forward, and set in a wide head. If the animal is to be used with a shoulder yoke, its shoulders should be solid rather than sloping, and it should have a hump to help keep the yoke in place.

Bullocks should be trained for draft work when 2-3 yr old. A typical training program is shown in Appendix C. If well managed, a draft bullock should perform satisfactorily for about 17 yr.

Cultivation trials using N'dama bullocks in Gambia revealed that work in excess of 5 h/d can be sustained only over a few days. After 3 h of heavy morning work, each bullock lost an average of 25 kg. With adequate pasturing, the bullocks normally recovered, but at times the losses were cumulative and affected the bullocks' health. A double head yoke was used in the trials. The work and power output of a bullock depend on body weight, hours of continuous work, and climate.¹³

At the International Crops Research Institute for the Semi-Arid Tropics (ICRISAT) in Hyderabad, India, tests¹⁴ revealed that trained and adequately fed Indian bullocks (*Bos indicus*) of the Hallikar breed, 8-14 yr old, could pull maximum draft loads of 13-16% of their body weight for a 6-h period. During a 6-h working day, the average speed, power, and work output were 3 km/h, 0.9 hp, and 14.0 megajoules (5.2 hp-h) of work per pair.

The speed, power, and work output increased with body weight. Although power and work output increased with additional draft load, there was a proportionate rate of decrease in speed. At maximum draft load, moreover, the bullocks could not work as many hours per day. Speed and power decreased as the hours of continuous work increased. At the end of 6 h of continuous work, speed and power were reduced by 75%.

The vertical force of a yoke on a pair of draft bullocks should be kept below 60 kgf (575 N, 132 lb) to prevent excessive stress.

The Indian bullocks also performed better in a cool, dry climate (26°C, 35% relative humidity [RH]) than in a warm, humid climate (29°C, 57% RH).

Bullocks for draft purposes are usually harnessed in pairs or multiple pairs.

The harness is the means by which the animal is connected to the tool so that work may be accomplished. In some regions, the harness is used principally as a means of animal control, and energy transmission is secondary. In other regions, the harness is principally for energy transmission, while control of the bullock is accomplished by good training, well-fitted yokes, traces, and verbal commands.

In general, pairs of oxen are yoked side by side by either of two devices: the double head yoke (Fig. 1.4) or the double shoulder yoke (Fig. 1.5).

There is some disagreement as to the nomenclature of these two types of yokes. Some call a head yoke a neck yoke while others refer to shoulder yokes as neck yokes or withers yokes. The terms head yoke and shoulder yoke are used here, since they are the most descriptive.

The double head yoke is suitable only for strong, short-necked bullocks. The yoke is fixed at the front or back of the head and held rigidly by thongs that bind the yoke to the bullocks' horns.

The double head yoke fixed to the back of the head is used in Spain and Latin America. Because it is tied to the horns, the yoke must be shaped and fitted to the individual bullocks. Since the yoke is not fastened to the animals' necks, there is no problem with chafing caused by ill-fitting neck yokes. The double head yoke, when securely fastened to the horns, provides the means by which the bullocks can pull, push, or brake the vehicle or tool being drawn. Should the implement

1.4. Double head yoke.



1.5. Double shoulder yoke.

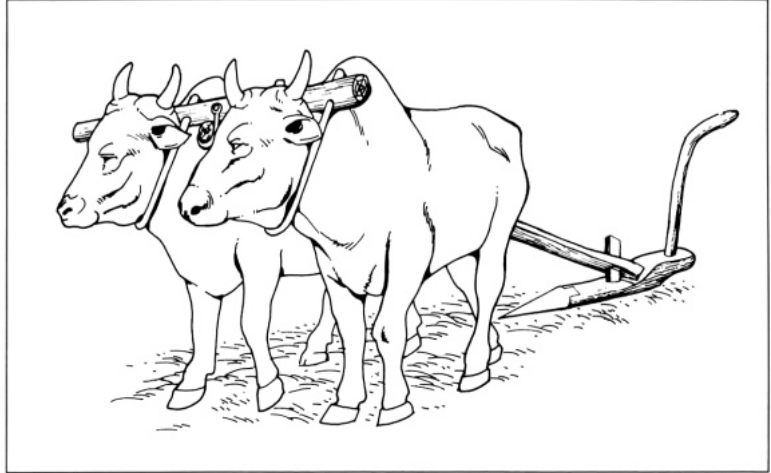

strike an obstacle, however, the bullock can be injured unless there is a device between the yoke and the implement to absorb shock.

The double head yoke was not designed for the comfort of oxen. They are unable to shake their heads when flies annoy them. In fact, they cannot move their heads at all except in unison.

The double shoulder yoke is common in Africa, the Near East, India, and the Mediterranean. It was also the type used by North American pioneers. In some countries of the Near East, the double shoulder yoke is also used for donkeys, horses, and mules. Pads and collars are required when the yoke is fitted to these animals.

The double shoulder yoke used in North America is a wooden beam 1.2-2 m long and shaped to fit the top of the oxen's necks in the shoulder region. In Africa, the yoke consists of a pole with fleece shoulder padding. The yoke is prevented from moving transversely by chains, rope, steel or wooden U-pins, or by vertical pins on each side of the neck. The lag pole (tongue) of the implement is attached to a steel ring or notch in the center of the yoke. If the yoke slips rearward, the fasteners tend to choke the animal.

Unlike the double head yoke, the double shoulder yoke permits the bullock freedom of movement. In addition, it allows the line of draft to be applied lower to the ground and more in line with the backbone of the bullock. Other advantages are that it does not require a pair of bullocks of

18 HUMAN AND ANIMAL POWER

identical size; it can be fitted to hornless bullocks; and it is simple to shape and easy to fabricate

The double shoulder yoke has disadvantages as well, however. The primary disadvantage is that it can compress the windpipe and blood vessels in the bullock's chest. Sores are apt to be more frequent, especially around the shoulder blades. Also, the yoke has a tendency to slip rearward because of the line of draft. Many people consider this yoke more difficult for driving bullocks, but I believe driving control results from training rather than the type of yoke.

Implements or vehicles are hitched by long poles or ropes to the center of the double yoke. The team is usually directed by the farmer using a long pole or whip in combination with verbal commands. In some regions a nose rope used as a jerk line is used to indicate commands. In societies where work animals are not well trained or are provided with insufficient food and care, it is sometimes necessary for one person to lead the team while another operates the plow or implement.

Bullocks are usually harnessed in pairs for heavy work; but for lighter work, a single animal is often sufficient. A single head yoke, a simple shoulder yoke, or a collar can be used to harness a single bullock. Instead of connecting the implement or vehicle to the bullock with a single heavy pole, pairs of wooden shafts, ropes, or leather traces with a singletree are employed.

The single shoulder yoke (Fig. 1.6) is used in Southeast Asia, China, and some European countries. The singletree (also called swingletree, whiffletree, or whippetree) is essential when hitching a single animal to an implement. Traces

1.6. Single shoulder yoke.

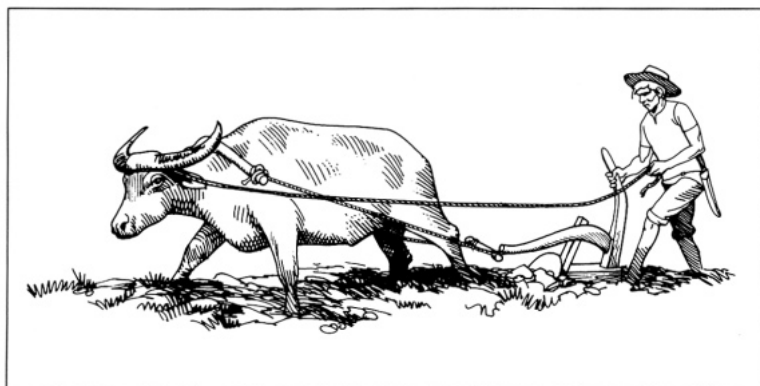

19 DIBBLE STICKS, DONKEYS, AND DIESELS

connect the singletree to the shoulder yoke. The singletree provides rotational movement between the implement and the draft animal. Single head yokes are used in some areas of Europe. The traces connect the singletree to the outboard ends of the head yoke.

A collar harness is occasionally seen on a bullock, but since collars are more expensive than traditional yokes and have little advantage other than comfort, they are rarely used in LDCs.

An improvement is the padded shoulder harness (Fig. 1.7), which provides the advantage of a collar harness at lower cost. The traces are pulled tight only while the animal is pulling. Unless the traces are used in combination with a wide single yoke, it is necessary to use a surcingle to support the traces when not under tension; otherwise they will hang down and trip the animal. The surcingle is usually a length of leather or webbing about 8 cm wide with a ring or loop on each end. It fits over the bullock's back, and a trace passes through each ring. The surcingle should be adjusted so that, when the traces are tight, a straight line exists between the

1.7. Improved shoulder harness for an ox.

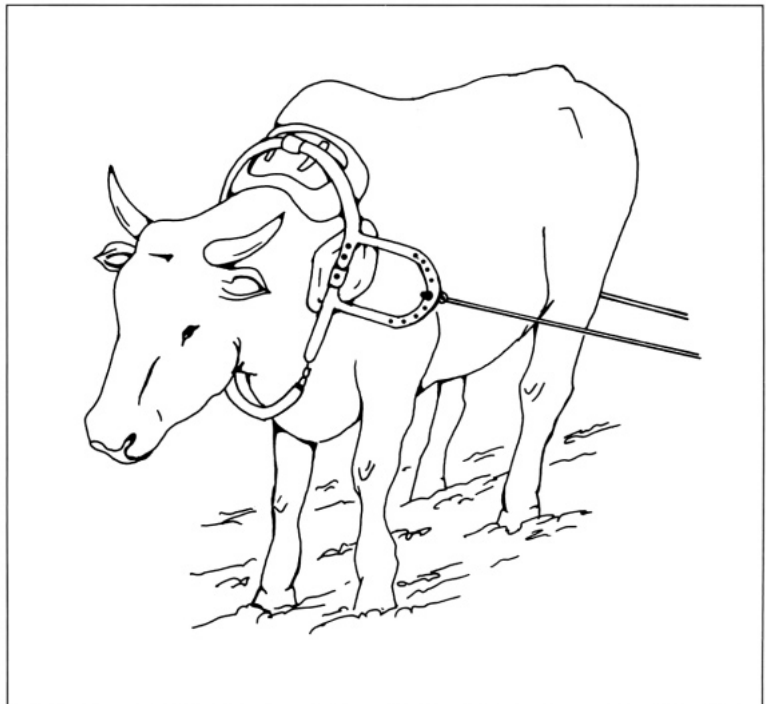

point where the traces pass through the surcingle ring and the trace attachment points on the yoke and the singletree.

Individual bullocks may be harnessed to pull a single load with single yokes connected by joining the singletrees. The center fastening ring of each singletree is fastened to the opposite ends of a wooden piece called a doubletree. If more than two oxen are to be hitched parallel, the singletrees are attached to an eveners.

Double yokes of oxen are often hitched together. For example, six oxen may be hitched to a load by placing three pairs of oxen in tandem.

Oxen exert draft by friction between their hooves and the ground. If oxen are to be used extensively on hard pavement, they should be fitted with shoes. Since bovines have cloven hooves, they cannot be shod with a one-piece shoe like horses. To shoe oxen, two half-plates must be fitted to each hoof.

A balanced diet and sufficient calorie consumption are as important for draft animals as they are for people. It is surprising, however, that many farmers believe that bullocks can sustain themselves solely on forage. On the contrary, draft animals must be fed grain to supplement their forage.

The ration a bullock receives depends on its age, its feed, and the work. The following five daily rations are typical for feeding draft bullocks in India.

- For a 375-kg bullock working an 8-h day:
 - 4.5 kg rice straw
 - 9.0 kg green sorghum
 - 1.0 kg mustard (*Brassica, juncea*) or 7.0 kg sorghum straw
 - 0.5 kg rape (*Brassica napus*)
- For the same bullock as above:
 - if the bullock grazes at least 7 h/d and rests in the shade when not working, it consumes approximately 25 kg mixed pasture grass, which supplies sufficient energy and protein.
- For a 450-kg bullock plowing 6 h/d in the hot season:
 - 2.5 kg wheat bhusa (wheat straw chopped into 1-cm pieces)
 - 11 kg jowar (*Andropogon sorghum vulgare*) and quara (*Cyamopsis psoraloides*)
 - 2 kg gram (*Phaseolus*)

- Normal working ration:
4 kg of fodder/0.45 kg body weight
0.5 kg grain/h of work with a daily maximum of 4 kg
- Nonworking days ration:
4 kg of fodder 0.45 kg body weight¹⁵

Most Indian bullocks are fed less than recommended. Typically, they are fed 15 kg fodder and 1 kg grain daily.

A bullock should have access to about 30 liters (8 U.S. gal) of water per day. It should be watered twice during each work period. Twice daily is sufficient during the idle season. The feeding and care of a bullock are related to its work output. Large, well-fed bullocks of the Haryana breed provided 8.6 hp-h of work over a 9-h day, while smaller, poorly fed bullocks provided only one-fourth that amount.¹⁶

1.3.2 Water buffalo. The water buffalo (*Bubalus bubalis*) is usually associated with rice production in Asia, but is also used in Egypt, the Soviet Union, Bulgaria, and Italy. Approximately 200,000 exist in Brazil, where they are raised as a source of meat rather than power. More than 126 million water buffalo exist worldwide. The large, fierce African buffalo (*Syncerus caffer*) should not be confused with the more common and useful water buffalo.

The water buffalo is important to tropical agriculture because it is a gentle, domesticated animal that provides power as well as milk and meat, while subsisting on fodder. It does well in hot, humid climates, and its bulky body, large feet and slow, steady pace make it particularly useful in flooded ricefield. Water buffalo can be divided into two major groups: swamp buffalo and river buffalo.

The swamp buffalo is found in the Philippines (where it is called the carabao and other Southeast Asian countries). It has an ox-like appearance and is gray to slate in color. It is distinguished by its large, swept-back horns and a white band across the neck slightly anterior to the brisket.

The river buffalo is more common in India, Egypt, and eastern Europe. It is usually black and resembles a large milk cow but is distinguished by its coiled horns. The horn is triangular in cross section from the basal to the middle portion. River buffalo are better milk producers than swamp buffalo. In India, there are half a dozen well defined breeds of river buffalo.

Although the water buffalo is related to the domestic cow and the American bison, it is not possible to crossbreed them. Buffalo have 48 chromosomes, while domestic cattle and bison have 60. The water buffalo's ability to regulate body temperature is inferior to that of tropical cattle. The buffalo has few sweat glands, and its hair is sparse and coarse. It requires protection from both intense sun and cool winter winds. Water buffalo enjoy submerging in water or wallowing in mud during the heat of the day. If arrangements are not made for the buffalo to have access to a stream or water spray during the hot season, its health deteriorates rapidly.

The buffalo compares favorably to the bullock in certain respects, but unfavorable in others. As a draft animal on a road, the water buffalo is inferior to the bullock. The buffalo cannot withstand dry heat and direct sun as well as oxen, and its feet are not as tough. Early castration of males intended for work not only makes them docile, but results in a neck conformation that facilitates fitting the yoke. In this regard, water buffalo are more convenient than bullocks, which do not have a neck well suited for the yoke if they are castrated too early.

The same type of harness is used with both the water buffalo and the bullock. Whereas bullocks are most commonly harnessed in pairs, water buffalo usually work singly with the single shoulder yoke.

Tests were conducted in the Philippines using six 500-kg male carabao. Pulling loads on grass for 2-h periods, each carabao provided draft power of 0.5-1.3 hp. The animals' speed of 3.5 km/h remained constant over the test periods under draft test loads of 40, 60, and 100 kg (88, 132, 220 lb; or 392, 588, 980 N). The highest power output occurred while pulling the 100-kg draft load. At the end of the 2-h, 100-kg draft load tests, the animals' body temperatures were elevated and they required a rest.¹⁷

The water buffalo usually maintains itself by grazing. Lactating animals are sometimes provided with grain or oil meal cake.

Water buffalo are subject to the same diseases as cattle: foot and mouth disease, rinderpest, haemorrhagic septicaemia, and anthrax. They frequently host the larger cattle parasites but exhibit little evidence of their presence. The productive life of a water buffalo is approximately 6 yr.

1.3.3 Elephants. The elephant is the largest domesticated draft animal. An adult elephant weighs approximately 3 t. Because of their great weight, elephants have a stiff-legged walk, which for a working elephant varies from 3.4 to 3.7 km/h (2.1-2.3 mph).¹⁸ As a prime mover, the elephant has a barely adequate cooling system. Because of its smaller ratio of surface to bulk compared with other animals, the elephant is not able to dissipate heat well. In tropical climates the elephant is usually worked only 3 h in the morning and 3 h in late afternoon to avoid the hottest part of the day.¹⁹

Research on using elephants for tillage was conducted at the Neelgaon Farm near Sidhauli in Uttar Pradesh, India. Using a special elephant harness and pulling a two-bottom moldboard plow, an elephant easily plowed 1 ha of land 15 cm deep in 4 h. Another animal turned over 2 ha in 4 h with a disc harrow.²⁰ Elephants can provide draft power of 4-5 hp and can lift approximately 700 kg. As a beast of burden the elephant can carry approximately 500 kg. The active life of an elephant is about 60 yr, but the best work years are between the ages of 20 and 40. Unfortunately, an elephant needs a large supply of fodder and thus is inexpensive to use only where fodder is inexpensive. An elephant requires approximately 125 kg of fresh material and 50 kg of dry material per day. The Indian army ration for medium-sized elephants consists of 6.8 kg grain, 80 kg dry fodder, 180 kg green fodder, 56 g salt, and 28 g of oil, plus about 200 liters (50 US gal) of fresh water per day.²¹

Indian elephants are used for transport and log handling. Although African elephants are not domesticated, in 1925 and again in the 1950s. African forest elephants (*Loxodonta africana cyclotis*) were trained for work in the Belgian Congo (now Zaire).²² Unfortunately, the elephants and their trainers disappeared during the civil war in the early 1960s.²³

1.3.4 Horses. The horse (*Equus caballus*) used for draft is usually broad and massive. It has a thick neck, heavily muscled shoulders and legs, a wide chest, and coarse legs. In Europe and North America, horses used for farming are of larger breeds and are better fed than those in LDCs. Farm horses range from 350 to 1,000 kg in weight and 150 to 175 cm in height. The height of a horse is the vertical distance from the ground to the withers. The withers is the ridge between

24 HUMAN AND ANIMAL POWER

the horse's shoulder bones (Fig. 1.8). A linear measurement equal to four inches (10 cm) and called a hand is used to express the height of a horse in English-speaking countries; farm horses range from 15 to 17 hands in height.

Horses are usually put to work when 2-3 yr old and can continue to work until about age 20. Mares, stallions, and geldings (castrated males) are all useful as draft animals. Geldings are quieter and easier to handle than stallions. Colts are usually castrated as yearlings or 2-yr-olds.

Draft horses are not well adapted to the hot humid tropics, since the ratio of body mass to surface area limits cooling even though horses utilize sweating to cool themselves. Horses are used in the tropical highlands, which are cooler than the lowlands. However, above 3,000 m (10,000 ft) altitude, horses develop enlarged hearts and other problems because of the thin air.

Working horses are fed and watered three times a day. One-fourth of the horse's daily feed is given at least 1 h before work. At midday, after about 5h of work, the horse is watered and fed another fourth of its daily ration. When the horse is stabled after the afternoon's work, it is watered and fed half its daily ration. The horse should be watered before and after each meal. The type and amount of feed a horse requires depend on the work. Horses should be provided with 2.2 kg

1.8. Nomenclature of a horse.

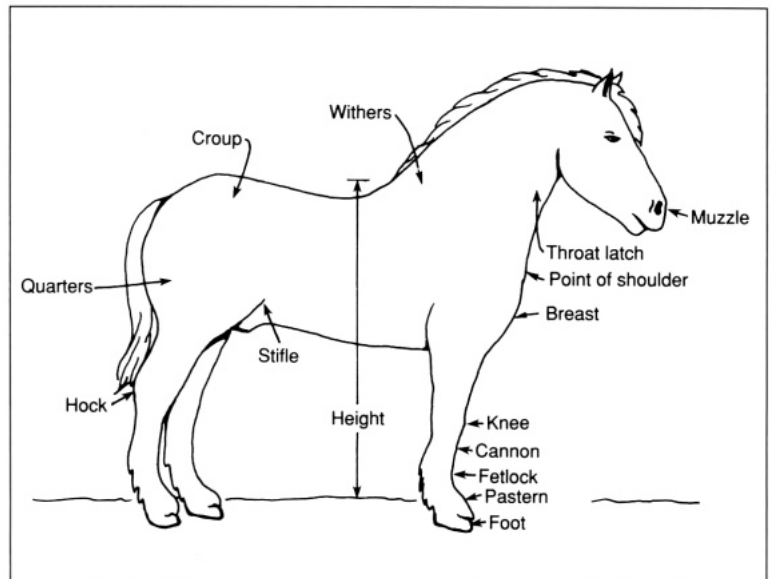

25 DIBBLE STICKS, DONKEYS, AND DIESELS

of feedstuff for every 100 kg of body weight (2.2 lb/100 lb body weight); 1 kg grain and 1.2 kg hay/100 kg is ample for ordinary farm work. Maize, oats, and barley are the grains most commonly fed to horses. Barley should be crushed. Hay should be of good quality and, if possible, alfalfa hay should constitute one-third to one-half of the ration. A 650-kg horse or mule requires 6.5 kg grain and 7.8 kg hay per day. If horses are turned out to a good mixed pasture during rest time, they will eat about 50% less hay.

The daily feed requirements of draft horses can be expressed in terms of total digestible nutrients (TDN) by the following equation:

$$\text{TDN} = 0.043 W^{0.73} + 0.215 H$$

where: TDN = kg,
W = body weight in kg, and
H = work output in MJ

In English units, the equation is:

$$\text{TDN} = 0.053 W^{0.73} + 1.27H$$

where: TDN = lb,
W = body weight in lb,
H = work output in hp-h²⁴

The first term represents maintenance requirements, while the second term represents energy for work output. For example, a 500-kg (1100 lb,) horse with a work output of 13 MJ/d requires 6.8 kg (15.0 lb) of TDN per day. These estimates are in general agreement with the values provided by Goe and McDowell.

Horses, mules, and donkeys have well-developed shoulders and chests, but weak withers. Collar harnesses or breastband harness are therefore used. Collar harnesses are required for heavy draft work such as plowing, while breastband harnesses are satisfactory for light work such as pulling a light buggy. The several types of harnesses for horses, mules, and donkeys vary according to the implement or vehicle, the training of the animal, the number of animals hitched together, and the owner's idiosyncrasies. Harnesses are usually made of leather. If properly fitted and maintained, a good harness can be serviceable for 20 yr.

The following description of harnessing a horse also applies to mules and donkeys. Harnesses are illustrated for

three situations: single horse with breastband harness (Fig. 1.9, 1.10) and 2-, 5-, and 10-horse teams with collar harnesses (Fig. 1.12, 1.14, 1.15).

The breastband harness places the load against the horse's breast by means of a wide leather strap called the breastband or breast collar. The traces connect to the implement. Traces are made from either leather or steel chain. The bridle is the headgear used to govern the horse. It consists of the bit, noseband, front, cheekpiece, and throat latch. The bit is made of steel and is placed in the horse's mouth. The reins are leather straps fastened to the bit on one end and held by the driver on the other. By means of a pull on one or both of the reins—often accompanied by a voice command—the driver controls the horse. The reins are prevented from falling to the ground and becoming entangled in the horse's legs by means of a metal ring called a terret, which is shown fastened to the neckstrap.

Blinders are stiff leather pieces that prevent the horse from seeing sideways and that direct its attention straight ahead. The blinders prevent the horse from becoming aware of movement to the side. When harnessing a horse, the bridle is first slipped over the horse's head, while the bit is placed in the mouth. The throat latch, which is a strap passing under the horse's throat, is then adjusted so that it is snug enough to prevent the horse from pulling off the bridle, but loose

1.9. Simple breastband harness.

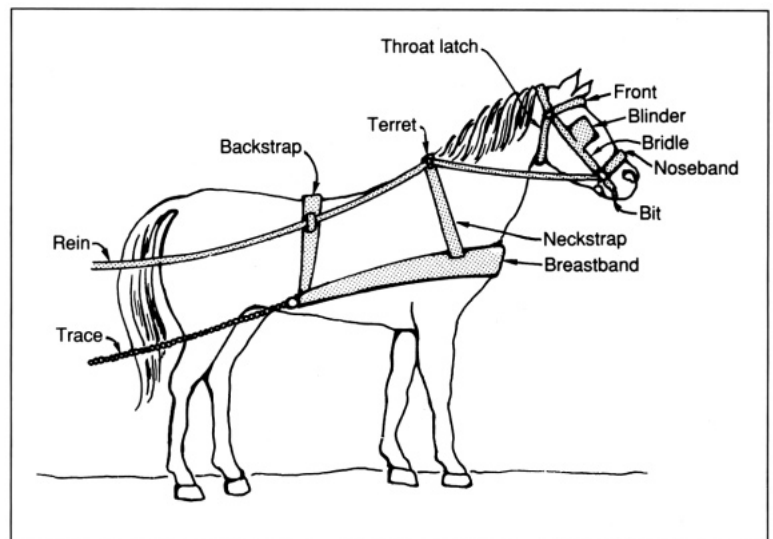

enough so as not to bind and cause discomfort. The backstrap and the neckstrap of the breastband harness support the breastband at the proper height. Just as a suit of clothes or a backpack should be fitted to the human individual, a harness must be fitted to each horse.

The simple breastband harness shown in Figure 1.9 cannot be used to pull a buggy or an implement with a line of draft high enough to lift the harness off the horse's back. A buggy requires an attachment for the shafts and a means to prevent the buggy from pushing the harness forward into the horse when descending a hill.

By placing a bellyband on the simple breastband harness, loads with a higher line of pull can be drawn without lifting the harness off the horse. A buggy can be hitched to the harness illustrated in Figure 1.10 by attaching the shafts (sometimes called thills) to the saddle. A flat leather strap, called breeching, keeps the buggy from running into the horse while descending a hill by preventing the harness from moving forward. The shafts are attached to the saddle, and a strap secures the saddle to the breeching, so that when the buggy pushes on the shafts and the shafts on the saddle, the strap fastened between the saddle and the breeching transfers the load to the breeching, and this to the animal's rump. The crupper goes around the tail to prevent the harness from sliding off the horse.

The check rein is used when the driver wants to prevent the horse from lowering its head to graze.

1.10. Breastband harness with bellyband and breeching.

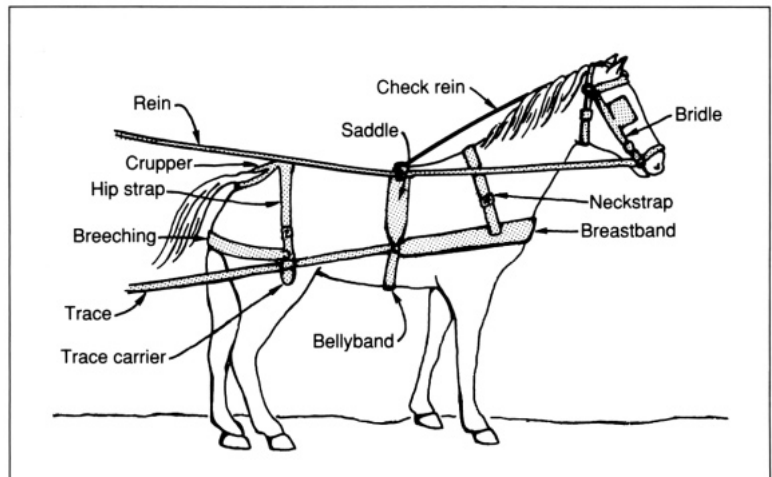

Horses, mules, and donkeys need to use collars for pulling heavy loads (Fig. 1.11). Horse collars are manufactured in specific sizes to assure proper fit. When fitting a collar to a new work animal, different sizes should be tried until one that fits is found. Horse collars come in three types: regular, half sweeney, and full sweeney. The regular is for long, flat, slender necks; the half sweeney is for a neck that is a bit heavier and slightly thick at top; and the full sweeney is for a neck very thick at the top. The size of a collar is determined by its inside length measured from top to bottom. For example, a size 20 collar measures 20 inches (50.8 cm) from top to bottom just inside the rim. Small draft horses require size 16 or smaller, while very large draft horses need size 24 or larger.²⁶ Collars are sometimes further characterized by a measurement of the cross-section circumference at the collar's widest point. This measurement is called the draft size.

To fit a collar, the horse is moved forward against a load until the collar is firmly against its shoulders. Alternately, a strong person can pull back on the traces. Correctly fitted, the collar should allow only sufficient space between the sides of the neck to pass the flat of the hand.

When the collar is forced back, there should be about 5-cm clearance between the collar and the animal's throat. A short collar causes a sore neck, chokes the horse by pressing

1.11. Horse collar.

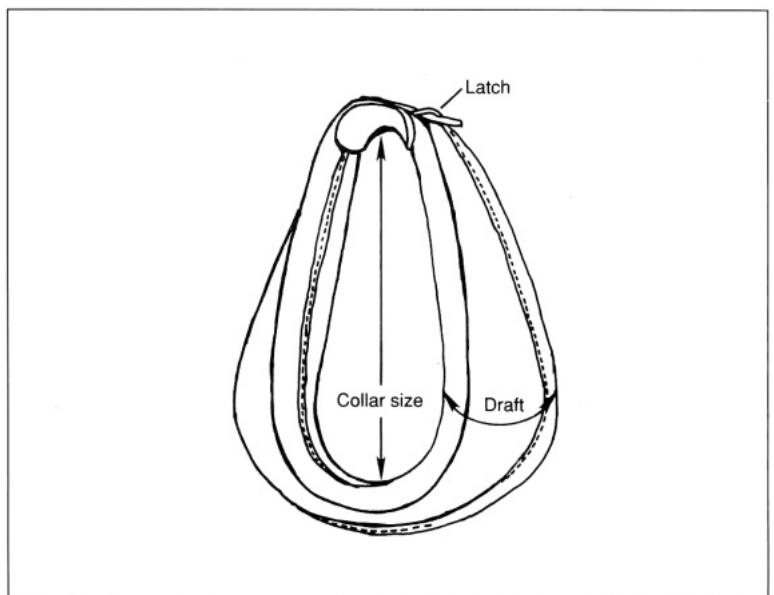

against the windpipe, and sets the point of draft too high. A long collar places the point of draft too low and causes shoulder sores. Once a collar is fitted, it should not be taken apart each time the horse is harnessed. Instead, the collar should be kept buckled and slipped over the horse's head during harnessing.

Collars fitted prior to heavy work often become too large—especially too wide—as the horse becomes thinner from hard work. If this occurs, a collar pad of quilted cotton should be inserted to improve the fit.

The traces are not attached directly to the collar, but to a separate steel or steel reinforced rib called a hame. A hame fits on each side of the collar, and the pair of hames are tightly strapped, top and bottom, to the outside groove of the collar. The hame consists of three rings and a metal bolt. The trace attaches to the bolt, the breast strap to the bottom ring, and the hack strap to the second ring. The rein passes through the top ring. An ornamental metal ball is usually attached to the top of the hame.

Figure 1.12 depicts a harness for a typical team of two horses or mules. The two-animal team is the most common draft configuration. Note that the wagon or implement is pulled forward by the interaction of various connecting parts.

1.12. Harness for a team of two draft horses.

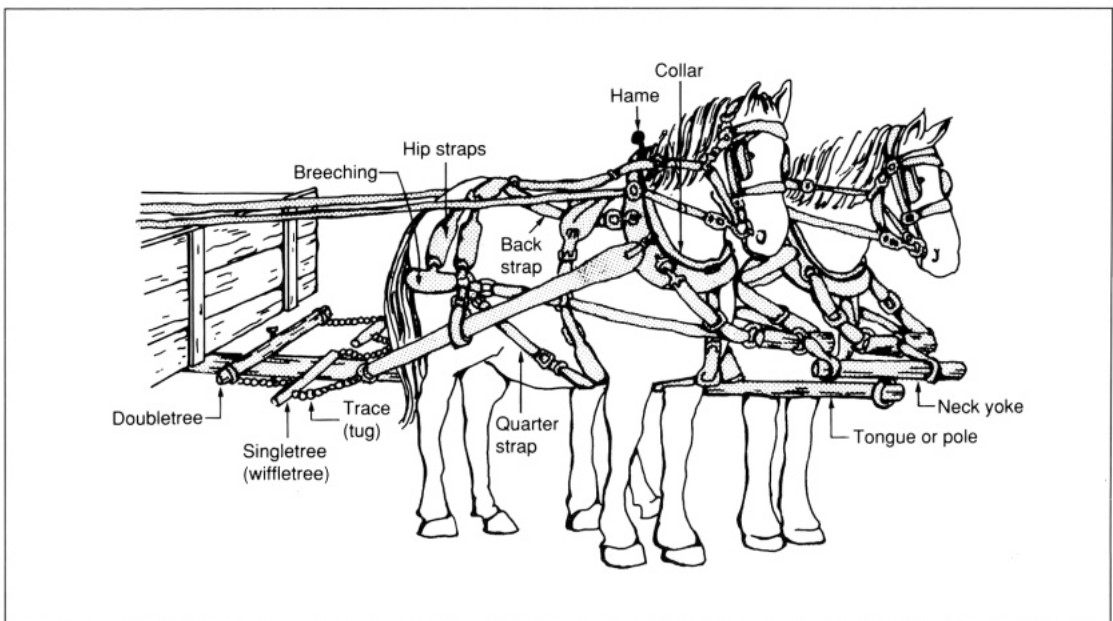

First, the animal pushes against the collar, to which the hames are attached. Second, the traces, which are attached to the hames, transmit the pull to the singletrees. Third, the pull is transferred from the singletrees to the doubletree, which is attached to the wagon tongue.

When the team must hold back a wagon while descending a hill, the force is transmitted in reverse, since the wagon pushes the tongue forward. First, the tongue transmits the forward force to the neck yoke. Second, the force moves from the neck yoke to the jockey yokes. Third, the jockey yokes transfer the force to the harness, which moves forward until the breeching moves into contact with the animal's rear quarters.

When driving a team, the reins are attached to the outside of the animals, and cross check lines are crossed between the animals to provide maximum control. The cross check lines (Fig. 1.13) enable one rein to turn both animals.

When greater horsepower is required, horses and mules can be hitched in larger teams. In constructing hitches for multi-horse teams, it is important that the geometry, of the

1.13. Team and cross check reins.

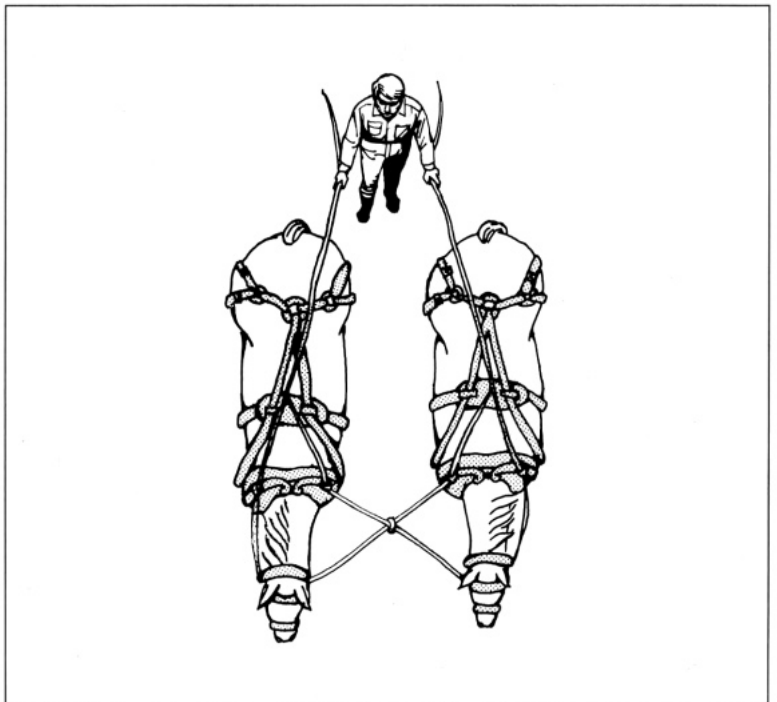

hitch be such that 1) the load is equalized so that no animal can loaf, 2) side draft is minimized, and 3) each animal has as much space and comfort as possible.²⁷ A typical 5-horse hitch is illustrated in Figure 1.14. In this configuration, the rear team has sufficient air space and the driver has a good view of all the horses. There is also plenty of room for lines and less opportunity for crowding and trampling during sharp turns.

The 10-horse hitch shown in Figure 1.15 has an advantage in that the driver needs to control only the two lead horses. Since the lead team sets the pace, they should be well matched.

Eveners are made of steel-reinforced wood 5-10 cm thick and about 1 m long. In a multi-horse hitch, the singletrees and doubletrees attach to the eveners. These attach to other

1.14. Five-horse team (left).

1.15. Ten-horse team (right).

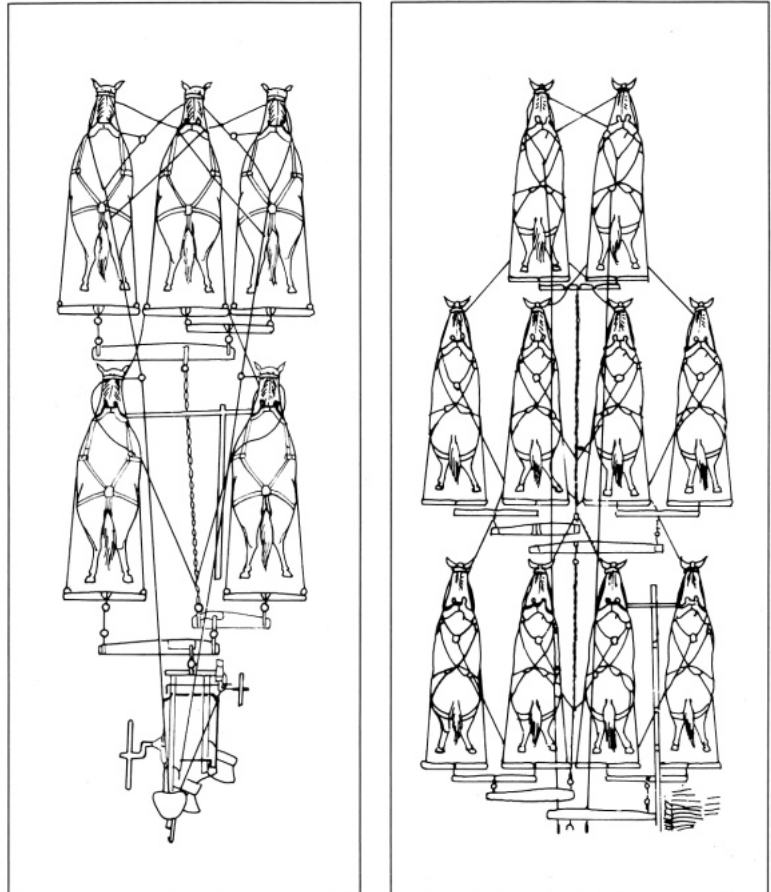

eveners and eventually to the implement. The purpose of the evener is to balance the forces. For example, the 5-horse team in Figure 1.14 has the forward right and center horses hitched so that their combined pull is exerted through a doubletree attached to one end of an evener. The left front horse is attached to the same evener. Since the left front horse can pull only half as much as the other two, its singletree attachment to the evener is twice as far from the draft chain on the evener as is the doubletree from the other two horses (80 cm as opposed to 40 cm).

To guide the horse, the farmer uses a pair of reins fastened to a bit in the horse's mouth as well as verbal commands. In North America, common terms are "whoa" to stop, "steady" to move more slowly, "gitty-up" to begin moving forward, "gee" to turn to the off-side or right, and "haw" to turn to the near-side or left.

If the horse is working on soft ground, horseshoes are not necessary. But if the horse is to be driven on hard roads or slippery streets, it should be shod. The blacksmith must custom-fit each shoe. For ordinary conditions, a plain shoe without calks and sufficiently heavy to carry the animal's weight should be used. Shoes should be reset every 6 wk. If possible, horses that are kept shod most of the year should have their shoes removed for 1 mo and be allowed to work on soft ground in order to allow the hoof to recover its natural condition.

1.3.5 *Mules*. A mule is the general term for the offspring of a horse and a donkey. Actually, the offspring of a mare and a jackass is called a mule, while the offspring of a stallion and a jennet is called a hinny. The mule is more valuable, since it is larger than the hinny.

The mule is preferable to the horse as a work animal because it is less afflicted by disease and can utilize inferior feedstuffs. However, it is more discriminating of certain feeds than the horse. Mules are often chosen over horses for hot, humid climates, or for terrain requiring steadiness and sure-footedness.

Mules weigh 300-600 kg (650-1300 lb) and are of various colors. In height they vary from 150 to 175 cm. Mules are harnessed in the same manner as horses. It is not uncommon to hitch horses and mules together as a team.

Mules are usually put to work at 3-4 yr of age, but they are at their peak at 6-10 yr. The mule has a long life. Some have lived to be 70 yr old

If a mammal's lifetime is measured by the number of heartbeats, all have approximately the same life span of 800 million heartbeats and 100 million breaths. The cow and elephant have the same number of heartbeats per lifetime as all other mammals. The exception is man, who has three times as many heartbeats per lifetime as other mammals.²⁸

1.3.6 Donkeys. The donkey is also known as the domestic ass (*Equus asinus*). The small ass or burro is also known in some regions as a donkey. The donkey is primarily a pack animal, and can travel about 30 km/d, but it is also used in some regions as a draft animal. Like horses and mules, donkeys must be shod. Males are called jacks or jackasses, while females are called jennets. Donkeys range in height from about one meter to the size of small horses. The ass is noted for its endurance, surefootedness, docility, and ability to subsist on feedstuffs inferior to those required by horses. As pack animals, asses carry from 50 to 135 kg (110-300 lb) over distances of 25 to 32 km (15-20 mi) per day.

1.3.7 Camels. Camels are used primarily as pack animals—"baggers"—but are also employed for riding and for draft. There are two species of camels. The Arabian camel (*Camelus dromedarius*) has one hump and thrives in the tropics, while the Bactrian camel of Asia (*Camelus bactrianus*) has two humps and can live in cold climates. The single-humped Arabian camel is the animal discussed here.

Riding, baggage, and draft camels differ in body conformation and qualities, just as saddle horses differ from work horses. The riding camel is an efficient means of communication in remote areas. A riding camel should be slender and long-legged, with a strong but fine bone structure. A thin, supple skin and a drooping rump of medium length are characteristic of a riding camel. The baggage camel should be robust, heavy, and well furnished with bone and muscle. The hump should be well developed. Legs should be heavy, and the hooves should be large and flat. The draft camel has the same qualities as the baggage camel, since it is used for its brute strength and ability to work on sandy or loose soil. Draft

camels are used singly or in pairs, and are sometimes yoked with bullocks or donkeys.²⁹ Figure 1.16 illustrates a camel plowing.

Most animals regulate body temperature by a metabolic activity that keeps body temperature nearly constant even when they are engaged in physical activity. An increase in physical activity produces excess heat, which must be dumped to maintain body temperature. Excess heat is dumped through evaporative cooling by panting or sweating. Evaporation is an effective means of cooling, particularly under low humidity, but the process consumes body moisture.

The camel is one of the few large mammals (the giraffe is another) that allows body temperature to fluctuate 3-10°C during the day. Passive heating and cooling conserve a large amount of water.³⁰ The camel's regulation of body temperature is analogous to the regulation of house temperature during summer in the temperate zone. For example, the desired house temperature may be 25°C. Rather than turning on the furnace during the cool early morning, the house is allowed to heat slowly by passive heating from rising outside air temperature as the sun rises in the sky. If the house

1.16. Camel plowing.

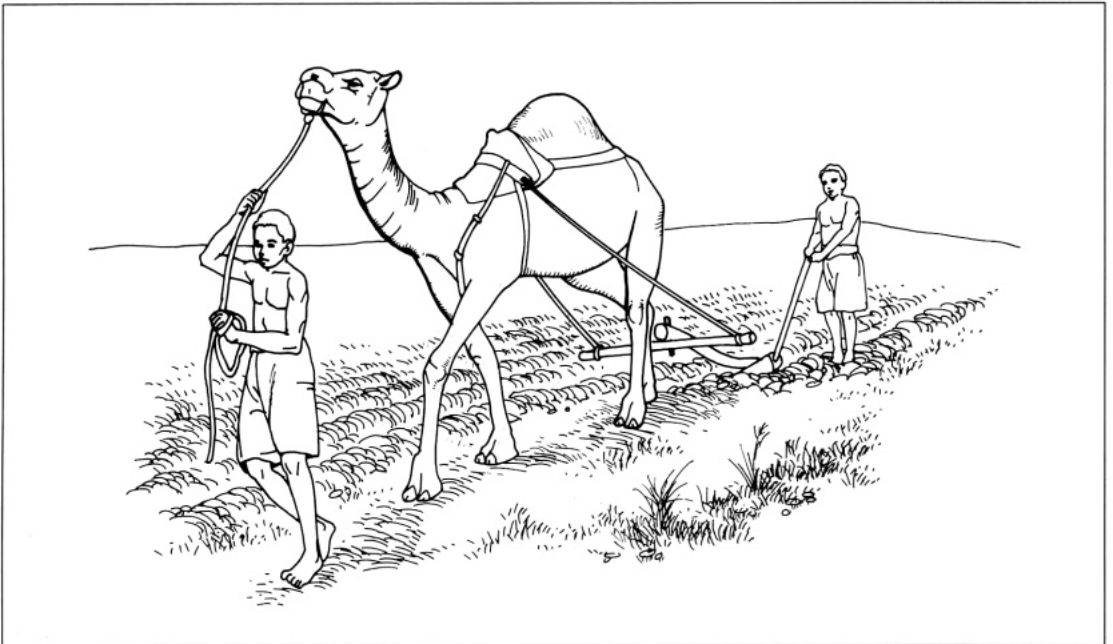

temperature rises above the desired 25°C, it may be necessary to dump excess heat from the house by turning on an air conditioner. Had the house been heated to 25°C in early morning and the temperature kept constant, it would have been necessary to turn on the air conditioner before noon—analogueous to sweating or panting in an animal to dump excess heat.

Prior to the American Civil War, camels were used for transport in the southwestern United States. The U.S. Army imported 74 Arabian camels between 1856 and 1857. These animals were used primarily in Texas, New Mexico, and California. In 1861, a private company imported 20 Bactrian camels from Central Asia. These animals were used to transport salt in Nevada.

Camels are ruminants. They often prefer to eat shoots or twigs rather than grass. A general rule is that camels should be allowed at least 6 h/d for foraging, and another 6 h for rumination. Where conditions do not permit foraging, camels can be fed the same feedstuff as that fed to cattle. Table 1.3 lists daily rations for baggage camels.

The camel is noted for its ability to endure long periods without water. Whenever possible, however, it should be watered daily. A camel drinks up to 35 liters daily. A camel deprived of water for a long time may drink up to 90 liters (24 US gal) of water at one time! Males, females, and castrated males are used for draft work. The castrated male is preferable if castration does not occur before the animal reaches full size at 4-6 yr.

Camels used on the plains are usually long-legged and rangy, and may attain 2.12 m height at the withers. Camels used in rough and hilly areas are smaller, heavy-boned and

Table 1.3. Rations for camels.³¹

Camel type	Grazing condition	Supplementation
Walking camel	Good	No grain, but some salt
Trotting camel	Good	10 lb (4.5 kg) grain each watering day, some salt
Working baggager	Fair	20 lb (9 kg) straw, 4 lb (1.8 kg) gram, some salt
Working baggager	Poor	30 lb (13.5 kg) straw, 6 lb (2.7 kg) gram, some salt

only 1.75-2 m high. Baggage camels can carry 150-300 kg at a speed of 4 km/h for 24 km/d.

The camel can plow at a speed of about 2.5 km/h but is usually worked no longer than 6 h/d—4 h in the morning and 2 h in the afternoon. The rate at which a camel can plow has been reported variously as 11-20 h/ha when plowing to a depth of 16 cm (6.3 in).³² The difference is probably due to soil variance, plowing depth, type of plow, method of hitching, condition of the camel, and skill of the operator.

A saddle is used for pulling a cart and quite often for plowing. The saddle consists of a wooden frame with pads that rest on either side of the animal's backbone. Arches clearing the backbone and on each side of the hump are fastened to the padded vertical frame. A single girth holds the saddle in position. The shafts attach to the sides of the saddle for pulling a cart.

A belly yoke is used for plowing. If the yoke were placed on top of the saddle, the camel's height would place the line of draft at too steep an angle. A padded single yoke in front of the hump is often used instead of a saddle. Alternately, long traces can be attached to the padded single yoke in front of the hump. The length of the traces is such that the plow point may be up to 5 m behind the camel. This extraordinary trace length is necessary to obtain a proper line of draft.

Plowing with a camel usually requires two people—one to lead the camel and one to handle the plow. The camel is controlled by a nose peg and head rope.

Camels can be put to heavy work from about 6 to 20 yr of age. If properly managed, camels may live up to 45 yr.

1.3.8 Llamas. The llama (*Lama glama*) and the alpaca (*Lama pacos*) are American relatives of the camel. They are raised and used in the Andean countries at high altitudes (2,600-4,600 m; 8,000-14,000 ft).

The llama is raised for wool, meat, and use as a pack animal (Fig. 1.17). The alpaca is smaller than the llama and is raised chiefly for its wool. It is seldom used as a pack animal, since it cannot carry as much as a llama. Llamas reach maturity at about 2 yr and weigh 85-120 kg.

Only males 3-7 yr old are used as pack animals. Castrated males of 4-6 yr are preferred. The average mature male llama can carry 35-45 kg (75-100 lb) over short distances. On

1.17. Pack llama.

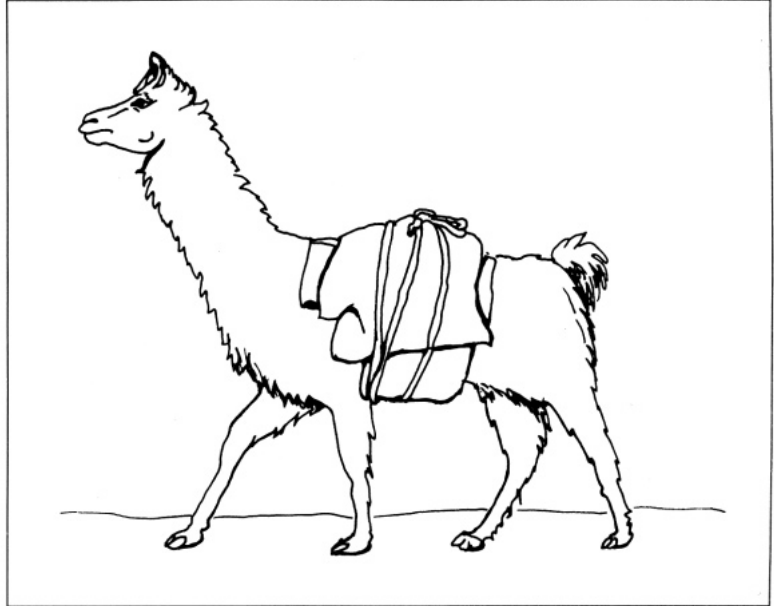

caravan treks, however, drovers limit loads to about 25 kg (55 lb) to reduce fatigue.

Cargo carried by llamas is usually grain, potatoes, or salt. Bags are half-filled with cargo and draped across the llama's back. A rope secures the bag to the llama. The top of a llama's back is about 1.2 m high, so llamas are loaded while standing, unlike camels. Although a good pack llama can travel 40 km/d over a period of 3-4 wk, a typical llama caravan traveling 6 h/d between morning and late afternoon grazing will cover about 300 km in 22 d, including 7 rest days.³³ This is an average of 20 km/d over arid plateau, mountain trails, and high valleys.

1.4 Rotary power from animals

Animals are best suited for work by pulling. To operate machines such as irrigation pumps, threshers, and grinding mills, however, rotary power is required. Sweep powers and tread mills are devices that can convert animal power to rotary power.

Sweep power (sometimes called circular horsepower, power-gear, or a horse-gin) is used in many countries to power pumps, threshers, and sugarcane presses (Fig. 1.18). Many sweep power machines are wasteful of the draft animal's energy, since the units utilize roughly cut gears and

1.18. Horse with sweep made from automotive axle and differential.

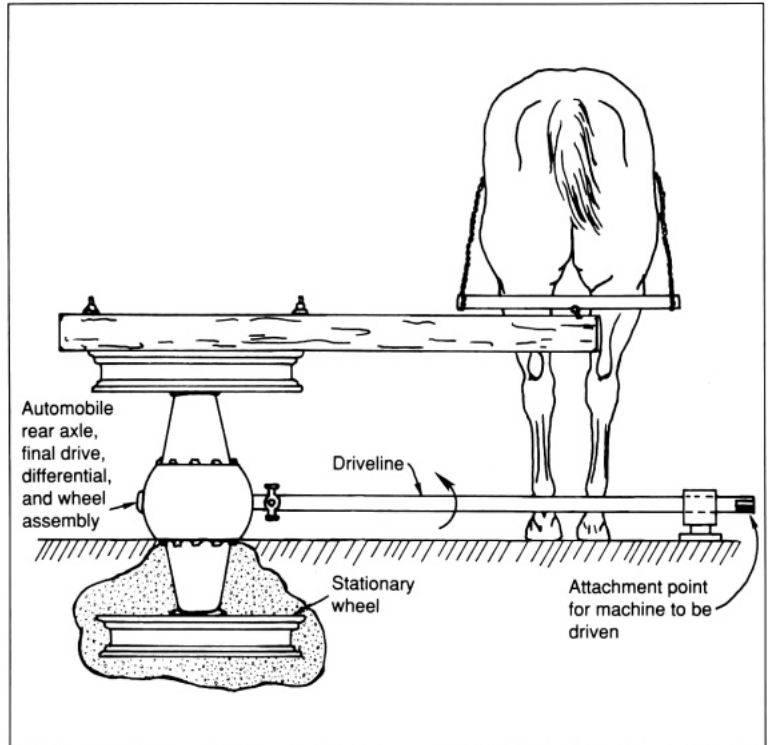

poorly lubricated high-friction bearings. Manufactured units are more efficient because of machined gears and pinions, and proper lubrication.

Treadmills are made in sizes ranging from those powered by a dog to those requiring several oxen or horses. A treadmill consists of a slatted floor or belt that is inclined and mounted on bearings. The animal walks forward and lifts its weight against the force of gravity. The floor of the treadmill should have a pitch of one vertical unit for each four horizontal units. Thus, the animal constantly lifts one-fourth its weight. The faster the animal walks, the greater the power output. Because of the number of bearings and sliding surfaces in these machines, it is imperative that they be well lubricated.

REFERENCES CITED

1. Baumeister T. ed (1987) Marks' standard handbook for mechanical engineers. 7th ed. McGraw-Hill Book Co., New York. p 9-209, 210.
2. Food and Agriculture Organization of the United Nations (1985) FAO production yearbook. Vol. 38. FAO Stat. Ser. 61. Rome
3. Food and Agriculture Organization of the United Nations (1972) The employment of draught animals in agriculture. Rome
4. Bailey L H (1908) Cyclopedia of American agriculture. The MacMillan Co., London. p. 217
5. Hopfen H J (1969) Farm Implements for arid and tropical regions. FAO Agric. Dev. Pap 91 Food and Agriculture Organization of the United Nations, Rome. p 10
6. Williamson G, Payne W (1965) An introduction to animal husbandry in the tropics. 2d ed Longmans, Green & Co., London.
7. Van Bath S B H (1963) The agrarian history of Western Europe, AD 500-1850. Edward Arnold Publication, London.
8. Ibid.
9. Marks L S, ed. (1951) Marks' mechanical engineers handbook. 5th ed. McGraw-Hill Book Co.. New York p. 1080.
10. Brody S (1945) Bioenergetic and growth. Reinhold Co., New York.
11. Desowitz R S (1977) The fly that would be king. *Natural History* 86(2): Feb 1977.
12. Juarez F, Duff J B (1977) Changing supply and demand patterns for power tillers in the Philippines. Paper No. 77-03. Philippine Society of Agricultural Engineers, Manila
13. Matthews MDP, Pullen D W N (1975) Cultivation trials with ox-drawn implements using N dama cattle in the Gambia. National Institute of Agricultural Engineering. Silsoe, England.
14. Shiv Chandler Lal Premi (1979) Performance of bullocks under varying conditions of land and climate. Thesis No. AE-79-5 Asian Institute of Technology, Bangkok
15. Williamson and Payne, op. cit.
16. Balis J (1964) A study of farm power units; their performance and cost. Allahabad Agricultural Institute, Allahabad, India.
17. Lantin R M (1984) Energy expenditure and work capacity of the Philippine work carabao while pulling loads. MS thesis, University of the Philippines at Los baños, Laguna, Philippines.
18. Falvey J L (1987) An Introduction to working animals. MPW Australia. Melbourne. p. 162.
19. Ibid., p. 164.
20. Singh SB (1955) The elephant comes into farming. *Indian Farming* 5(2): May 1955.
21. Singh H (1980) Domestic animals. 2d ed. National Book Trust. New Delhi. p. 114-116.

22. Grzimek B (1957) Where Africa's elephants become tame. Pages 136-155 in No room for wild animals. Thames and Hudson Publishing, London.
23. Personal communication from Dr. John King of the International Livestock Center for Africa. Addis Ababa, 11 May, 1982.
24. Brody S, Cunningham R (1936) Comparison between efficiency of horse, man, and motor, with special reference to size and monetary economy. Growth and development. XL Univ. of Missouri Res. Bull. 244. p. 45-50.
25. Goe M F, McDowell RE (1980) Animal traction, guidelines for utilization. Cornell University, Ithaca, New York.
26. Horse and Mule Association of America (no date) Collar, hames and harness fitting. Leaflet 276. Chicago
27. Horse Association of America (1928) Horses, mules, power-profit. Leaflet 190, Chicago.
28. Gould S J (1982) The panda's thumb. W.W. Norton & Co., New York. p. 303-304.
29. Mukasa-Mugerwa E (1981) The camel (*Camelus dromedarius*): a bibliography review. The International Livestock Center for Africa. Addis Ababa. p. 70-79.
30. Langman V A (1982) Giraffe youngsters need a little bit of maternal love. Smithsonian 122(10):102.
31. Mukasa-Mugerwa, op. cit . p 42
32. Ibid., p. 79.
- 53 West TL (1981) Llama caravan of the Andes. Natural History 90(12):62-73.

BIBLIOGRAPHY

- Lampe K J (1982) Animal traction and mechnization. Paper presented at a Seminar on Mechanization of Small Scale Farming, Jun 1982, Hangzhou, People's Republic of China, 30 p.
- Makhijani A, in collaboration with Poole A (1975) Energy and agriculture In the Third World. Ballinger Publishing Co., Cambridge, Massachusetts. 168 p.
- Munzinger P (1982) Animal traction in Africa. German Agency for Technical Cooperation, Eschborn, Federal Republic of Germany. 490 p.
- Singh H (1980) Domestic animals. 2d ed. National Book Trust, New Delhi, India. 156 p.
- Stout B A, Myers C A, Hurand A, Faidley L W (1979) Energy for world agriculture. FAO Agric. Ser 7. Food and Agriculture Organization of the United Nations, Rome.

2 Mechanical power

The word “tractor” derives from the Latin trahere, meaning “to draw.” The first tractors were designed only for draft, but later, devices such as belt pulleys and power-take-off (PTO) shafts were added so that the power unit could furnish rotary power as well as draft power. Tractors can be categorized by the following characteristics.

- Means of traction (tracklayer or wheeled)
- Type of power plant (diesel, spark ignition, or steam)
- Number of driving wheels (one, two, or four)
- Horsepower (from few to several hundred)
- Operators position (riding or walking)

Tractors are generally categorized into three groups: farm tractors, compact tractors, and pedestrian tractors. Farm tractors include tracklayers as well as wheeled tractors. The FAO data in Table 1.1 include all riding tractors and tracklayers of 8 hp or greater that are used for farm work. In North America, only tractors of more than 20 hp are normally considered farm tractors. Riding tractors less than 20 hp are called compact or garden tractors. Pedestrian tractors are also called walking tractors or tillers. They range from 2.5 to 15 hp and are controlled by the operator, who walks behind.

2.1 Engine power

Most agricultural tractors have four-stroke cycle engines. In a four-stroke cycle engine, the piston must traverse the length of its cylinder in a cycle of four strokes—intake, compression, power, and exhaust — for each power stroke.

In a two-stroke cycle engine, each piston traverses the cylinder twice for each power stroke. At the start of the first stroke, fuel is taken into the cylinder and the air-fuel mixture is compressed before the end of the stroke. The work

performed in two strokes (the intake and compression strokes) of the four-stroke cycle occurs within a single stroke in the two-stroke cycle. At the start of the second stroke, burning and expanding gases push against the piston face, providing engine power. Toward the end of this stroke, the gases of combustion are exhausted. Thus, the second stroke fulfills the functions of both the power and the exhaust strokes (the third and fourth strokes) of the four-stroke cycle engine. In small gasoline engines for pedestrian tractors (10 hp or less), the average two-stroke cycle engine provides a better horsepower-to-weight ratio than the average four-stroke cycle engine. The fuel efficiency of the two-stroke cycle gasoline engine, however, is poorer in this horsepower range.

Where flotation is a consideration, such as working in a ricefield, or where a man must carry an engine-powered piece of equipment such as a sprayer or mower, two-stroke cycle gasoline engines are used because of their smaller size. One of the chief problems encountered when using small, two-stroke cycle gasoline engines is that, since the lubricating oil is usually mixed with the gasoline, spark plug fouling is common.

Two-stroke cycle diesel engines are sometimes used on farm tractors of more than 100 hp. In a diesel engine, the initiation of combustion is controlled by the injection of the fuel. Since superchargers and exhaust scavengers are used on large, two-stroke cycle diesel engines, fuel efficiency is better than in small engines.

The average fuel requirement for a farm tractor with a standard transmission and a four-stroke cycle engine of more than 20 hp may be estimated if the maximum PTO hp is known. To estimate average fuel consumption, the following formulas can be used.

$$\text{Liters gasoline/h} = 0.227 \times (\text{max PTO hp at sea level})$$

$$\text{Liters diesel/h} = 0.1665 \times (\text{max PTO hp at sea level})$$

The above estimates are based on the average of the "Varying Power and Fuel Consumption" portion of the Nebraska Tractor Test, rather than on fuel consumption at maximum power (see Appendix D).

Altitude affects power. An internal combustion engine, in which air is sucked into the cylinders by the pistons, creating

a partial vacuum during the intake stroke, is called a naturally aspirated engine. A gasoline engine requires an air-to-fuel ratio by weight of 15:1. The ratio varies from about 19:1 to 8:1 depending on engine speed and fuel setting (lean or rich). At high altitudes, air is less dense, containing less oxygen than at sea level. Human beings and draft animals are similar to naturally aspirated engines because they respond to thinner air by delivering less power. The reduction in power of a naturally aspirated internal combustion engine can be described by the equation:

$$hp_x = \frac{hp_s \times \left(\frac{P_x}{P_s}\right)}{\left(\frac{T_x}{T_s}\right)^{0.5}}$$

where P = air pressure in inches of mercury
 T = temperature in degrees Rankin
 (Rankin = degrees Fahrenheit + 459.67)
 x = altitude
 s = sea level

In Peru, farming occurs over a wide range of altitudes. A 60-hp tractor sold in Lima (sea level) will not deliver 60 hp on the numerous high-altitude farms in the country. Table 2.1 reveals the difference in a tractor’s PTO hp in various agricultural regions of Peru.

The human body partially compensates for high altitude by increasing the number of red corpuscles, thus increasing the oxygen-bearing capacity of the blood. Similarly, the addition of a turbocharger or supercharger to a tractor’s engine can return the horsepower output to its sea level

Table 2.1. Effect of altitude upon tractor power in Peru.

Location	Altitude (m)	Power of 60-hp tractor (PTO hp)
Lima (sea level)	0	60
La Molina (coastal desert)	240	58
Ticlio (mountains)	4884	33
Huancayo (mountain valley)	3273	40
San Ramon (high jungle)	800	55
Yurimaguas (Amazon Basin)	179	58

rating. The advancement of spark timing in a spark-ignited engine also provides a slight improvement of power output at high altitudes.

2.2 Tractor horsepower

The word horsepower is somewhat confusing when applied to tractors, because there are various terms that refer to tractor horsepower, namely, engine brake, PTO, belt, and drawbar horsepower.

Engine brake horsepower does not include the losses that occur between the engine flywheel and the wheels or PTO shaft. For this reason, engine brake horsepower is represented by larger numbers than other forms of tractor horsepower. Engine brake horsepower measurements are sometimes made with the fan, water pump, and alternator connected to an auxiliary source of power so that the engine under test will indicate a high horsepower on the dynamometer. Automobile engines are often tested in this fashion.

Have you ever wondered why a passenger car engine is rated at several hundred horsepower while a farm tractor with an engine of the same size may be rated at less than 100 hp? Belt horsepower or PTO horsepower is the net power available at the PTO shaft, and is measured while the tractor is stationary. Belt horsepower or PTO horsepower is always less than engine brake horsepower. The power required by oil and coolant pumps, gear losses, and other power losses between the engine crankshaft and the belt pulley or PTO shaft represents the difference between engine brake horsepower and PTO horsepower. Maximum belt or PTO horsepower is numerically the highest reading taken from the complete tractor. Farmers use a belt pulley or PTO to power such implements as irrigation pumps, forage blowers, and hammer mills. The relative performances of such implements can be visualized by comparing maximum PTO horsepower.

Drawbar horsepower is a useful measure of horsepower, since it provides a direct comparison with draft animals, as well as with other tractors used for draft work. Drawbar horsepower, however, varies with changes in soil conditions, tire size, and tractor weight. Drawbar tests are usually performed on tarmac.

In the United States, the Nebraska Tractor Tests are the standard farm tractor tests. Nebraska tests are currently conducted only for tractors of 20 hp or greater. A typical

Nebraska Test report is shown in Appendix D. Engine brake horsepower tests are usually conducted in accordance with the Standards of the Society of Automotive Engineers (SAE) in the United States, or with Deutsche Industrie Norm (DIN) standards in Germany.

Tractor engines are fueled by diesel, gasoline, kerosene, or liquefied petroleum gas (LPG). The cost and availability of fuel often determine the type of engine used. Most farm tractors produced today are diesel powered. In some countries where gasoline or diesel is not readily available, pedestrian tractors frequently use kerosene.

2.3 Single-axle pedestrian tractor

Pedestrian tractors or tillers are usually classified as single-axle or double-axle units. Single-axle units (Fig. 2.1) have one powered axle, while double-axle units have two powered axles.

When single-axle tractors are used for draft work such as pulling a plow or a cart, the drive wheels are attached to the axle. For rotary tillage, the drive wheels are removed and tines are fastened to the axle. The tines both till the soil and propel the tractor forward. A retarding bar at the rear of the tractor controls travel speed and depth of tillage. To till deeper, the retarding bar is placed deeper into the soil to provide increased drag. As a result, forward motion is reduced and the

2.1. Single-axle pedestrian tractor.

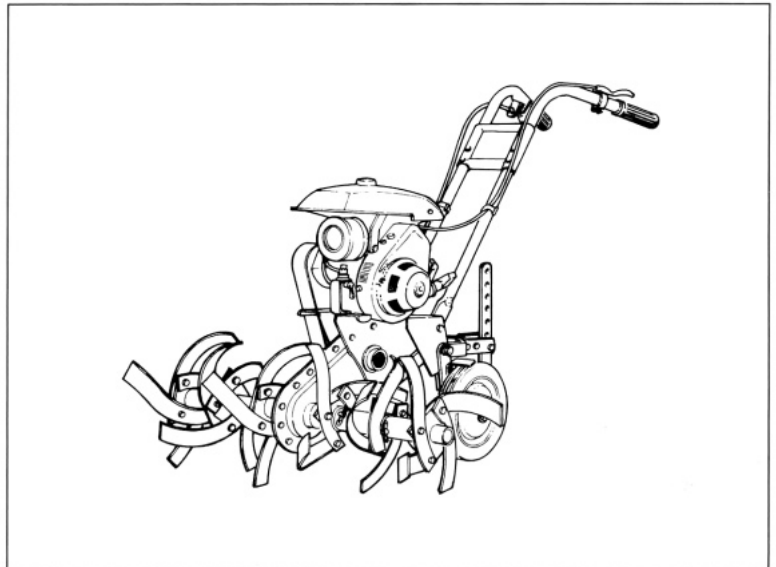

rotating tines make a greater number of slices per area of earth tilled, thus working the soil deeper.

Single-axle tractors are usually equipped with wide cage wheels and a moldboard plow in order to accomplish primary tillage in ricefields, which are usually flooded at plowing time. Secondary tillage of a ricefield is usually accomplished with a comb harrow, a puddler, or both.

The major components of a single-axle tractor are the frame, engine, transmission, and axle. The frame is a weldment fabricated from structural or formed steel shapes. The transmission case is usually an integral part of the frame. The engine is air-cooled. The type of fuel and the engine manufacturer are determined by economics. The most popular single-axle tractor use spark ignition engines in a range of 5-10 brake horsepower.

The transmission performs two functions. The primary function is to reduce the engine crankshaft speed of approximately 3600 rpm to an axle speed of approximately 50 rpm. The transmission's secondary function is to provide one or more speed reduction ratios, thus allowing slow speed for field work and greater speed for highway travel. A V-belt is generally used instead of a chain or gear drive for the first speed reduction step from the engine, since it not only can transmit power, but is used as an engine clutch. The operator uses a belt tightener as a clutch. The belt tightener is moved away from the belt to disengage the engine. The belt slips in the engine sheave so that no power is transmitted. A V-belt should operate at high speed and low tension, while a roller chain and sprocket drive should work at low speed and high tension. Double sheaves are often used on the V-belt drive of the single-axle tractor to provide two speed ranges. One set of sheaves provides field speed; the other set provides highway speed.

The transmission consists of the transmission case and the gear sets or chain and sprocket sets it encloses. The transmissions on most single-axle tractors make two speed reductions in the transmission case. The transmission case is liquid tight and contains oil to lubricate the gears or chains. Bearings at the bottom of the case support the axle.

Three types of wheels are used on pedestrian tractors: pneumatic tire, steel upland, and paddy. Lugged pneumatic tires are used where the tractor is to be used on dry fields, or

roads. In many parts of the world, steel upland wheels are preferred because they are less expensive than pneumatic tires. A typical steel upland wheel for a single-axle tractor is 75 cm in diameter and 20 cm wide with 13 blades. The paddy wheel is preferred for work in wetland fields. A typical paddy wheel for a single-axle tractor is 45 cm in diameter and 50 cm wide, with 12 blades per wheel. Not only does the wide paddy wheel provide better flotation than the narrower steel upland wheel, but it performs an acceptable job of puddling.

In the temperate zone, it is undesirable to smear the soil by the action of a wheel, since impervious layers adversely affect plant development. Soil consisting of crumbly particles allows oxygen into the soil.

A ricefield is entirely different. To retain water in the ricefield and to provide a favorable environment for the rice roots, the bottom of the field is worked into an impervious layer of small particles. This process is called puddling. The bottom of a ricefield is oxygen-deficient, but the rice plant has the ability to oxygenate the roots through the stem. Most weeds do not possess this unique feature, and thus are eliminated by drowning.

Tractor weight affects performance. In general a heavy tractor can convert more of its engine horsepower into drawbar pull than can a light tractor. In a ricefield, however, a lightweight tractor has an advantage because it has better flotation and is more easily maneuvered by the operator, who may be up to his knees in mud.

Most single-axle tractors are not equipped with steering clutches or a differential on the axle. The operator turns by grasping the handle and pulling sideways. Both wheels are driving, but one is forced to skid, and the turn is accomplished. This type of turn requires extra effort, but single-axle tractors are not heavy. One model, Landmaster™, has a reversing device for making a left turn, whereby actuation of a handlebar lever reverses the axle rotation. The left-hand wheel moves rearward, while the right-hand wheel remains stationary, since it is secured to the axle with a nonreversing clutch. The tractor thus makes a leftward pivot about the right-hand wheel.

Figure 2.2 shows the relationships between drawbar pull, slip, and horsepower for a typical single-axle pedestrian tractor. Note that the tractor weighed 175 kg (385 lb) for the

2.2. Drawbar horsepower and slip vs draft.¹

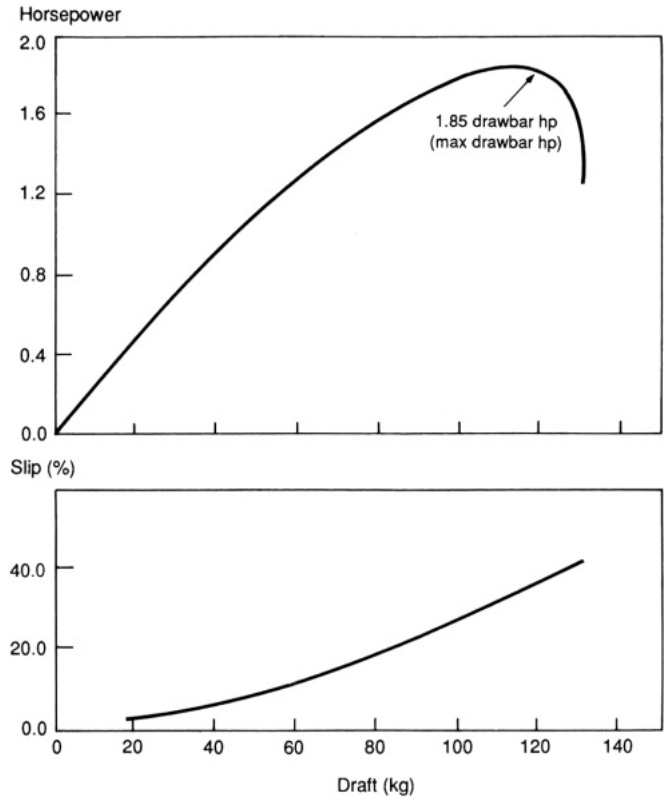

test and that steel upland wheels were used. The gasoline engine was rated at 7.25 maximum brake horsepower.

Some pedestrian tractors can perform a variety of functions. Figure 2.3 is an exploded view of a single-axle tractor such as the LandmasterTM or the IRRI PT-5 with tools and equipment.

A recent development from the Philippines is a range of floating rotary tillers for wetland rice production. These machines—the Turtle Tiller from an Iloilo manufacturer and the Hydrotiller series from IRRI (Fig. 2.4), have single or twin hull floats, respectively that help support the front-mounted high-speed rotor. These machines have been rapidly accepted in Southeast Asia because they can work in ricefields with water so deep (e.g., 0.5 m) to the hardpan that a single-axle tractor cannot be used, and even a water buffalo and plow would find it hard going.² They perform the functions of simultaneously puddling, leveling (hydrotillers only),

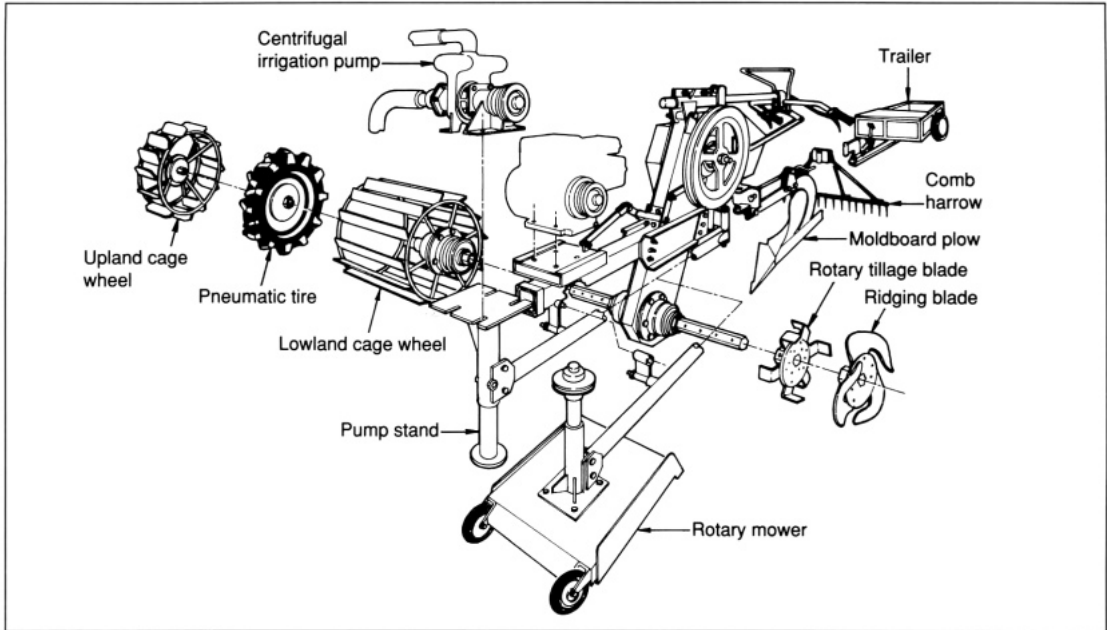

2.3. Single-axle pedestrian tractor and attachments.

2.4. Hydrotiller, a floating rotary tiller (IRRI twin-hull design).

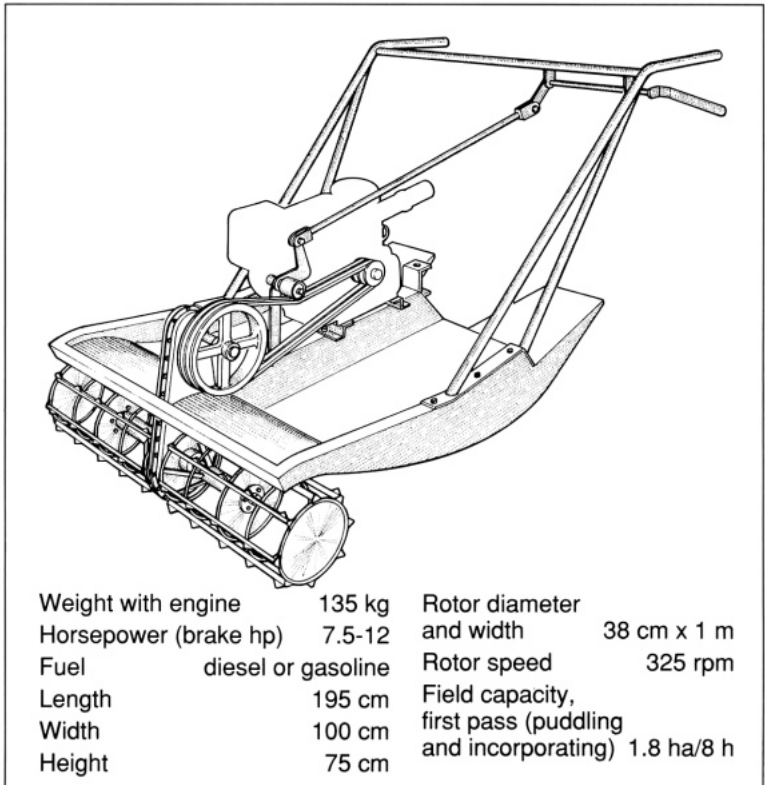

weeding, and green manure incorporation. They can work right to the edge of the field and even trim levee sidewalls, which is valuable benefit for weed control and rodent management. A drawback is that these are single-purpose machines that are not balanced for transport purposes on hard surfaces. For transport between sites, attachable outrigger wheels, a trailer, or a sled is needed.

2.4 Double-axle pedestrian tractor

The double-axle tractor (Fig. 2.5) is usually larger, more powerful, and more expensive than the single-axle tractor. It is used primarily for rotary tillage. It also serves as the power unit for a multitude of uses, from drawing trailers to pumping water. One axle propels the machine from the front, while the rear axle acts as a rotary tiller. There is a large variety of features for double-axle tillers. The remarks in this section refer primarily to the 8- to 15-hp models commonly used for farming in Southeast Asia.

A double-axle tractor is two to three times heavier than a single-axle tractor. However, since double-axle tractors are equipped with steering clutches and the forward speed of the drive wheels is independent of the rotor speed, the units are

2.5. Double-axle pedestrian tractor.

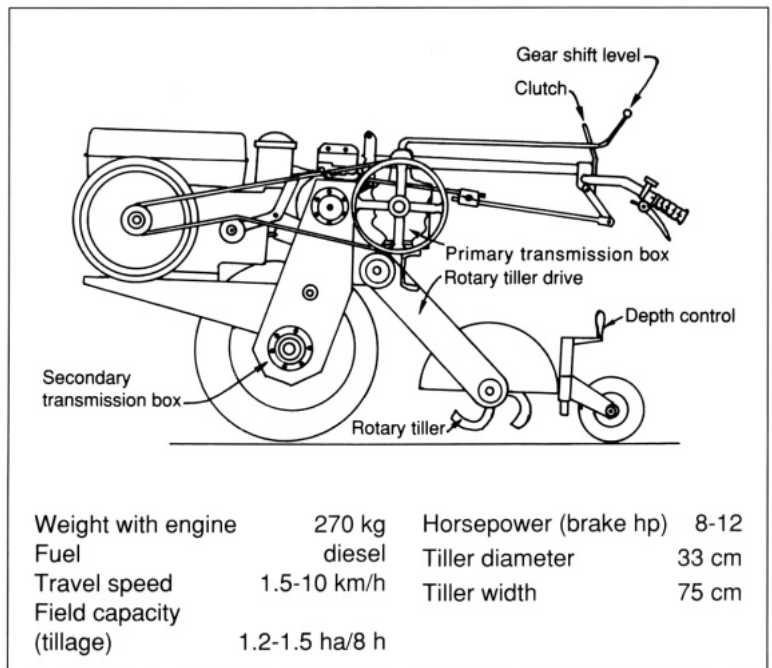

often less tiring to operate than single-axle tractors. In some double-axle tractors, the tiller shaft rotation is such that the blades tend to move the tractor forward at a high speed but are prevented from doing so by the drive wheels, which move the tractor forward at a speed selected by the operator. Tractors such as the Troy-bilt in the United States are easy to control when tilling unflooded land, even with one hand. To provide sufficient traction, these tractors are usually rear-heavy, with most of the weight being carried by the driving axle.

Double-axle tractors used in flooded ricefields perform better when the direction of rotation of the rotor shaft is the same as that of the drive wheels. The tiller blades assist in moving the tractor forward.

Double-axle tractors have various transmission arrangements. A common arrangement includes six forward speeds, two reverse speeds, and two rotor shaft speeds. Disc clutches are usually used instead of a V-belt and idler combination. Since the double-axle tractor is usually of greater horsepower than the single-axle tractor, the stronger (though more expensive) plate clutch provides better service than does the V-belt and idler type clutch.

2.5 Compact tractor

Compact tractors (often called garden tractors) are 4-wheeled tractors of less than 20 brake hp. In the USA, compact tractors are generally used more for lawn mowing than for agricultural work. A typical compact tractor is illustrated in Figure 2.6.

Two compact tractors designed primarily for agricultural work are the Self HelpTM and the Agro-UtilTM. Tests at Kansas State University revealed that these tractors, equipped with single 12-in (30-cm) moldboard plows, could plow 1 ha of wheat stubble in 11-14h. This figure includes time for turning, adjustments, and stoppages due to clogging.³

The range of hours required to plow a hectare was caused by differences in soils which ranged from clay loam to silty clay loam), the moisture content of the soil, and wheel weights. The Agro-UtilTM was equipped with a Wisconsin Model S-12D air-cooled gasoline engine, which develops 12.5 brake hp at 3600 rpm. The Self HelpTM tractor had a Wisconsin Model EY44W, which develops 10.5 brake hp at 3600 rpm.

The governed engine speed for these tractors was 2800 rpm. Plowing was conducted in second gear at approximately

2.6. Typical compact tractor.

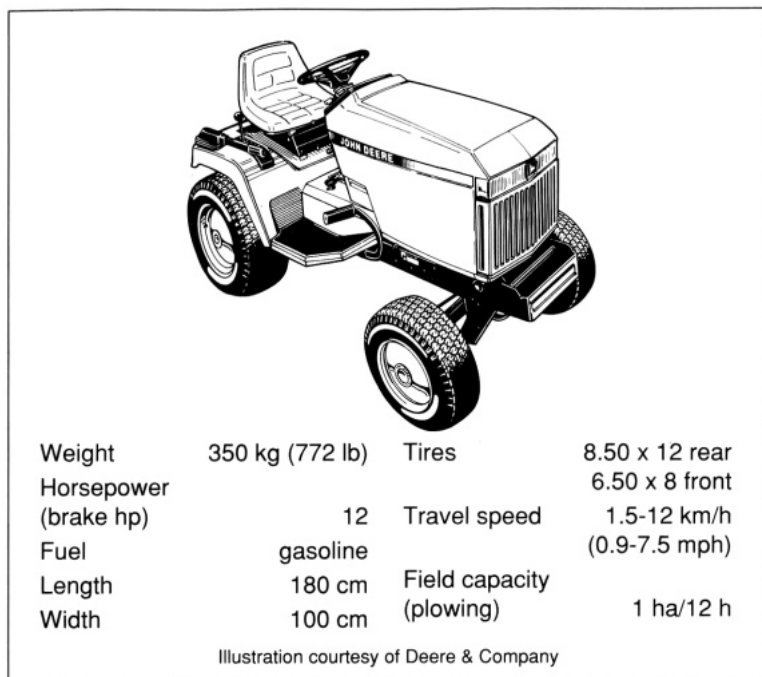

4 km/h (2.5 mph). The fuel consumption during plowing ranged from 21.5 to 42 liters gasoline/ha (2.3-4.5 U.S. gal/acre). Most compact tractors use gasoline engines, but a few use diesel.

Examination of the data in Table 2.2 illustrates the general principle that additional weight on a tractor's driving wheels will enable the tractor to convert additional engine power to

Table 2.2. Draft, drawbar horsepower, and wheel slip vs rear wheel weight for Agro-Util™^a

Static weight on rear wheels (kg)	Speed (km/h)	Draft ^b (kgf)	Wheel slip (%)	Drawbar power (hp)
451	4.5	200 (1961)	4.3	3.3
510	3.8	336 (3295)	17.2	4.6
573	3.5	430 (4217)	19.5	5.5
640 ^c	3.4	450 (4413)	16.7	5.6

^aBasic tractor weight on rear wheels was 451 kg, including weight of operator, water in tires, and concrete wheel weights. Drawbar tests conducted on firm soil with moisture content of 6.1% (dry basis).

^bFigures in parentheses are values in N.

^cEngine overloaded and not up to governed speed.

2.7. Compact tractor with rear-mounted engine.

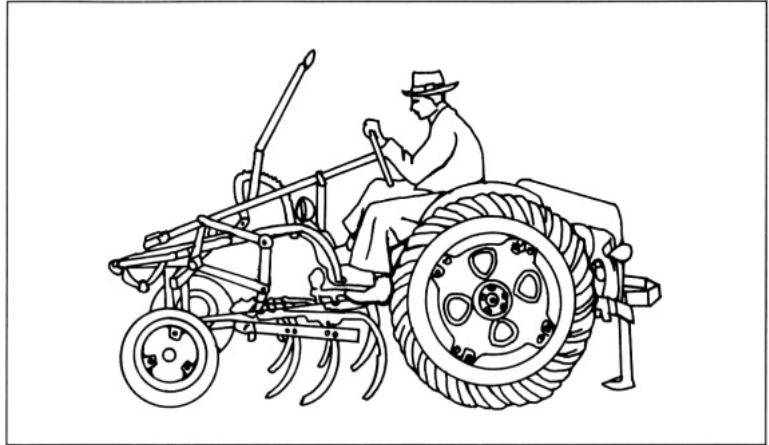

additional drawbar horsepower. In other words, the limit of engine power is reached when excessive slippage occurs. Some compact tractors have the engine over the rear wheels for additional weight (Fig. 2.7).

Without tools, tractors are useful only for transportation. Standards enable manufacturers of various compact tractors to use interchangeable implements. The American Society of Agricultural Engineers (ASAE) has established standards for drawbars, 3-point hitches, and 2000 rpm PTOs for compact tractors.

2.6 Farm tractor

The FAO data in Table 1.1 specify as farm tractors all riding tractors used for farm work. Since I have used the North American convention of designating riding tractors of less than 20 hp as compact tractors, I shall use the term farm tractors for riding tractors of 20 hp or more. When referring to farm tractor horsepower, maximum PTO horsepower is used unless another horsepower measurement is specified.

The State of Nebraska—home of the famous Nebraska Tractor Tests—requires the University of Nebraska to test at least one tractor of each model sold in the state. Results are published. A farmer can then use the test data to decide which tractor is best for his situation.

The Nebraska Tractor Tests originated during the early days of farm tractors, shortly after World War I. A Nebraskan farmer who was also a member of the Nebraska legislature purchased a tractor that did not perform up to its advertised claims. The farmer-legislator therefore introduced a bill

54 MECHANICAL POWER

providing that no farm tractor could be sold in Nebraska unless it had been tested at the University of Nebraska, and unless the manufacturer had made spare parts available in the state. Since no tractor manufacturer can afford to produce a special version of its tractors for sale in Nebraska, the Nebraska Tests became the standard performance tests for farm tractors sold in North America. A typical Nebraska Test is shown in Appendix D).

A rubber-tired farm tractor like the one shown in Figure 2.8 is generally more desirable than a tracklayer (Fig. 2.9), since it is less expensive, has high road and field speed, can be operated on asphalt highways without damaging the highway surface, and costs little to maintain. A tracklayer is preferred when farming is conducted on steep slopes or where very loose soils or organic soils require a high draft from a small tractor.

The rear wheels of farm tractors and most compact tractors can be braked independently if desired. The foot brake pedal is split so that if only the right rear wheel is to be braked, the driver pushes against the right-hand side of the pedal. To brake the rear left wheel, the left side of the pedal

2.8. Two-wheel drive farm tractor.

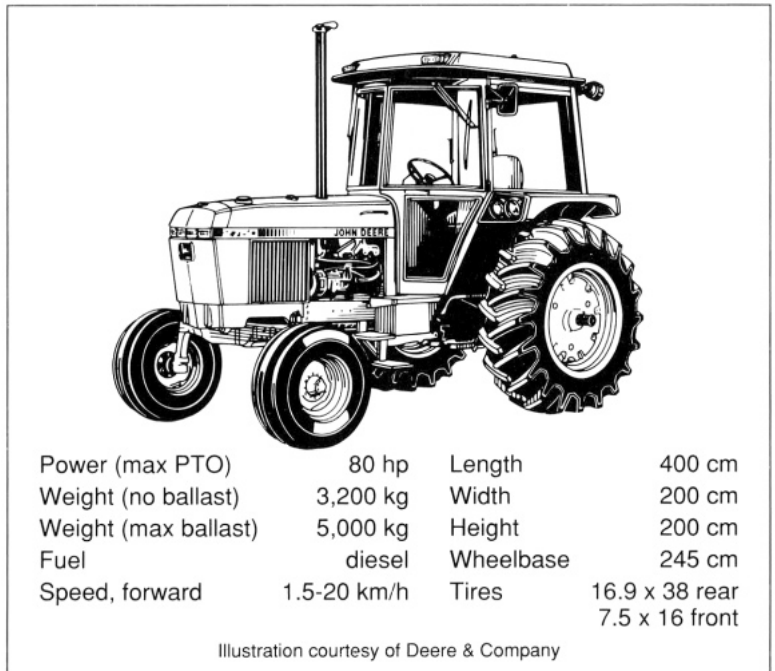

2.9. Tracklaying farm tractor.

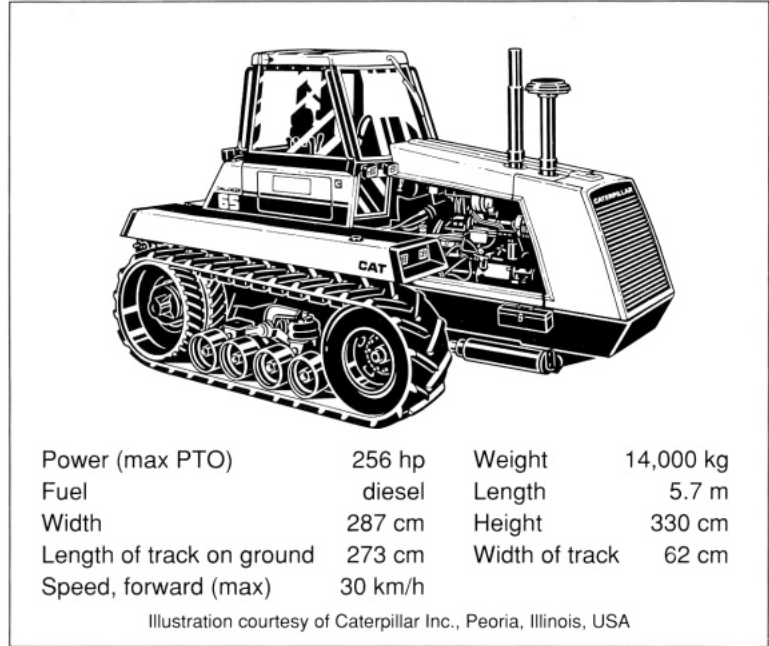

is depressed. By pressing equally against the face of the split foot brake pedal, both rear wheels are braked. Independent rear wheel brakes are a great aid in making short turns and steering in muddy fields. Most Farm tractors do not have front wheel brakes.

To convert engine horsepower into draft, high friction is required at the interface of the soil and the part of the tire contacting the soil. An extreme example of the principle is a rubber-tired tractor on ice. Although the tractor has a powerful engine, there is little friction. Therefore, the wheels spin, and draft and drawbar horsepower are zero. Traction is usually obtained by increasing the weight on the drive wheels. When the soil no longer supports the wheels, they sink further into the soil, and rolling resistance increases while draft decreases.

A tractor with front-wheel assist (Fig. 2.10) is a basic two-wheel drive tractor equipped with powered front wheels. The front wheels of most front-wheel assist tractors are driven through the same transmission as the rear wheels. The front wheels are driven at a speed that provides a tire speed equal to or about 1.05 times the speed of the rear tires. A few two-wheel drive tractors that have been retrofitted for front-wheel

2.10. Farm tractor with front-wheel assist.

assist use hydraulic motors to drive the front wheels. Mechanical drive is usually better than hydraulic drive, since the front and rear tire speeds remain in synchronization better with mechanical drive. All front-wheel assist tractors can be operated in either the two-wheel drive or the front-wheel assist mode with all four wheels powered.

On a hard surface a properly weighted two-wheel drive tractor will perform as well as the same tractor with front-wheel assist and the same gross weight with regard to wheel slip and drawbar power. In soft field conditions, the front-wheel assist tractor can develop greater drawbar power than the two-wheel drive tractor. A study in Nebraska used an 80-hp farm tractor equipped with front-wheel assist and operated in both the powered and nonpowered front-wheel modes on disked silty clay loam wheat stubble and on the same soil after it had been plowed to a depth of 20 cm and disked again.⁴ Tractor gross weight was kept at 5.105 kg (11,255 lb) in all tests. When in two-wheel drive, 74% of the weight was carried by the rear tires. In the front-wheel assist mode, the tractor weights were shifted so that 59% of the weight was carried by the rear tires. The tests showed that tractor weight distribution is very important when in the two-wheel drive mode: the drive wheels must carry most of the tractor's weight to reduce wheel slip. In the front-wheel assist mode, weight distribution is not very important. On the firm surface of disked wheat stubble,

the maximum drawbar power was about 65 hp for both modes, but on the soft surface of plowed and disked wheat stubble the tractor produced about 10% more drawbar power when in front-wheel assist mode. The advantage that a front-wheel assist tractor offers over a two-wheel drive tractor is dependent upon field conditions and the ballast weight distribution of the two-wheel drive tractor.

A basic difference between wheeled tractors designed for two-wheel drive and four-wheel drive is the location of the tractor's center of gravity relative to the axles. The two-wheel drive tractor has two-thirds of the tractor weight on the rear axle so that the weight is on the driving wheels: a four-wheel drive tractor places two-thirds of the weight on the front axle so that, under a heavy draft load, all tires will be equally loaded because of "weight transfer" due to the geometry of the hitching of the tractor to the load (see Fig. 2.11).

Worldwide standards help to make farm tractors versatile. Standards for three-point hitches, rear PTOs, and hydraulic couplers, and specification for hydraulic cylinders for implements make it possible for implements from various manufacturers to match with tractors made by other manufacturers throughout the world (Fig. 2.12). Farm tractor three-point

2.11. Four-wheel drive farm tractor.

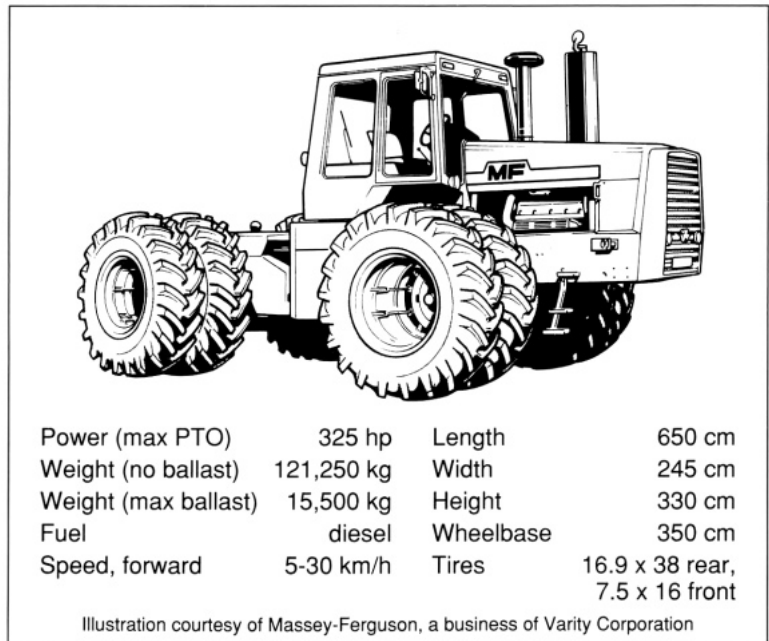

2.12. Rear 3-point hitch and PTO of a farm tractor.

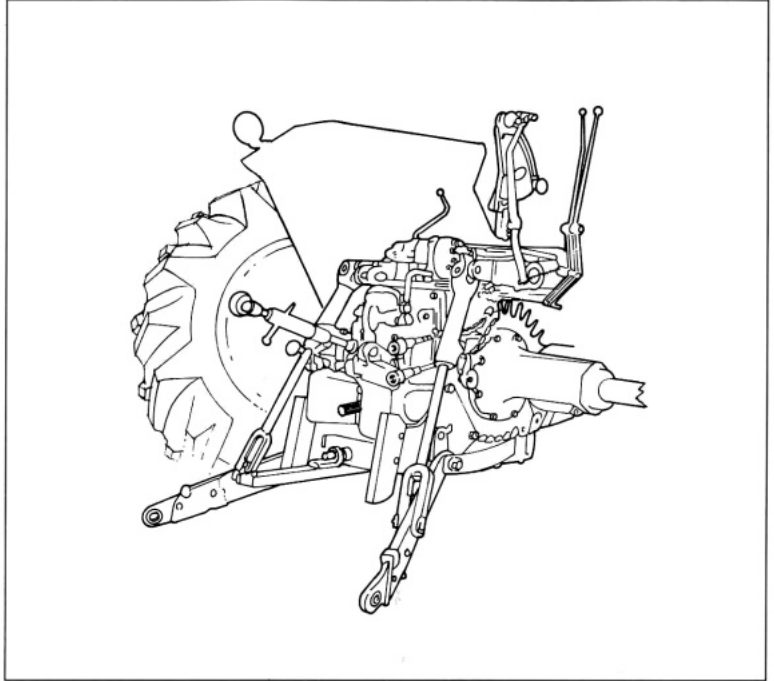

hitches are classified as Category I, II, III, or IV depending upon tractor power. Table 2.3 lists important dimensions and hitch lift capacity of the ASAE standard.⁵ By using hitch pin and hitch stud adapters, it is possible to use an implement of a lower category on a tractor of a higher category. For example, a category I implement can be hitched to a category II tractor by using adapters.

The two lower hitch links are powered by a hydraulic cylinder inside the tractor chassis. Lift height is controlled by a lever, which is usually mounted on the side of the fender or cab wall next to the driver. The upper link is not powered and

Table 2.3. Important rear 3-point hitch dimensions.

Category	Dwb power in hp (kW)	Upper link hitch pin diameter in inches (mm)	Lower link hitch stud diameter in inches (mm)	Lift force of hitch in lb (kN)
I	20-45 (15-35)	3/4 (19)	7/8 (22)	1040-2340 (4.6-10.8)
II	40-100 (30-75)	1 (25)	1 1/8 (28)	2080-4810 (9.3-21.7)
III	80-225 (60-185)	1 1/4 (32)	1 7/16 (36)	4160-8060 (18.6-36.1)
IV	180-400 (135-300)	1 3/4 (45)	2 (51)	6890-12,610 (31.0-56.6)

serves only to keep the implement stable as the lower links lift or lower the implement. Most farm tractors have rear three-point hitches that can also be set in a draft control mode. In draft control, the three-point hitch will keep constant the amount of draft force exerted by an implement such as a plow by lifting the implement to reduce draft when the draft limit set by the driver is exceeded. If the draft falls below the setting, the hitch automatically lowers the implement further into the soil to increase the draft. Draft control will prevent stalling a tractor when plowing a field with varying soil resistance, but in soil with great variation in resistance, a tractor in draft control mode will plow shallower than desired under some conditions and deeper under others.

Some three-point hitches are designed so that, by means of linkage, a downward force from the lower lift arms can be transferred to a trailing implement such as a disc harrow.

Farm tractors come equipped with both a rear three-point hitch and a swinging drawbar hitch. Depending upon the implement, the swinging drawbar may be removed from the tractor when using the three-point hitch, and the lower and upper links of the three-point hitch may be secured out of the way when using the swinging drawbar. A drawbar hitch consisting of a steel bar with several drawbar pin holes at midsection and a stud at each end to fit the lower links is also commonly used with a three-point hitch. To meet ASAE standards, tractor drawbars must withstand a minimum static load at the hitch point ranging from 3.34 kN (750 lb) for a 20 dwb hp tractor to 24.5 kN (5500 lb) for 500 dwb hp.⁶

Important dimensions of the ASAE standard 7 for rear PTOs and swinging drawbar hitches for farm tractors are listed in Table 2.4. The direction of rotation of all farm tractor rear PTOs is clockwise when standing behind the PTO and facing in the direction of forward travel. Some tractors have both type 1 (540 rpm) and type 2 (1,000 rpm) rear PTOs so that both 540 rpm and 1,000 rpm implements may be used with one tractor. It is not possible to operate an implement designed for 540 rpm by a tractor with a 1,000 rpm PTO or vice versa.

Some farm tractors are equipped with front three-point hitches and PTOs. In general, the dimensions of the front three-point hitches are the same as those of rear three-point hitches, but there is no general agreement yet on the direction of rotation and spline dimensions for front PTOs.

Table 2.4. Important rear PTO and drawbar hitch dimensions.

Type	Nominal diameter in inches (mm)	Splines (no.)	Standard speed (rpm)	Hitch pin diameter in inches (mm)	End of PTO shaft to hitch pin hole in inches (mm)	Height of drawbar above ground in inches (mm)
1	1 3/8 (35)	6	540	3/4 (19)	14 (356)	13-22 (330-559)
2	1 3/8 (35)	21	1000	3/4 (19)	16 (406)	13-22 (330-559)
3	1 3/4 (45)	20	1000	1 1/4 (32)	20 (508)	13-22 (330-559)

To convert the energy developed by a tractor's engine into useful draft, sufficient friction must be developed between the driving tires and the roadbed or soil surface. If the frictional force is too small, excessive wheel slip and an attendant loss of power result. To increase drawbar pull, the driving wheels are usually weighted and equipped with lugged tires, which grip the soil.

Tractor drive tires are made in four basic classes designated by the tire industry with an R code: R-1, regular agricultural tire; R-2, rice and cane tire; R-3, sand and industrial tire; and R-4, industrial lug. A class of low pressure tires sometimes referred to as a "terra-tire" does not have an R designation.

R-1 (regular agricultural) is the basic agricultural tractor drive tire with widely spaced lugs for general farming.

R-2 (rice and cane) is the same tread design of R-1 except it has lugs that are twice the depth of R-1 lugs in order to provide traction in very muddy conditions. Because of lug height, tires with R-2 tread are less stable and wear less well on the road than R-1 tires.

R-3 (sand and industrial) has closely spaced buttons in place of the traditional lugs. The R-3 tread depth is 60% of the depth of R-1 lugs. The tires are used on sandy soils and conditions such as golf courses where minimum lug penetration is necessary.

R-4 (industrial) lugs are wider, more closely spaced, and only 70% of the lug depth of the R-1 tread. The tire is used for abrasive conditions and is often seen on tractors used in highway construction.

The low pressure terra-tire has a wide tread that provides a large "footprint" for low ground pressure and good flotation. The low inflation pressure and the tire's construction provide

high shock absorbing capability. The tires can be identified by their very low ratio of tire diameter to width.

Front tires for two-wheel drive farm tractors come in three basic classes, F-1, F-2, and F-3.

F-1 (single rib) has a single rib.

F-2 (regular agricultural) is available in the greatest number of sizes and is the one most commonly seen on two-wheel drive tractors.

F-3 (industrial multiple rib) is the front tire analogous to the R-4 tractor drive tire.

Tractor tires are available in both bias and radial construction. Most tractor tires are of the bias type. Radial tires have slightly improved traction, resist sidewall torque buckling, and last longer than bias tires; but radial tires are usually more costly than bias tires. A radial tire is identified by an R after the tire size, which is molded into the tire sidewall.

Drawbar pull is developed when the tire lugs penetrate the soil surface and tend to shear the soil. Different soils have different shearing strengths. The amount of moisture in the soil also affects shearing strength. The shearing strength of the soil depends on the cohesion of the soil particles and the weight of the wheel on the soil. Increasing the weight of the wheel interlocks the soil particles more tightly, and the shearing resistance is increased. Drawbar pull can increase to a point where the shearing resistance of the soil is no longer great enough to withstand the increased force from the tire lugs. At this point, wheel slip becomes excessive. Actually, there will always be some wheel slip, and the greater the drawbar pull, the greater the wheel slip.

Maximum drawbar pull is obtained when wheel slip is as high as 50-70%. Since high slip causes high loss of power, however, most farm tractors are weighted and tired so that wheel slippage does not exceed 15%.

Since wheel slip and loss in forward speed are in direct proportion, wheel slip can be easily calculated in the field. First, a mark is made on one of the tractor's drive wheels. Second, with the tractor pulling an implement at working load or working depth, the distance traveled by the tractor in 10 revolutions of the wheel is marked off on the ground. Third, the load is disconnected, and the number of revolutions of the wheel over the same distance is counted. Since there is no drawbar pull during the second part of this test, there will be

less wheel slippage, and fewer revolutions (revs) are required to travel the distance. Wheel slip can be calculated as follows:

$$\% \text{ wheel slip} = \frac{10 \text{ revs} - \text{no-load revs}}{10 \text{ revs}} \times 100$$

Rolling resistance of a wheel must first be overcome before the wheel will move (Fig. 2.13). Rolling resistance occurs primarily because the weight of the tractor causes the wheel to sink into the ground. As a result, when the wheel is moved forward, it must run up the small incline formed as it moves ahead. A heavily loaded wheel on soft soil sinks in deeply, and the rolling resistance increases. Subject to the same weight, a tire with a large diameter will generally have less rolling resistance than a tire with smaller diameter, a wide tire less rolling resistance than a narrow tire, and a tire with low pneumatic pressure less rolling resistance than the same tire at high pressure.

The generalities delineated above refer to machines operating on soil. On a rigid surface such as concrete, where no sinkage occurs, decreasing tire pressure may in fact increase rolling resistance because of increased tire deformation. As illustrated in Figure 2.13, there is a constant trade-off between increasing weight to reduce slip and decreasing weight to reduce rolling resistance.

Traction aids are sometimes used with wheeled farm tractors to improve draft capability in difficult conditions. A

2.13. Drawbar power loss vs tractor weight.

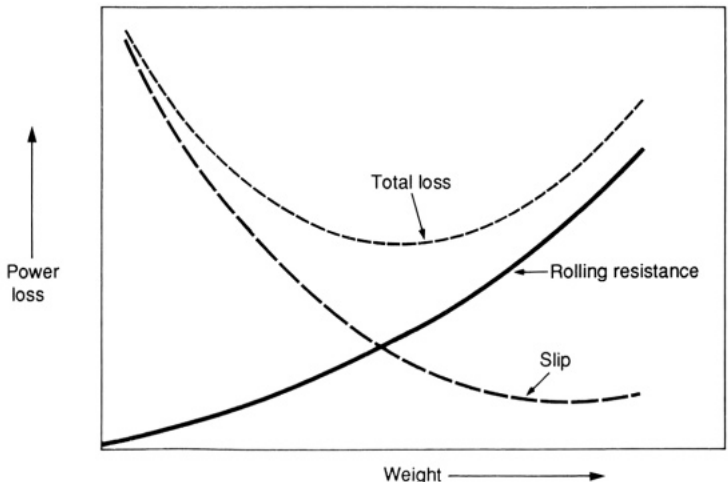

study of traction aids for a typical 45-hp farm tractor was conducted at the University of Guelph, Ontario, Canada.⁸ Traction aids were tested on five land conditions: dry and loose, cultivated sandy loam; damp, cultivated medium loam; wet and green stubble on medium loam; frozen alfalfa sod on medium loam: and sparse hay aftermath on wet heavy clay. Figure 2.14 presents the findings of the study.

Soil condition is one of the primary variables affecting traction, but the relative effectiveness of the various traction aids remains in the same ranking for all five soil conditions. The Canadian tests revealed that traction aids increased drawbar pull up to 2 1/2 times that obtained from the unballasted, 2-wheel drive farm tractor. The tests further showed that tire chains do not improve traction on sandy soils. On frozen sod, chains provide about 17% additional drawbar pull. About 6% additional draft can be obtained on the other soil conditions.

Large diameter tires improve traction. By increasing tire diameter from 13.6 x 28 to 14.9 x 28, traction is increased by 14%. The 13.6 x 28 tire has a loaded radius of 59.7 cm, while the 14.9 x 28 has a loaded radius of 62.2 cm. The larger tires in this test showed least traction improvement in dry sandy

2.14. Performance of traction aids on a 45-hp 2-wheel drive farm tractor.

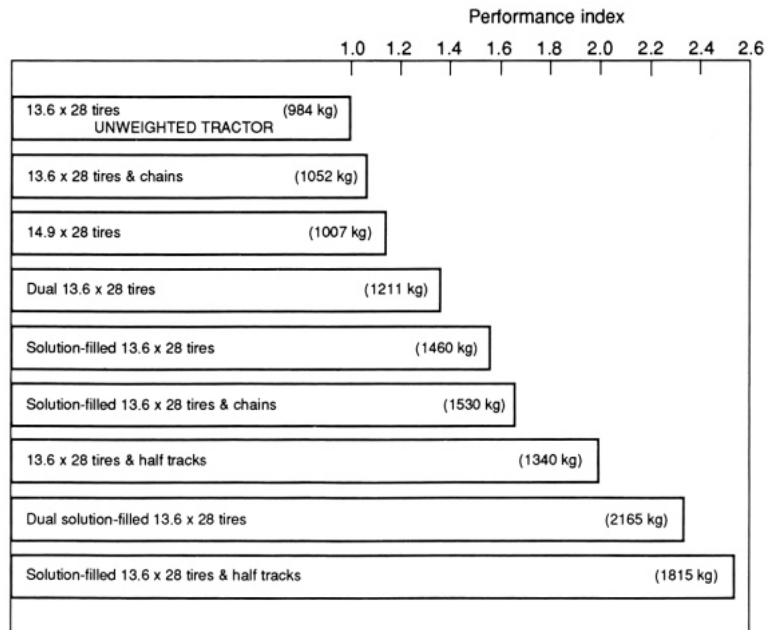

loam and greatest improvement in sparse hay aftermath on heavy clay.

Unweighted dual tires will provide about 1/3 more traction than unweighted single tires. The unweighted duals exhibited least traction improvement on dry sandy loam and the greatest improvement on sparse hay aftermath on wet heavy clay.

Half-tracks in this test were endless steel tracks 50 cm wide fitted over each rear drive tire, and a spring loaded idler wheel mounted ahead of each rear wheel. The half-tracks doubled the drawbar pull on all five soils.

Weight is the most common and one of the most effective traction aids. If weight is added, drawbar performance can be increased by half. Dual tire equipped tractors and half-track equipped tractors also produce greater drawbar pull if weight is added to the drive wheels.

As illustrated in Figure 2.14, a farm tractor equipped with solution-filled single tires can pull a greater load than the same tractor equipped with dual tires without weights. Weight can be added to a tractor by bolting weights onto it, by placing dry ballast such as lead shot inside the tires, or by filling the tires 75-90% full with a solution of calcium chloride and water. The calcium chloride keeps the water from freezing. If a pneumatic tire is filled to more than 90% with a water solution, the tire will lose its performance characteristics, since water is not compressible.

Pedestrian tractors respond to additional weight and various wheel and tire configurations in a manner similar to four-wheeled farm tractors. Figure 2.15 illustrates the effect of various types of wheels and tires on the draft of a single-axle pedestrian tractor operating on upland clay soil with a moisture content of 22%. A ballasted weight of 286 kg was used for the tests. The normal weight of this tractor is 112 kg. The tires with town and country tread were 6-13.00, 6-ply pneumatic, while those with bar tread were 5-12.00, 2-ply pneumatic. Both sets of tires were inflated to 145 kPa (21 psig).

An examination of Figure 2.15 reveals that heavily ballasted pedestrian tractor operation on upland soil provided draft with the least amount of slippage when equipped with pneumatic tires with the town and country tread. At 150 kg of drawbar (dwb) pull, the town and country tires had a wheel

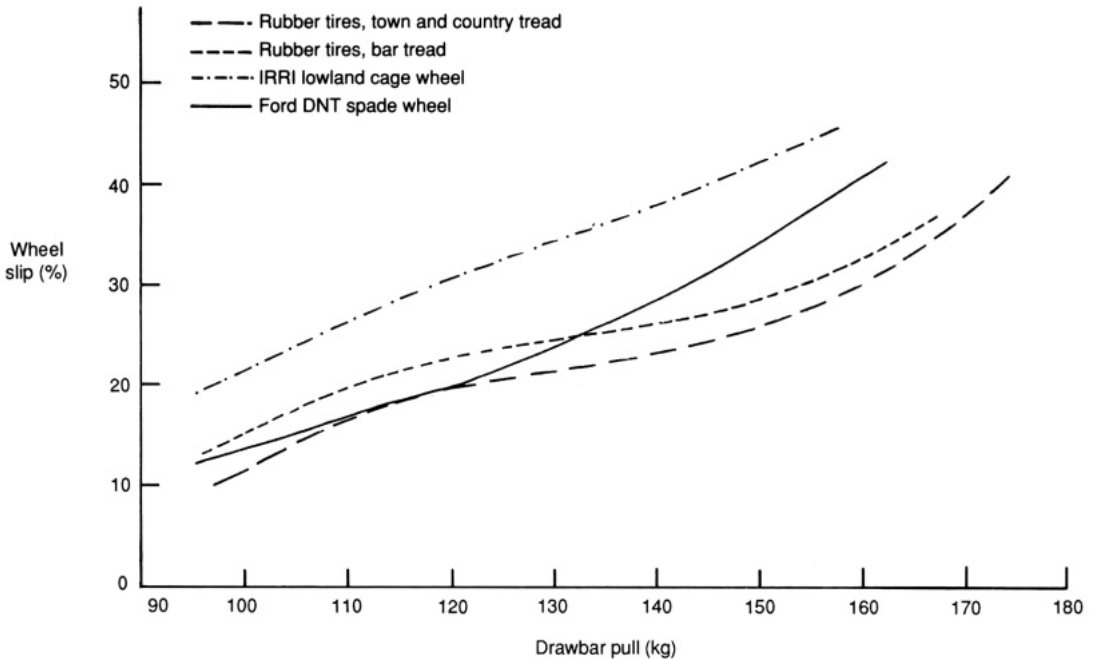

2.15. Wheel slip vs drawbar pull for a single-axle pedestrian tractor.⁹

slip of approximately 25%, while the tractor equipped with lowland cage wheels had a wheel slip of 40%. Although the draft was identical in each case (150 kg), the tractor with the greater wheel slip had slower forward speed. The drawbar horsepower of the tractor with the lower wheel slip was higher, since

$$\text{dwb hp} = (\text{speed} \times \text{draft}) \times (\text{a factor})$$

Thus, the tractor equipped with town and country tires provided a higher drawbar horsepower than the tractor equipped with lowland cage wheels.

Traction in conditions providing poor flotation, such as flooded ricefields, presents a different problem. In such conditions, weight is a hindrance, since additional weight sinks the tractor deeper into the mud, thus increasing its rolling resistance. This situation calls for a lightweight tractor. Lowland cage wheels for a pedestrian tractor and wheel strakes for a farm tractor will also improve traction and, in the case of tilling flooded ricefields, will aid in puddling the soil. Oversized tractor tires inflated to a low pressure will also aid flotation and traction. Researchers at Centro Internacional de Agricultura Tropical (CIAT) have found that the performance

of 60- to 80-hp 2-wheel drive tractors working in mud can be improved by using oversized tires.¹⁰ By purchasing the rims normally used with the next largest class of tractor, it is possible to install the high lug rice and cane tires of sizes 23.1 x 26 or 23.1 x 30. These tires are inflated to 34.4 kPa (5 psig). No water ballast is added to the tires, and no rear wheel weights are attached. These low-pressure, oversized tires provide much better flotation and mobility in the mud of ricefields. Disadvantages of this system are the high cost of the large rims and tires, and the need to space the tractor fenders upward so they are not struck by the tires. If a tractor equipped with oversized tires is used for dryland work, the tires must be inflated to normal air pressure. When inflating tractor tires to only 34.4 kPa (5 psig), it is necessary to use a water manometer to measure tire pressure, since the common tractor tire gauge is not accurate at low pressure.

A rotary tiller has negative draft and may actually push the tractor forward. A rotary tiller as used on a double-axle pedestrian tractor or a farm tractor is usually designed so that the tine action moves the tiller forward as it rotates. Thus the tractor can be lightweight, since it serves only as a chassis and steering mechanism for the engine. This is one of the primary reasons for using rotary tillage in flooded ricefields.

2.7 Single-wheel pedestrian tractor

The single-wheel pedestrian tractor (Fig. 2.16) is powered by a 5-brake hp, air-cooled, gasoline engine and is used primarily as a self-propelled cultivator and a power unit for drawing a small trailer. Although the unit is characterized by its large,

2.16. Single-wheel pedestrian tractor.

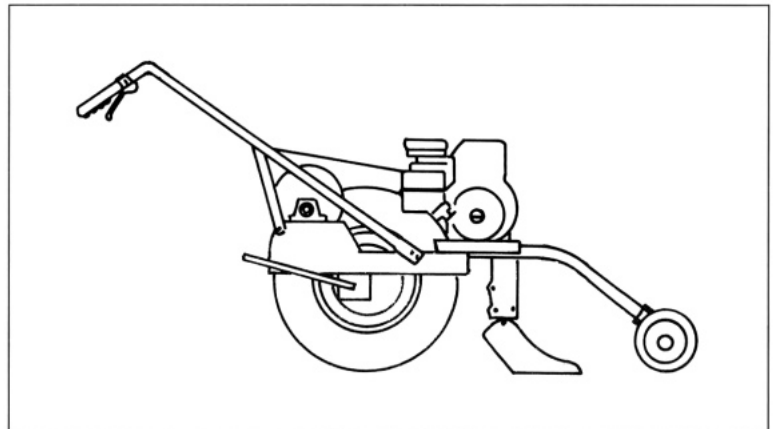

single drive wheel, the machine actually has two wheels in contact with the ground during cultivation. The second wheel is a small guide wheel in front of the tractor. The guide wheel provides depth control and resistance to side thrust when cultivating with a single curved shovel, which throws earth to the side.

2.8 Motorcycle tractor

The motorcycle tractor (Fig. 2.17) is primarily a transportation vehicle that can be used as a small agricultural tractor. The two-wheel drive motorcycle tractor is preferred to the one-wheel drive model because the former provides better traction. When used with an outrigger wheel to provide stability and operator comfort, the unit is actually a tricycle tractor. The motorcycle tractor is useful in slash-and-burn agriculture (shifting cultivation), where it is necessary to work around trees. It is possible to add weight to some models by filling the center portions of the wheels with water or fuel.

2.17. Two-wheel drive motorcycle tractor.

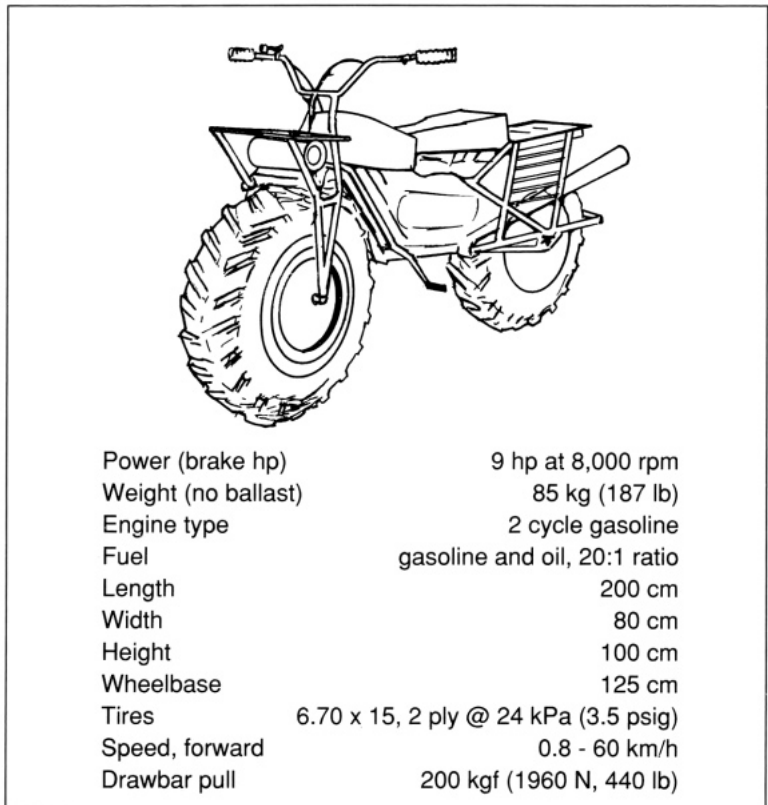

The motorcycle tractor is not suitable for ricefield cultivation because the engine is set low to the ground and would be damaged by water or mud. Furthermore, it is impossible to use cage wheels with the unit.

2.9 Winch systems

In the British Isles during the 1800s, some plowing was accomplished by using steam-powered winches to draw plows across a field as shown in Figure 2.18.¹¹ That is why we refer to the grades of wire rope as plow steel. In the early 1900s, plowing by cable systems was carried out in Californian sugar beet fields and Hawaiian sugarcane fields.

Several types of cable systems were used during the 1800s. The most successful was the double engine and cable method. Two steam tractors equipped with winches were aligned on opposite ends of a field. Each winch drum contained 300-420 m of cable. A plow, harrow, or other tool was attached to the cable. While one engine played out the cable, the other engine wound it in, thus drawing the plow across the field.

When a pass across the field was completed, both steam tractors were advanced a distance equal to the width of the gang of plows. Two-way plows were used so that the furrows were thrown properly regardless of direction in which the unit was drawn.

In England, master-slave rigs were used which required only one steam tractor with a winch and a double cable. The slave was a heavy wheeled vehicle equipped with a large, anchored pulley. The steam tractor (master) was set up on

2.18. Plowing with cable-drawn plows.

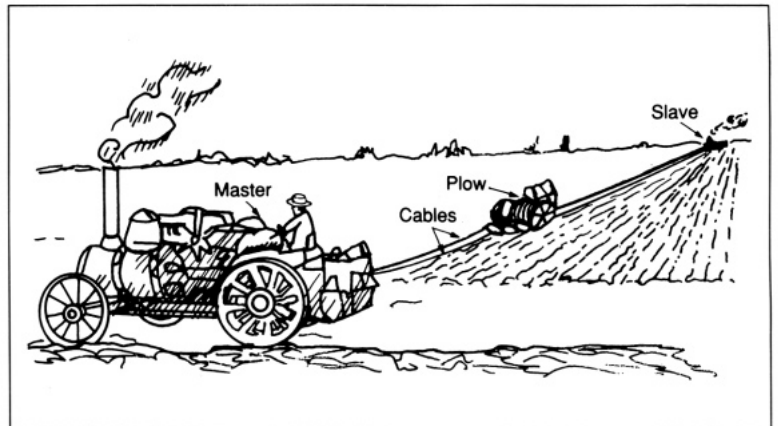

one side of the field and the pulley (slave) on the other. The endless cable would be wrapped several turns around the winch drum. As the master winch rotated in one direction, the cable drew the implement across the field. When the implement reached the slave, the master stopped the winch, and the operator of the implement reversed the direction of the tools. Both master and slave moved forward a distance equal to the width worked by the implement. The operator of the master then engaged the winch in reverse, thus drawing the implement back toward the master.

The cable system used in the 1800s utilized the heavy, massive steam engines of the day as a source of drawbar power for tillage. With the cable system it was possible to plow boggy lands where heavy tractors would sink. The land was not compacted by a heavy tractor, and the entire brake horsepower as measured at the winch was available for drawing the implement. There were also disadvantages, the primary one being the high investment cost. Also, because of the length and weight of the cables, the system was restricted to small fields of rectangular shape.

A third type of cable system was the roundabout system.¹² In this system, the steam engine and winch were either positioned in one corner of the field with anchors deployed to hold large pulleys placed in the other corner; or the engine was located in the center of one side of the field while four anchors with pulleys were placed in the corners of the field. The cable was run around the field's periphery, and the implement was drawn back and forth across the width of the field. After each pass, the two anchors directly in line with the implement were moved a distance equal to the width of the implement.

Cable systems utilizing a single cable wound onto a winch and side-mounted on a four-wheel farm tractor are in use in European vineyards today. The system makes it possible to cultivate very steep slopes with mechanical power. The tractor, with its side-mounted winch, drives up the slope following the contour of the land. The implement to be drawn is placed at the bottom of the slope. When the tractor is in position, the operator of the implement takes the free end of the cable, pulls it down the slope, and attaches it to the implement. The tractor driver then engages the winch and draws the implement and its operator up the slope. The

tractor moves across the slope to a point between the next pair of trellises, and the procedure is repeated.

A winch and cable system using a pedestrian tractor has been adapted for use in LDCs. The system is called the Snail tractive system.¹³ The Snail system consists of a self-propelled winch that looks like a pedestrian tractor, a 30-m cable, and a modified ox-drawn implement. The system requires two operators. One operator drives the self-propelled winch forward, stops it, engages the winch, and draws the tool toward the winch. The second operator guides the tool as he would using oxen. Since one operator rests while the other is working, fatigue is relieved.

The Snail uses a 3-brake-hp gasoline engine as a power source. The unit is able to achieve a draft of 400-500 kgf (3.9-4.9 kN, 880-1100 lb) at a cable speed of about 1.5 km/h. A sprag plate acts as an anchor and prevents the lightweight self-propelled winch from moving toward the tool. The cable from the Snail is near the ground and parallel to it, so some adjustment to the hitch point of the ox-drawn implement is required, because the line of pull from an ox yoke to the implement is at a steep angle.

Nylon rope was used for cable in the early tests, but it was unsuitable because of excessive stretch and short life. Furthermore, the sudden release of energy and the whip of the rope when it breaks is very dangerous and can cause serious injuries to equipment operators. Steel cables are now utilized almost exclusively.

If fossil fuels become more expensive, cable systems powered by electric motors—either by battery or direct power line—may be economically feasible in some agricultural areas.

REFERENCES CITED

1. Thongsripong M, Phongsuprasamit S. Buyawanickul S (1974) Design and testing of a small power tiller. Project Report A74-3. Khon Kaen University, Thailand.
2. Villaruz M S (1986) The floating power tiller in the Philippines. Pages 173-178 *in* Small farm equipment for developing countries. International Rice Research Institute, P.O. Box 933, Manila.
3. Larson G H, Jensen J C. Schield V L, (1976) Evaluation of small 4-wheel riding tractors for developing countries. ASAE Paper 76-1014. American Society of Agricultural Engineers, St Joseph, Michigan.

4. Bashford L (1985) Axle power distribution for a front-wheel assist tractor. *Trans. Am. Soc. Agric. Eng.* 28(5):1385-1388.
5. American Society of Agricultural Engineers (1985) Three-point free-link attachment for hitching Implements to agricultural wheel tractors. Pages 133-135 in ASAE standards. 32d ed. St. Joseph, Michigan.
6. American Society of Agricultural Engineers (1985) Operating requirements for tractors and power take-off drive implements. Page 112-113 in ASAE standards. 32d ed. St. Joseph, Michigan.
7. American Society of Agriculture Engineers (1985) Rear power take-off for agricultural tractors. Pages 107-110 in ASAE standards. 32d ed. St. Joseph, Michigan.
8. Southwell P H (1954) An investigation of traction and traction aids *Trans. Am Soc. Agric. Eng* 7(2):190.
9. International Rice Research Institute, Agricultural Engineering Department (1977) Semiannual progress report no. 24. P.O. Box 933, Manila p. 23-24.
10. Johnson L, Alfonso D D (1974) A continuous rice production system. *Info. Bull.* 2-E. Centro Internacional de Agricultura Tropical Cali, Colombia.
11. Ellis L W, Rumely E A (1911) *Power and the plow*. Doubleday, Page & Co., Garden City, New York
12. Fussel G E (1952) *The farmers' tools*. Mayflower Press, London
13. Crossley C P, Kilgour J (1978) Field performance of winch-powered cultivation design in Central Africa. *J. Agric. Eng. Design* 23: 385-396.

BIBLIOGRAPHY

- American Society of Agricultural Engineers (1983) *Agricultural engineers yearbook*. St. Joseph, Michigan
- Branch D S, ed. (1978) *Tools for homesteaders, gardeners and small scale farmers*. Rodale Press, Emmaus, Pennsylvania.
- Kline D E, Bender D A, Le Pori W A, Schueller J K (1985) Optimization of automated cable-drawn tillage systems. ASAE Paper 85-1521. American Society of Agricultural Engineers, Chicago.
- Sullivan H D (1988) Role of the U.S. tractor industry in O.E.C.D. testing. ASAE Paper 88-1509, American society of Agricultural Engineers. St. Joseph, Michigan. 30 p.
- Visagie A (1977) Tractor performance. Eng. Ser. B.3/1977. Department of Agriculture, Technical Services. Silverton, Transvaal, South Africa.
- Wahlen, D J (1988) Rating of engines for outdoor power equipment. ASAE Paper 88-1527. American society of Agricultural Engineers. St. Joseph, Michigan. 14 p.
- Westley S B, Johnston B F, eds. *Proceedings of a workshop on farm equipment innovations for agricultural development and rural industrialization*. Occasional Paper 16. Institute for Development Studies. University of Nairobi, Nairobi.

3 Agricultural production systems

It is in the agricultural production system where land, vagaries of nature, energy, tools, and machines are brought together to grow food and fiber. For an agricultural production system to produce crops in a dependable and economical manner, the various components must be complementary. It is not easy to obtain a good relationship at the interface between mechanical devices requiring uniformity, land, and plants with biological diversity, but it is not difficult to mismatch the elements and degrade an agricultural production system. One must understand the agricultural production system before recommending a tool or machine for that system.

Agricultural production systems, cropping systems, soil, and soil compaction are discussed in this chapter.

3.1 Climate, soil, and farming systems

Climate and soil conditions vary enormously throughout the world, and farming systems successful in one region sometimes prove disastrous in another. A certain amount of regional prejudice concerning farming techniques is therefore quite understandable. For example, the techniques used in the soils of Illinois cannot be successfully duplicated in Latosols of West Africa. Similarly, the evenly spaced rains of the northeastern United States provide dramatically different farming conditions from the monsoons of western India.

Because of differences in soils, rainfall patterns, temperature, and social structure throughout the world, three primary types of agricultural production systems have developed: shifting cultivation, polyculture, and monoculture. Mechanization varies according to the agricultural production system practiced.

When faced with an agricultural system foreign to one's experience, it is wise to learn how it evolved. It is equally

important to consider the advantages and disadvantages of the system's adaptation to the specific conditions where it is employed.

3.2 Shifting cultivation

Shifting cultivation is a farming system in which a plot of land is cultivated for several years, after which it is temporarily abandoned and another plot is cleared and cultivated. While not under cultivation, the first plot is allowed to rejuvenate. The rest phase is usually longer than the growing phase. The temporarily abandoned land is returned to cultivation when its fertility is restored, or sooner if population pressure makes new land unavailable. About 36,000,000 km² under shifting cultivation are currently producing food for 8% of the world's people. Shifting cultivation is most extensively practiced in Africa but is also common in South America, Oceania, and Southeast Asia.¹ Shifting cultivation as a method of farming developed naturally in response to the need to produce food, but without the benefit of soil replenishment by commercial fertilizers, manure, or alluvial deposition.

Shifting cultivation was employed by North American pioneers during the 18th and 19th centuries. As farmers wore out the soil, they packed up and moved westward to virgin land. Eventually, the lack of new land, and improved land husbandry nearly eliminated shifting cultivation in North America. It is still practiced today, however, in dryland farming areas. Wheat growers in the dry areas east of the Rocky Mountains, where annual rainfall is 300 mm, fallow half their land in order to conserve moisture. This pattern of shifting cultivation is dictated by insufficient rainfall. The farmer annually shifts half his field from wheat to fallow, and the other half from fallow to wheat. During a field's fallow year, its groundwater is recharged.

Today, shifting agriculture is practiced mostly in the tropics. The shifting agriculture farming system and its variations are sometimes referred to as slash and burn, alternate husbandry, citemene system, bush fallow rotation, land rotation, recurrent cultivation, and swidden cultivation.

In returning fallow land to cultivation in traditional shifting agriculture, the bush is cleared of vegetation by the use of axes, knives, and fire. The land is then prepared for planting with a minimum of tillage. The hand hoe disturbs the soil very little. The surface soil is sometimes heaped into small

mounds, and several compatible plants, such as maize, yam, or okra, are planted in each mound. In other cases, an entire field will be planted to a single crop, such as maize. The cultivated crop will be weeded as long as this is no more laborious than clearing a new site.

The traditional shifting agriculture system does not result in excessive erosion because

1. the land is without vegetative cover only after a burn;
2. clearing is usually not done in unbroken tracts of land over an entire watershed;
3. the root systems, which are not consumed entirely by the burn, stabilize the surface; and
4. once the first crop is established, the soil remains fairly well covered.

It does appear that repeated cycles of cropping followed by fallow periods too short for the ecological balance of the system can result in severe erosion.

Rotations representative of those in use under shifting cultivation in equatorial Africa are shown in Table 3.1.

To determine the effect of shifting cultivation on soil, we must consider separately the systems in forests and in savannas (grasslands). Studies in equatorial Africa show that soil erosion is very low under forest fallow, a bit higher under grass fallow, and very high on cultivated land.

Organic matter in the soil increases during the fallow period, depending on the state of vegetative cover. It is estimated that in a typical forest regrowth, the annual production of litter and root materials can be as high as 6-8 t/ha. In grass fallow, the annual amount of plant material added to the soil does not exceed 1 t/ha, since the annual growth is less and the aerial parts of the vegetation are lost during the burns.

Table 3.1. Typical crop rotation for shifting cultivation.

Year	Rotation			
1	millet	maize	millet and legumes	maize
2	guinea maize	peanut	peanut	cassava
3	cassava	yam	millet and legumes	banana
4	6-10 yr of fallow	3-20 yr of fallow	millet and legumes	banana
5+			5 yr of fallow	3-10 yr of fallow

A study² in equatorial West Africa, found that in a forest fallow,

- more nutrients accumulate in standing vegetation than in soil—nitrogen increases annually by 60 kg/ha in the vegetation and by 30 kg/ha in the soil; and
- trees, with their deeper root penetration, are able to pump nutrients from the subsoil to the topsoil.

In a savanna fallow, the nitrogen increase is approximately 10 kg/ha per yr in soil and 25 kg/ha per yr in the vegetation.

When the population density exceeds 25 persons/km², population pressure tends to extend the cropping period and shorten the fallow period. This upsets the ecological balance of indigenous shifting cultivation systems, resulting in lower yields and soil degradation. Such a system is exploitative since more soil nutrients are removed than the system can replace. Because of overpopulation, the rational use of fertilizers and other forms of crop and soil management must be instituted if the food grown per capita is not to spiral downward to an inadequate level.

The land tenure system in Africa encourages shifting cultivation. The individual is frequently less inclined to make long-term agricultural improvement, since the land is owned by the entire community. Unlike farmland in North America, which is owned by an individual or corporation and can be used by the owner as he wishes, land in many parts of Africa where shifting cultivation is practiced is owned by the tribe and doled out by the chief and his advisors. Although this practice results in a fairly stable social system, the only investment in the farm is labor itself.

Land tenure favors certain types of agricultural systems. In North America, private ownership favors long-term investment in fertilizers, drainage systems and other investments to increase crop yield. In equatorial Africa, on the other hand, the land tenure system, which is part and parcel of the social system, encourages a shifting type of agriculture with little or no capital investment.

It is not easy to mechanize shifting cultivation as it is practiced in forest regions. New approaches must be explored. Mechanization in savannas is easier because there are not as many roots and stumps in the ground, and not as many trees to dodge. Minimal tillage, coupled with the rational use

of selective herbicides, is necessary to exploit the benefits of mechanization in forested areas. In addition, gradual selection and controlled tree cutting to permit the use of machinery in straight plots between a grid of permanent tree may prove beneficial. Shifting cultivation must employ elements of polyculture and agri-silviculture. Agri-silviculture is a system in which trees are planted and raised in combination with crops. In Myanmar (Burma), where the practice of raising trees with crops on the same land has been studied and reported, agri-silviculture is referred to as *taungya*.

Specific conditions allowed farmers even in prehistoric times to modify the microclimate and move from a system of shifting to permanent cultivation. The *chinampa* system in Mexico utilized muck from canals surrounding the fields as fertilizer for the fields. The muck, containing decaying organic matter and minerals, renewed essential nutrients and soil tilth. Meanwhile the canals controlled the water table in the fields. Along the shores of Lake Titicaca, a system of raised beds known as *camellones* was devised to counter flooding, drought, waterlogging, and frost damage. The raised beds ranged from 20 to 75 cm above the water, 4 to 10 m wide, and up to 50 m long, with canals between the beds. Lake Titicaca is in the tropics but at an altitude of 3803 m, so there are warm days but sometimes frost at night. The average seasonal lake level fluctuation is 60 cm, so the low-lying lake plain is often flooded. The raised beds surrounded by water modified the microclimate to reduce frost damage, while the height of the beds prevented waterlogging or flooding of the crops but ameliorated drought conditions so that potato, oca, and quinoa could be grown.³

3.3 Polyculture

Polyculture is a cropping system in which two or more useful plants are grown on the same land. Variations within the system are multiple cropping, mixed cropping, intercropping, relay planting, interplanting, and interculture.

Multiple cropping is the growing of more than one crop on the same land in 1 yr. For example, buckwheat may be planted after harvesting peas. Both crops are grown as monoculture crops, but they are planted and harvested within 1 yr.

Mixed cropping is the growing of two or more crops simultaneously and intermingled, with no row arrangement.

Intercropping is the growing of two or more crops in alternate rows, for example, maize alternating with soybean.

Relay planting is the practice of interplanting of the maturing crop with seeds or seedlings of the following crop, (If the flowering period of one crop overlaps that of the other, the practice is intercropping, not relay planting.)

Interplanting is the practice of planting a short-term annual crop with a long-term annual or biennial crop. Oats and alfalfa, for example, are commonly interplanted in the temperate zone.

Interculture is the cultivation of one crop underneath a perennial crop, such as rice under coconut palm.

Although polycultural practices were utilized to some extent in North America before World War II, mechanization and the advent of herbicides tended to favor monoculture. Polyculture is the dominant farming system in many areas of the tropics, where the degree of mechanization and the use of agricultural chemicals remain low.

It is more difficult to conduct experiments in a polycultural cropping system than in a monocultural system. One study makes the following observation.

What does emerge from a consideration of the literature, however, is the realization that most of the supposed advantages or disadvantages of polyculture are poorly documented. Experiments were generally run over a limited range of environmental and cultural variables and insufficient data are presented to conclude whether a specific mechanism was indeed operating. Adequate characterization of the soils in the experiments was also generally lacking.⁴

Polyculture is the typical farming system in traditional communities in the tropics. If the food output of these communities is to increase, the polycultural farming systems in use must be improved or altered. Polyculture provides a stability of yield that is crucial to many farming communities. Kass sums up the advantages and disadvantages.

. . . the literature generally indicates that polyculture is beneficial. However, the choice of crops and other environmental variables will, to a considerable extent, determine whether the practice is advantageous in specific situations. Assuming that the experimental work carried out thus far represents an adequate sample of the situations in which polyculture is practiced, it can nonetheless be concluded that definite advantages over

monoculture exist. In terms of withdrawal of nutrients from the soil, economic return, improvement of the nitrogen status of the soil-plant system when one of the crops is a legume, and greater stability of yields over time, the benefits of polyculture are clear. With regard to ease of harvest and other mechanized operations, polyculture offers some problems, but recent research aimed at reducing these difficulties has been surprisingly successful.⁵

This successful application of mechanization to polyculture was a system in Illinois, which had been mechanized before the polycultural system described (soybean and sorghum in oat) was instituted.

Mechanization of polycultural farming systems under shifting agriculture in the tropics is not accomplished easily. In fact, it is probably not economically possible to mechanize shifting cultivation unless other conditions affecting the agricultural system also change. An evaluation of farming systems in sub-Saharan Africa revealed that the movement of farmers from forest fallow to bush fallow to grass fallow to a permanent annual cropping system was due to economic incentives to produce more food. Successful mechanization using animal or tractor power did not occur before the grass fallow phase. The study made several other observations:

- Population growth and access to markets were the main determinant of agricultural intensification.
- The transition from the hand hoe to the animal-drawn plow was profitable only at higher farming intensities.
- It was not possible to use the tractor to accelerate the evolution of farming systems to permanent cultivation significantly.
- Lack of animal-husbandry or mechanical skills was only a short-run constraint to the use of animal or tractor power.
- High output prices accelerated the pace of intensification and mechanization provided that they were transmitted to the farm gate.⁶

3.4 Monoculture

Monoculture is a cropping system in which fields of single crops are cultivated. Although it is the predominant agricultural system in the temperate zone, monoculture is also practiced in large areas of the tropics. In general, it is easier to mechanize planting, pest management, and harvesting by growing one crop at a time. Furthermore, climatic and

economic factors often so favor a particular crop that there is little opportunity or financial advantage in a system other than monoculture. The wheat belt of North America and the irrigated ricelands of Southeast Asia are good examples of this phenomenon.

In monocultural farming system, one or more crops per year may be grown. For example, in North America there is only one annual maize crop, while in the Philippines there are often two rice crops. In both instances, the crops are grown under monocultural practices.

Monoculture lends itself to mechanization, since only one plant type is involved. Mechanization requires uniformity. The man with a hoe does not require straight and uniform rows, but a maize planter using a tractor requires an unobstructed field with uniform soil condition.

Although only one crop per year is grown in most monocultural systems, it is important for soil tilth that crops be rotated. Rotation refers to the practice of not growing the same crop in a given field every year. With the exception of the cultivation of wetland rice, rotation should be used whenever possible. Soil is a complex mixture of clay, silt, sand, and organic material in various stages of decomposition. By rotating crops, the farmer is able to improve soil structure, break insect and disease cycles, and improve fertility. A legume such as alfalfa is an ideal crop for rotation.

With the advent of pesticides and herbicides in the USA, many farmers grew maize year after year and found that, although the pesticide controlled the insects and weeds, the soil structure was slowly deteriorating.

The term "land equivalent ratio" (LER) is used to compare yields from different cropping systems. The LER reveals the number of hectares in a monocultural system required to produce the same amount produced by other cropping systems. For example, a polycultural system that interplants maize with peanut is compared with the monocultures of both crops.

$$\text{LER} = \frac{\text{wt maize/ha in maize - peanut system}}{\text{wt maize/ha in monoculture}} + \frac{\text{wt peanut/ha in a maize - peanut system}}{\text{wt peanut/ha in monoculture}}$$

The crop yield in weight per hectare (wt/ha) is usually used as the basis of comparison, but in calculating the LER, the basis of comparison can be energy, total digestible nutrients, dry matter, protein, or sales value.

3.5 Cropping calendars

“For everything there is a season, and a time for every matter, a time to be born, and a time to die; a time to plant, and a time to pluck up what is planted;...”⁷

Typical cropping calendars for Africa, Asia, and North America specify the time to perform particular operations for various crops (Fig. 3.1, 3.2). Since agriculture depends on the seasons, timeliness is very important for good crop yield.

3.6 Soil tilth and compaction

The condition—tilth-ofthe soil is of paramount importance to the farmer. Soil consists of solid particles separated by voids that are partially, or fully filled with water. The solid particles range in diameter from sand (0.02-2.0 mm) to silt (0.002-0.02 mm) to clay (< 0.002 mm).

3.1. Cropping calendar for Northern Region, Ghana.⁸

Soil moisture is at field capacity when the soil has reached equilibrium in drainage, in other words, when gravity has

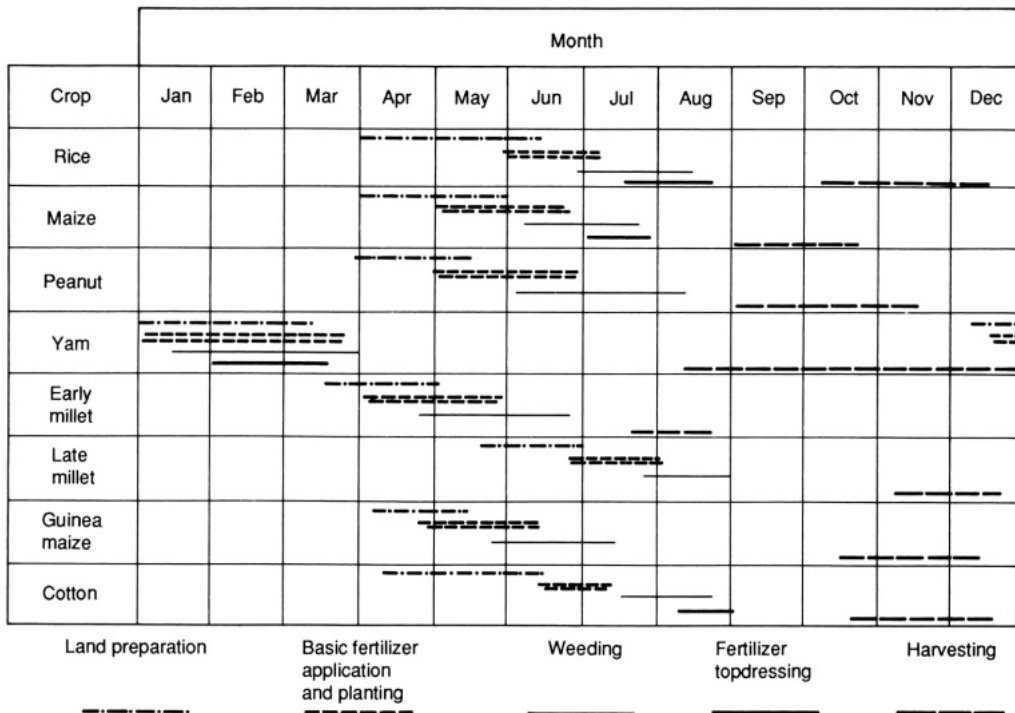

3.2. Cropping calendar for an irrigated rice scheme in Malaysia producing 2 rice crop/yr.⁹

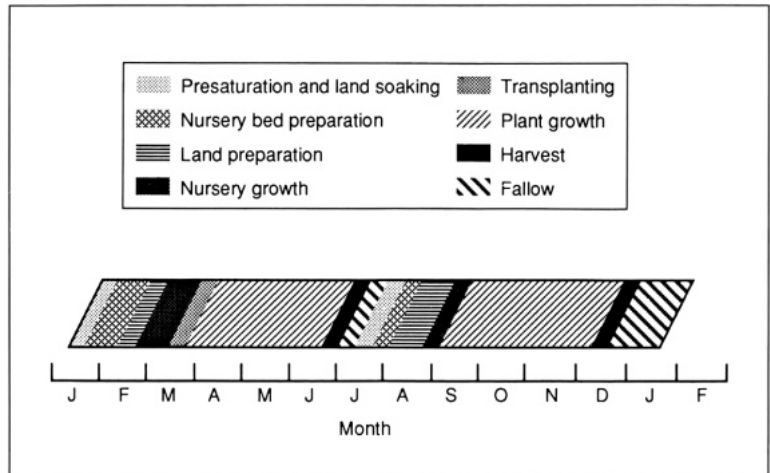

drained water from the large pores, but the small pores remain filled, since the capillary force holding the water is greater than the gravitational force attempting to drain it away. In an ideal soil for upland crops, about 50% of the volume is occupied by solids, 25% by air, and 25% by water.

Sandy and sandy-loam soils are coarse. More than half the volume is occupied by solids. The coarse texture provides a greater volume of large pores, so at field capacity over 25% of the soil volume is air and less than 25% is water. Because of the low water-holding capacity, sandy soils are said to be “droughty.”

Clay and clay-loam soils are fine textured; less than half the volume is occupied by solids. The fine texture provides many small pores, so at field capacity less than 25% of the volume is air and more than 25% is water. Because of the amount of water in the soil, clay soils warm up later in the spring, but are able to withstand droughty periods better than other soils.

Soil is waterlogged when its moisture content is greater than field capacity. A soil's wilting point is reached when the plant roots lose most of the water from the capillaries. Ideally, rainfall or irrigation keeps the soil moisture between the two conditions.

Tensiometers are instruments that provide readings on soil moisture. A tensiometer usually consists of a vertical piece of small-diameter tubing with a porous ceramic cup at the bottom and a vacuum gauge at the top. The tube is filled

with water, and the bottom is placed in the root zone (or at the soil depth at which information is required about soil moisture). A tensiometer ceases to function when air enters it. In sandy soil, a tensiometer performs well over moisture levels representing about 90% of the available water, while in clay soil it records levels to about 50% of available water.

The weight of a cubic meter of dry sandy soil is greater than that of a cubic meter of dry clay soil, yet farmers refer to sandy soil a “light” and to clay soil as “heavy.” This is because fine-textured soil such as clay is more difficult to work and requires greater energy to cultivate than does a coarse-textured soil such as sand. Farmers usually prefer soil that combines sand, silt, and clay, such as sandy loam or silty loam.

Because of variations in soil, climate, moisture, and crop, tillage must be tailored to the situation to assure optimal soil tilth and long-term crop production. Experiments in light and heavy soils under semiarid rainfed conditions in Botswana and Sudan provide information concerning tillage requirements in relation to soil type. The Botswana soil was a ferruginous sandy loam classified as Luvisols/Cambisols. Its water-holding capacity was low, and because of soil structure, heavy rainfall, and intense sunlight, crusting of the soil surface was common.¹⁰ Crusting inhibits water infiltration and contributes to runoff and erosion. In contrast, the Sudan soil was a black cotton montmorillonitic clay soil classified as a Vertisol. This soil is sticky when wet and cloddy when dry. During the dry season, the soil shrinks, and deep cracks into which a hand can be inserted appear. Dust and soil particles fall into the cracks. When rain falls, water and surface material are washed into the cracks, the montmorillonitic clay expands, and the material in the cracks mixes with deeper soil.

A moldboard plow, a chisel plow, a one-way disc harrow, and a shallow sweep were all used in the tillage experiments. The crop was sorghum. In the Luvisols of semiarid Botswana, the roots were confined to the depth of tillage, and the yield was directly correlated with the depth of primary tillage. Soil tilled with the moldboard plow lost the most moisture, and planting depended on subsequent rainfall. Both moldboard and chisel plows increased soil porosity to acceptable levels. but the porosity was reduced by the compaction that occurred while preparing the seedbed during secondary

tillage. A chisel plow or a one-way disc harrow was necessary to loosen the root zone in compacted sandy Luvisols.

In the black cotton clay Vertisols in Sudan, the root system was not confined to the depth of primary tillage, and there were no significant differences between the yields of sorghum or cotton at the various tillage depths. Only shallow cultivation with a one-way disc harrow or application of a herbicide to suppress weeds before planting was necessary. This is fortunate, since plowing black cotton clay requires much power and produces many clod, which must be pulverized to form a seedbed.

Because the roots of upland crops require oxygen from the soil, approximately 20% of soil volume must be air space. Plant growth is retarded if soil air space is reduced to below 10-15%.

In wetland rice production, conditions are quite different. No oxygen is required in the root zone, because the plant has the ability to ingest oxygen through the leaves and transport it to the roots. Rice is grown in standing water as a method of weed control and to reduce the power required for manual and animal tillage. Also, the crop does not suffer from lack of water. Thus a ricefield does not require soil porosity. On the contrary, soil particles are made fine by puddling so that water will not percolate down through the bottom of the field and be wasted.

Since the size of the pores and capillaries between the solid particles of soil determines its water-holding and root penetration characteristics, soil compaction by animals or machines alters the soil's physical characteristics. Internal forces such as freezing, drying, and swelling, and external forces such as rain, animals, vehicles, and tillage tools alter the number and size of the pores.

The hooves of horses and cattle exert a pressure of approximately 48 psi (331 kPa) on the soil; humans, 28 psi (193 kPa); sheep, 18 psi (124 kPa); and farm tractors, about 10 psi (69 kPa). Although it appears that humans and animals are a greater cause of soil compaction than farm tractors are, the depth of soil compaction depends on the total weight of the animal or vehicle as well as on the soil moisture. The degree of soil compaction can be visualized as isopressure lines plotted as pressure bulbs, as in Figure 3.3.

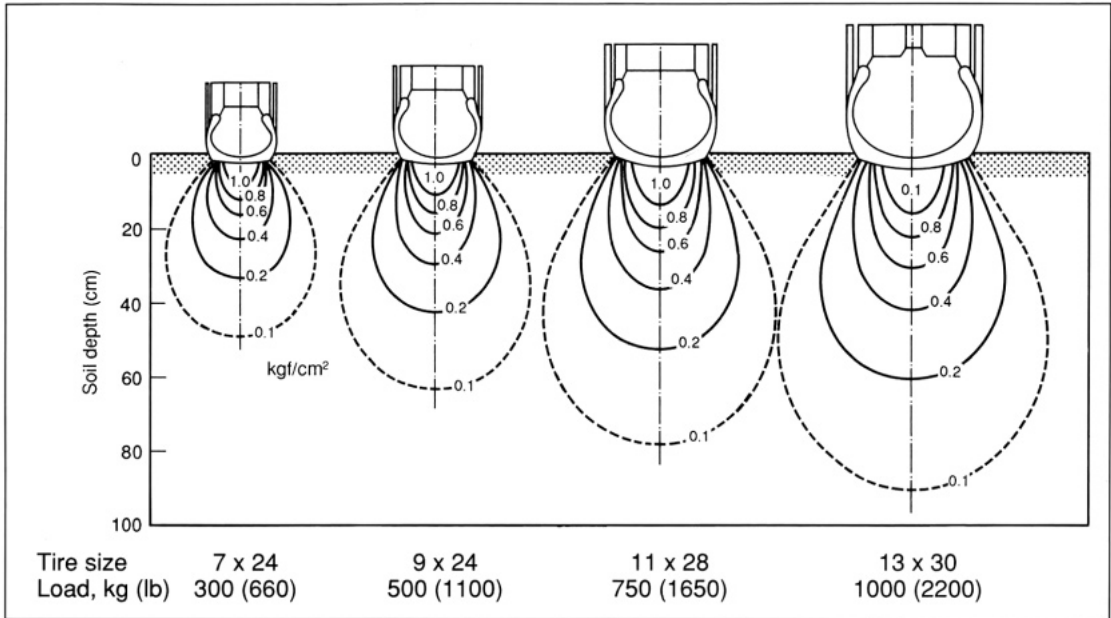

3.3. Isopressure lines under pneumatic tractor tire.¹¹

Figure 3.3 illustrates a study¹² of how heavy wheel loads increase the depth of compaction even though the tire pressure remains constant and the soil is at normal desirable field moisture and density. The tire dimensions were chosen according to the load so that the soil contact areas were proportional to the wheel load; thus, with all tires at an equal tire inflation pressure of 0.84 atmosphere (85.1 kPa, 12.3 psig), pressure distributions at the tire-soil contact areas were assumed to be similar. In a hard dry soil, the 0.1 kg/cm² isopressure line under the 11 x 28 tire would be about 13 cm shallower, while for a wet soil it would be about 10 cm deeper than in the normal soil shown in Figure 3.3.

Soil compaction can be useful or detrimental, but it is usually the latter. In general, compacting the soil reduces the number of larger pores and increases the number of smaller pores, with the result that the soil loses drainage capacity and remains wet for a longer period after rains. A wet soil is usually a cold soil. Because of the high specific heat of water, more heat is required to warm wet soil than dry soil. In the temperate zone, this phenomenon can be noted in the spring, when the soil is warmed by bright sun and longer days. Seed germination and plant growth are delayed in wet soils.

Common methods for improving wet soils for upland crops are installing subsurface tile drainage, growing crops on mounds or ridges, staying off the soil when it is wet, replacing wheel tractors with tracklayers, and crop rotations that improve soil drainage.

The effect of soil compaction on soil moisture and crop yield was demonstrated at MacDonald College in Ontario, Canada, in 1976 and 1977. The experiments were conducted on clay soil prepared by fall plowing followed by spring rototilling to a depth of about 25 cm. The soil was then compacted using 3 tractors with weights of 1700, 3515, and 4420 kg (3750, 7750, and 9750 lb) making 0-15 passes either before or after the planting of silage maize.¹³

The year 1976 was wet, with 16-20 cm more rain than normal during the main growing season in June and July. The harvest revealed that the least dense soil (no tractor traffic) gave the best yield, while the densest soil (15 tractor passes) had about half the yield. In contrast, 1977 was dry, with 8-10 cm less rain than normal during the main growing season. This time, the plots with a moderate amount of compaction produced the best yield. In 1976 the problem was drainage, not water storage, so large pores were an advantage. In 1977 the problem was water storage, so small pores—created by compressing large pores—were an advantage.¹⁴

Slippage of a tractor's drive tires is an important cause of compaction. A tractor tire running in a furrow and slipping clings to the load it is pulling smears the soil surface and squeezes out the voids below the bottom of the furrow. Plows and disks working in wet soils with a high percentage of clay also smear the soil at the bottom of their working depth. The result is a thin, impervious layer called a plow sole. Soil compaction is greatest when tractor drive wheel slippage is between 15 and 25%. Above 25% slip, the tires throw soil off to the sides, causing deep ruts.

The technique of tramlining or controlled traffic farming reduces soil compaction in the plant row, while increasing it where the tractor wheels run between the rows. The first trip of the tractor across the field produces 70-90% of the total compaction. In a small grain crop such as wheat, grain is not planted in the rows where the tractors run. The wheels run in the open rows so that the root zone is not compacted. Ridge planting can also be used to control compaction. By keeping

the ridges in the same locations over a period of years, the soil under cultivation is never compacted.

Cable systems wherein the implements are pulled across the field by cables attached to a winch are occasionally used in research because they reduce compaction normally caused by tractors.

A large 15-t wheel tractor may minimize soil compaction because it makes fewer trips across a field than a smaller tractor. If the large tractor is used when the soil is too wet, however, deep compaction will result and adversely affect crop yields for years. This is unfortunate, because a large tractor pulling a tillage tool made for a smaller tractor can operate in a wet field when soil conditions would prevent the use of the same tillage tool behind a small tractor. Much of the soil damage attributed to large tractors is due to tilling when the soil is too wet.

The best tillage system cannot be determined by any hard and fast rule. Wide variations in soils, temperature, rainfall patterns, and crops demand that tillage be modified to fit specific conditions. Frequently, the type of soil manipulation must be varied from field to field on the same farm.

REFERENCES CITED

1. Food and Agriculture Organization (1974) Shifting cultivation and soil conservation in Africa. Soils Bulletin 24. Paper presented at the FAO/SIDA/ARCN Seminar, Jul 1973, Ibadan, Nigeria.
2. Ibid.
3. Erickson C L (1985). Applications of prehistoric Andean technology: experiments in raised field agriculture, Huatta, Lake Titicaca: 1981-1982. Pages 209-212 *in* Prehistoric agriculture in the tropics. BAR International Series 232. I.S. Farrington, ed. Oxford, England.
4. Kass D L (1978) Polyculture cropping systems: review and analysis. Cornell International Agricultural Bulletin 32. Ithaca, New York.
5. Ibid. p. 55.
6. Pingali P, Bigot Y, Binswanger H P (1987) Agricultural mechanization and the evolution of farming system in sub-Saharan Africa. The John Hopkins University Press, Baltimore.
7. Holy Bible (1952) Ecclesiastes, Chapter 3; Old Testament. Revised standard version. Thomas Nelson & Sons Publishers, New York.
8. Ghanian-German Agricultural Development Project - Northern and Upper Regions (1977) Agricultural extension handbook, 1977. Tamale, Ghana.

9. Thavaraj S H (1978) The importance of integrating nonengineering aspects in irrigation system design. Pages 15-24 *in* Irrigation policy and management in Southeast Asia. International Rice Research Institute, P.O. Box 933, Manila, Philippines.
10. Willcocks TJ (1984) Tillage requirements in relation to soil type in semi-arid rainfed agriculture. *J Agric. Eng. Res.* 30:227-336.
11. Sohne W (1953) Druckverteilung im Boden Und Bodenverformung Unter Schepperreifen (Distribution of pressure in soil and soil deformation under tractor tires). *Grundlagen Der Landtechnik*, Heft 5. p. 51
12. *Ibid.*, p. 49-63.
13. Raghavan G S V, Mckyes E, Gendron G, Borglum B K, Le H H (1978) Effects of tire contact pressure on corn yield. *Can. Agric. Eng.* 20 (1)34-37.
14. McKyes E (1980) Field traffic impact on soil compaction. *Cornell Agricultural Engineering Extension Bulletin* 449. Proceedings of a seminar on the influence of tillage practices on crop growth. Department of Agricultural Engineering, Cornell University, Ithaca, New York.

BIBLIOGRAPHY

- Drache H M (1964) The day of the bonanza. North Dakota Institute. for Regional Studies, Fargo
- Jurion F, Henry J (1969) Can primitive farming be modernized? [translated from French by Agra Europa]. Wellens-pay. s.a., Bruxelles. Belgium. Publications de l'Institut National pour l'Etude Agronomique du Congo.
- Kamarck A M (1976) The tropics and economic development. The Johns Hopkins University Press, Baltimore.
- Kuipers H (1984) The challenge of soil cultivations and soil water problems. *J. Agric. Eng. Res.* 29:177-190.
- Morling R W (1982) The pros and cons of controlled traffic farming. Paper 82-1043. American Society of Agricultural Engineers, St. Joseph, Michigan.
- Schafer R L, Johnson C E, Elkins C B, Hendrick J G (1958) Prescription tillage: the concept and examples. *J. Agric. Eng. Res.* 32:123-129
- Wijewardene R (1978) Systems and energy in tropical farming. Paper 78-1511. American Society of Agricultural Engineers, St. Joseph. Michigan.
- Wijewardene R (1981) Techniques and tools, conservation farming for small farmers in the humid tropics. International Institute of Tropical Agriculture Sri Lanka Program, Colombo.

4 Tillage

Tillage is the manipulation of soil to obtain favorable conditions for plant growth. Good tillage provides a proper seedbed. For example, a lettuce seed requires a seedbed consisting of fine particles, since the seed itself is very small. Weed control is also obtained through tillage by turning the weeds under the soil with a moldboard plow before planting a new crop. After depositing the weeds 15 cm below the surface, the seeds of the newly planted crop can germinate and grow without competition for sunlight, water, and nutrients. The weeds will return, but by that time the crop will be large enough to compete.

Organic matter from weeds, crop residues, or green manure creates better soil tilth. Decomposing organic matter also improves soil fertility.

Tillage is also used to provide the desired contour for certain crops. For example, a specific type of plow, called a ridger is used to form ridges on which peanuts are planted. In irrigated rice production, tillage practices keep the field level and prevent the loss of water.

Tillage practices are determined by the type of soil, crop, topography, and available power.

4.1 Tillage tool classification

Tillage tools may be classified according to

- condition of seedbed
 - primary
 - secondary
- disposition of surface debris
 - inverted (trash buried)
 - not inverted (trash on surface)

- power source
 - human-powered
 - animal-drawn
 - tractor-powered

Soil is not prepared for seeding or transplanting in a single operation in most farming systems. Instead, a rough form of tillage such as plowing is first accomplished. This operation is called primary tillage. Secondary tillage refers to smoothing the rough condition of the soil surface into a seedbed. The primary and secondary tillage phases are combined when using a powered rotary tiller because the action of the tines can produce a finished seedbed in one pass.

Primary tillage tools that *do not* invert the soil are the hoe, ard, chisel plow, and subsoiler.

Primary tillage tools that *do* invert the soil are the spade, moldboard plow, disc plow, rotary tiller, and rotary spading machine.

4.2 Hoes

The hoe used for primary tillage in many parts of the world is quite different from the long-handled, lightweight hoe familiar to the North American or European gardener. The digging hoe shown in Figure 4.1 weighs about 4 kg. It has a short, stout, wooden handle about 1 m in length and a steel blade approximately 10 cm wide by 30 cm long. The angle between the handle and the blade is approximately 60°.

Hoes differ according to the size of the blade, the angle between the handle and blade, and the method of attaching the handle to the blade. Some primitive blades are made from wood, but today this is uncommon, since scrap metal or manufactured blades are available in most parts of the world.

4.1. Digging hoe.

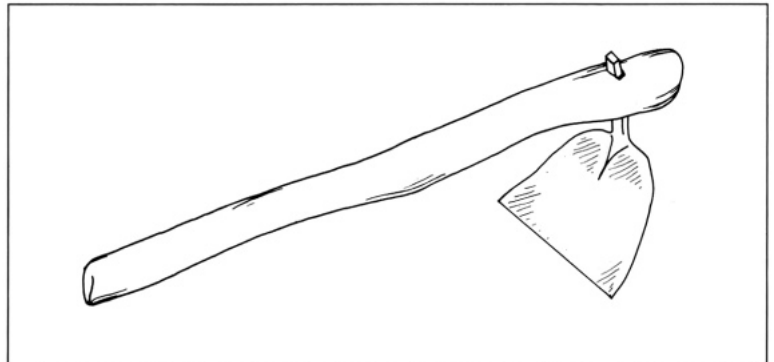

The best blades are made of forged and heat-treated steel, and have a D-shaped eye through which the wooden handle is securely wedged.

Some hoe blades are affixed to the digging hoe handle by a spike welded to the, top of the blade. The blades of primitive hoes are lashed to the handle with cord. These two types of blades are satisfactory for light work such as weeding, but not for primary cultivation.

Digging hoes have short handles because they are used for heavy work and demand the expenditure of considerable force. If the handle were longer so the farmer need not stoop, it would have to be much stouter (and heavier) to avoid breakage. The digging hoe is the product of many generations of development, and usually reflects the best design possible under the constraints of available materials, manufacturing facilities, farming practices, cost, and power of the user. It is extremely difficult for an engineer to improve a locally made hoe without increasing the cost to a greater degree than the improvement. One example of hoe improvement is where West African blacksmiths changed from mild (low carbon) steel scrap to leaf springs from wrecked trucks. Truck springs are made from high carbon steel, which can be heat-treated to obtain a durable cutting edge and greater strength.

Hoes show great variance in width and in the angle between the blade and the handle.¹ For example, a hoe for use in a ricefield has a wider blade than one used on hard, dry upland soil. The angle between handle and blade in the hoe used to build ricefield banks (bunds) differs from that in the hoe used for tilling the field.

Preparing dry soil to a depth of 10-15 cm with a digging hoe requires approximately 300 man-hours per hectare (man-h/ha), while 100-200 man-h/ha are required to complete primary tillage in flooded soil.²

4.3 Spades and shovels

Spades and shovels are used to dig, lift, and invert soil to prepare a seedbed. They are also used to dig postholes and ditches. Although spades and shovels are commonly used in North America for tilling home vegetable gardens, they are not used for land preparation in LDCs. Since the common spade or shovel requires foot pressure when spading earth, the user must wear a pair of stout shoes, unless the tool is constructed with a broad footrest to make it usable with bare feet.

The blade of a spade has little curvature and is rectangular in shape. The handle is about 70 cm long, and the grip is either D- or T-shaped. The D-shaped top with a pressed steel retainer holding a hardwood grip is the most satisfactory for strength and comfort (Fig. 4.2).

The long-handled shovel (Fig. 4.3) is about 150 cm long. It has a pointed, curved blade approximately 22 cm wide at the head and 30 cm long. The handle's diameter tapers from 4 cm at the blade to 3 cm at the end. Such a shovel weighs approximately 2 kg.

4.2. Spade with a D-shaped hand grip.

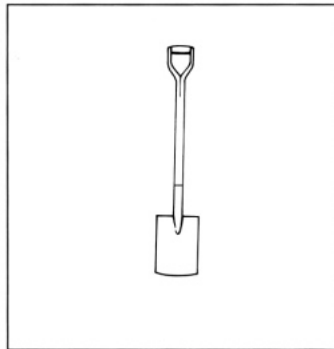

4.3. Pointed shovel.

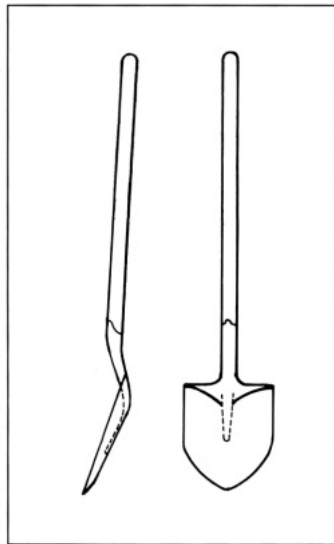

4.4. Foot plow (chaquitaqlla) (far right).

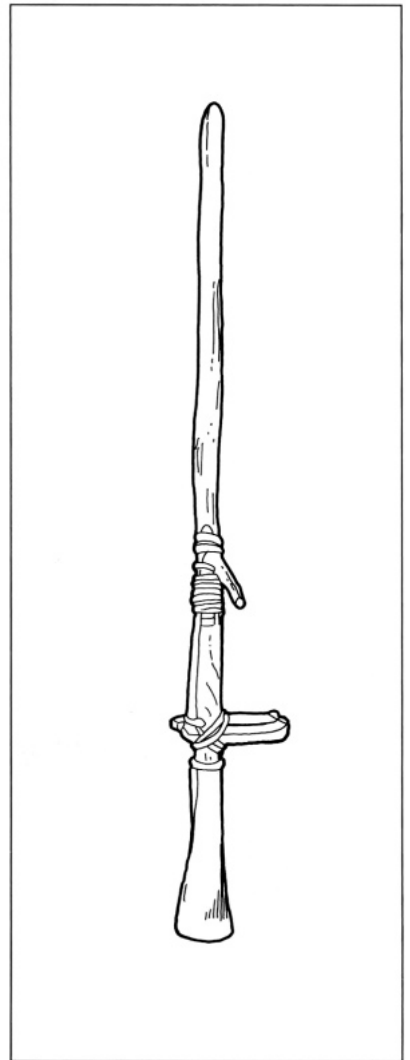

4.4 Foot plows

The foot plow or chaquitaqlla, also called a rhuki or shuki, is indigenous to the Andean region, where it was developed 1300 to 2500 yr ago.³ It is still used in Peru, Bolivia, and the mountainous regions of neighboring Andean countries. Steep slopes are farmed in the Andes using a fallow system of agriculture. The foot plow, shown in Figure 4.4, is a tool made from local materials, it is designed to enable farmers to invert sod at the end of the fallow period and to do other tasks as well. The foot plow is used more like a pry bar than a shovel.

The first chaquitaqlla was probably a pointed pole with an attached footrest. Today, a typical foot plow is 1.45 m long, with a pole diameter of 7 cm and a blade 13 cm wide. The foot plow consists of four parts: wooden pole, handhold, footrest, and metal blade. The wooden handhold is fastened to the pole with the rope that supports the footrest. Sometimes the handhold is a projection from the pole, which is often fashioned from a natural branch on the tree from which the pole is cut. The footrest is a wooden step attached to the pole by leather thongs. A braided rope, usually of llama hair, secures the footrest to the handhold. The rope prevents the footrest from slipping on the pole and provides adjustment to suit the farmer. The steel blade (Fig. 4.5) fastened to the bottom end of the pole is usually fabricated from automobile or truck leaf spring. The cutting edge of the blade varies according to the soil. In stony soils, the blade is narrow and pointed; in stone-free soils, the blade flairs like an ax head.

A typical use of the foot plow is to prepare the soil for planting potato on steep slopes at 3,000-4,000 m altitude. Potatoes are planted in rows that either run vertically down

4.5. Chaquitaqlla blades.

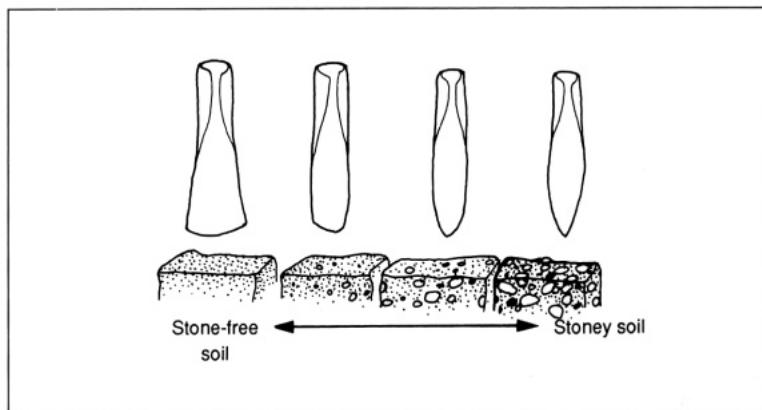

4.6. Potato seedbed prepared by a chaquitaqlla.

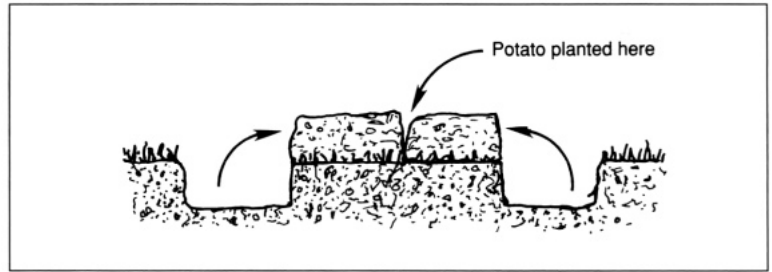

the slope or are arranged in a herringbone pattern. Working with a foot plow on a steep slope is easier if one begins at the top and works downward. Generally, several farmers work together. Potatoes are planted in the slots created by abutting pieces of sod, as depicted in Figure 4.6.

4.5 Ards

Ards, chisel plows, field cultivators and subsoilers belong to a group of tillage implements that do not invert the soil. Most of the crop residue and clods remain exposed on the surface of fields tilled with ards.

The ard is a single-point chisel plow and is sometimes called a breaking plow. Sumerians used ards around 3600 BC. Animal-drawn ards are still used today in many areas of the world. The ard is used primarily for shallow tillage in semiarid areas. Since the ard does not invert the soil and leaves a layer of trash on the surface, it helps to alleviate the effects of wind erosion.

Ards can be categorized into two major groups (body ards and beam ards) and three minor groups (sole ards, triangular ards, and quadrangular ards).⁴ Figures 4.7-4.10 illustrate four common ards in use today.

In the body ard, the body which is composed of a soil engaging point and a handle) is pierced by the beam. In the

4.7. Body ard (India).

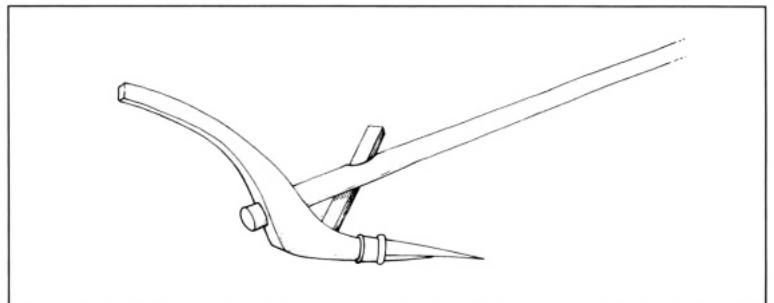

4.8. Beam ard (Ethiopia).

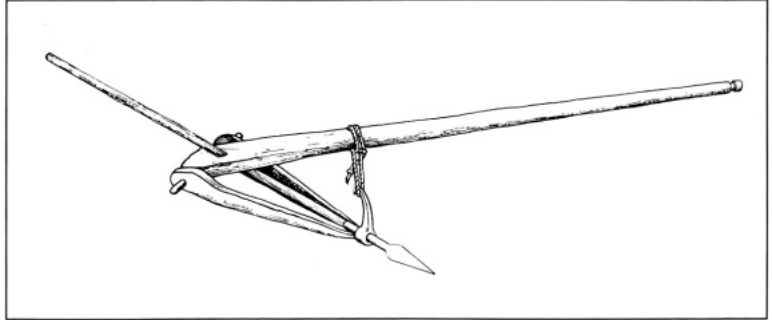

4.9. Sole ard (Peru).

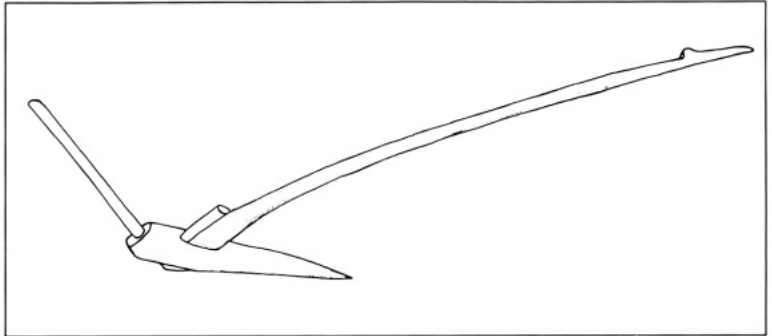
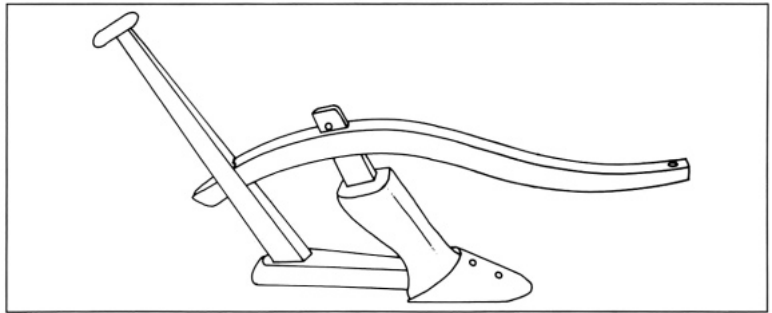
4.10. Quadrangular ard (China).⁵

beam ard, the beam is pierced by the body. The sole ard features a horizontal sole and point to which the beam and the handle are attached. It probably evolved from the body ard. Various modifications of the basic beam and body ards evolved to improve plow strength or better fit local agricultural conditions. Triangular ards were developed in some countries to provide stronger, more rigid implements. The quadrangular ard has a horizontal sole with the beam parallel to the ground and the handle nearly perpendicular.

Ards are generally made of wood, except for a steel share point. To steer an ard, the handle is moved opposite to the

desired direction of travel. Depth adjustment is made by changing the angle between the beam and the body. This is accomplished by hitching the beam closer to or further away from the yoke, by extending or retracting the share tip in relation to the point, or by altering the position of a wedge or pin.

A typical ard weighs about 15 kg. Examination of ards and ox yokes in Ethiopia revealed that an ard and shoulder yoke for 2 oxen had a total weight of 20 kg, which is light enough for the farmer to carry both implements to the field.

Experiments were conducted in northern Jutland in 1962-68 with a replica of a beam ard of 350 BC. Two Jersey oxen were utilized as draft animals. Tests were carried out on 18-month-old grassland on sandy soil. The grass was cut and removed before plowing. With the share tip 10 cm ahead of the ard head, plowing depth was 12.6 cm. When the share tip was 20 cm ahead of the point of the ard head, plowing depth was increased to 15.4 cm. The 15.4 cm depth did not result in broader furrows or better soil preparation. Furrow width was approximately 10 cm. Speed of plowing was 4 km/h with an average draft of 100 kgf (0.98 kN, 220 lb) and peaks of 150 kgf (1.5 kN, 330 lb). Drawbar horsepower was 1.5.⁶

One plowing with an ard is usually insufficient to prepare a seedbed. From two to six passes may be required, depending upon the vegetation in the field at the time of plowing and the type of seed to be sown. Heavy sod in a field that has been fallow for a number of years or land preparation for a seedbed for small seeds will necessitate perhaps four or five trips across the field; a field with a friable soil and a light stubble such as bean stubble, or land preparation for large seeds such as maize or beans will require only two or three trips across the field. When preparing a field, each successive plowing is done at an angle to the previous trips across the field. For example, the second plowing may be done at 40°, the third at 150°, and the fourth at 90° to the first.

Through time the body ard developed into the moldboard plow.

4.6 Chisel plows

The tractor-drawn chisel plow (Fig. 4.11) is a primary tillage implement with a working depth of 10-30 cm. It is a modern version of the ard. Since the chisel plow, unlike the moldboard plow, does not expend energy inverting the soil,

4.11. Chisel plow.



Illustration courtesy of Deere & Company

it requires less energy per unit of width tilled. Furthermore, the back furrows and dead furrows associated with moldboard plows are eliminated.

A chisel plow consists of a number of shanks attached to lateral tool bars, which form the frame. The vertical clearance from the frame to the chisel point varies from 55 to 80 cm. Sufficient distance between frame and soil is essential for trash clearance. Mounted chisel plows are available in widths ranging from 1.5 to 6 m wide. Trailing chisel plows are 2.5 to 14 m wide.

Chisel plows are usually either two- or three-bar units. Since normal shank spacing is 1 shank per 30 cm (1 ft) of width, a 2-bar frame must have a shank every 60 cm, while the shanks on a 3-bar frame are spaced every 90 cm. The three-bar unit thus provides more space for trash movement. The typical chisel plow shank is a curved piece of spring steel with a cross section of 2.5 x 5 cm for a regular shank and 3 x 5 cm for a heavy-duty shank. Shanks are identified by cross section and clearance. Typical shank clearances are 20, 25, and 30 in (55, 65, and 80 cm). The shank is secured to the frame by a rigid mounting for use in rock-free soil. In rocky soil, shanks are mounted to the frame by the more expensive spring cushioned clamps.

Shovels, sweeps, or spikes are mounted on the shanks. Reversible shovels 5 cm wide are the most common. Power requirements are less for shovels than for sweeps or twisted shovels. A twisted shovel is used to turn earth and trash aside,

mix more of the trash into the soil, and leave a rougher soil surface. Both right-hand and left-hand twisted shovels are available.

Sweeps are used primarily for weed control. Working depth is usually shallow—approximately 10 cm. Depth is controlled by gauge wheels.

In the semiarid regions of the U.S., where a summer fallow is customary, a chisel plow or field cultivator equipped with wide sweeps is often referred to as a duckfoot cultivator.

The main frame of a chisel plow should be parallel to the ground so all teeth work at the same depth. Working speed is 7-10 km/h. Higher speeds help to alleviate plugging in heavy trash conditions. If proper ground speed cannot be maintained while working at the desired depth, two passes are made. The first pass is shallow. The second pass is at an angle to the first pass and at the desired depth.

The horsepower values in Table 4.1 are approximate for chisel plows equipped with 5-cm-wide (2 in) shovels. The table assumes that the tractor's maximum drawbar horsepower is 75% of the maximum PTO horsepower. Power requirements vary when using twisted shovels or sweep.

In general, a chisel plow requires 1/3 to 1/2 the power required by a moldboard plow for the same depth, width of tillage, and speed. The moldboard uses more power because it inverts all of the soil, while the chisel does not disturb all the soil, nor does it invert the soil. Chisel plows have become popular in continuous maize production systems using herbicides. Before herbicides were available, the moldboard plow was often required to bury weeds so as to give seedlings a headstart. With the advent of herbicides, however, the chisel plow's lower power requirement made it more practical.

Table 4.1. Tractor requirements for a chisel plow (tractor PTO hp/shank).

Depth in cm (in)	Speed in km/h (mph)	PTO hp/shank		
		Sandy loam	Loam	Clay
15 (6)	8 (5)	3.0	6	10
20 (8)	8 (5)	4.5	8	14
25 (10)	8 (5)	5.5	10	17
30 (12)	8 (5)	6.5	12	20.5

4.7 Field cultivators

A field cultivator is difficult to distinguish from a chisel plow. Essentially, it is a lightweight chisel plow with closer shank spacing and less vertical clearance. It is a secondary tillage tool. Mounted field cultivators range from 2.4 to 7.3 m (8 to 24 ft) in width, while trailing models range from 2.4 to 18 m (8 to 60 ft). They are manufactured in both two-bar and three-bar frames. As with the chisel plow, three-bar frames provide more clearance than two-bar frames. Field cultivator shanks are mounted to provide 15- to 25-cm (6- to 10- in) spacing. Shanks may be either rigidly mounted or spring mounted. Sweeps, shovels, and points are similar to those on chisel plows. The usual working depth for a field cultivator is 8-13 cm. Power requirements are given in Table 4.2.

4.8 Subsoilers

A subsoiler is a chisel plow designed to work at a depth of 50 cm (18 in). Common subsoilers have maximum plowing depths of 40-60 cm (15 to 24 in). Plowing at that depth requires a very rugged chisel and considerable power. The main reason for using a subsoiler is to break the hardpan for better moisture control. In some dry soils, it is possible to crack the earth to a depth of 60 cm on each side of the point of the subsoiler chisel.

Subsoilers are usually tractor-mounted units with one to nine chisels. Some units can be attached at adjustable spacing on two bars. A popular 9-shank unit has 55-cm (21-in) spacing between shanks. Some subsoilers with multiple shanks have automatic trip mechanisms. Each shank is free to trip independently of the others whenever an obstruction is encountered. As soon as the obstruction is passed, the shank automatically returns to working depth. On multiple shank subsoilers, gauge wheels are used to maintain depth of penetration.

Moles and pipe and cable laying attachments are available for many units. Subsoilers are not beneficial under all soil

Table 4.2. Tractor requirements for a field cultivator (tractor PTO hp/shank).

Depth in cm (in)	Speed in km/h (mph)	PTO hp/shank		
		Sandy loam	Loam	Clay
13 (5)	8 (5)	2.7	3.7	5

conditions. For example, when water under pressure underlays an impermeable layer of subsoil, subsoiling can fracture the layer and result in a wet field. Dry, clayey soils receive more benefit from subsoiling than do wet or sandy soils. The subsoiler's power requirements are given in Table 4.3.

Subsoilers are usually classified by the type of shank. The vertical, parabolic, and 45° leg are the most common (Fig. 4.12).

The Howard Paraplow™ is a 45° leg subsoiler that has an adjustable shatter plate so that the degree of fracture can be adjusted to soil and power conditions. A vertical tine moving through the soil creates fracture lines radiating out at 45° angles from the tine. The Paraplow™ utilizes this soil characteristic by situating the plow point and the landside at the bottom end of the shin. An adjustable, rudder-like shatter plate, which comprises the leading and trailing edges of the 45° portion of the leg, is also fitted to the shin. The cross section of the shin, leg, and shatter plate assembly resembles an airfoil. As the soil flows over the upper surface of the foil, it is subjected to tension and cracks. If the soil is too plastic to fracture, the shatter plate can be adjusted to force the soil to greater tensile stress so that it will fracture. Producing greater stress requires increased energy, and thus increased tractor horsepower.

The Paraplow™ is a right-hand machine like a moldboard plow and should be worked at a speed of 3-5 mph (5-8 km/h). It cannot be worked from one side of a field to the other like the other types of subsoilers or chisel plows and field cultivators.

The tractor wheels must be set so that the tires do not run over the finished work and compact the loosened soil. For the maximum working depth, the legs are set on 20-in (50-cm) spacings.

Table 4.3. Tractor requirements for a subsoiler (tractor PTO hp/shank).

Depth in cm (in)	Speed in km/h (mph)	PTO hp/shank	
		Loam	Clay
30 (12)	6.5 (4)	17	25
45 (18)	6.5 (4)	26	38
60 (24)	6.5 (4)	35	50

4.12. Types of subsoilers.

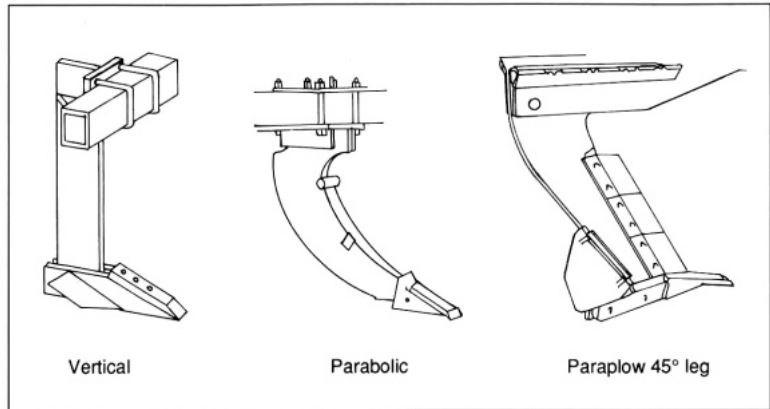

When beginning work in a field, the shatter plate should be set for the least protrusion above the leg. If soil fracturing is not satisfactory, the angle of the shatter plate to the leg should be increased until it is. The ParaplowTM is designed to work at a maximum depth of 14 in (36 cm).

4.9 Moldboard plows

The primary advantage of the moldboard plow is that it does an excellent job of inverting the soil and burying surface trash. The moldboard plow can be visualized as two wedges. The share, landside, and moldboard form the wedges. A moldboard plow viewed from the side resembles a wedge formed by the share and the moldboard. This wedge cuts and lifts the furrow slice. Viewed from the top, the plow looks like a wedge formed by the landside, share, and moldboard. This wedge moves the furrow slice to the side while simultaneously inverting it.

Figure 4.13 shows the parts of a plow bottom. Moldboard plows are made largely of mild steel. The share, however, is usually made from a special alloy or laminated steel. The moldboard is fabricated from an alloy steel with good scouring properties. Cast iron is satisfactory for shares and moldboard if the plow is used in conditions free of stones or other obstructions; however, few tractor plows are made of it today. Occasionally, moldboards are made of fiberglass.

Moldboard plows, when properly adjusted, automatically seek the designated depth. It is unnecessary to add weight to a moldboard plow to penetrate the soil to the desired depth.

The plowshare is designed to provide down suction and side suction. Down suction causes the plow bottom to

4.13. Moldboard plow nomenclature.

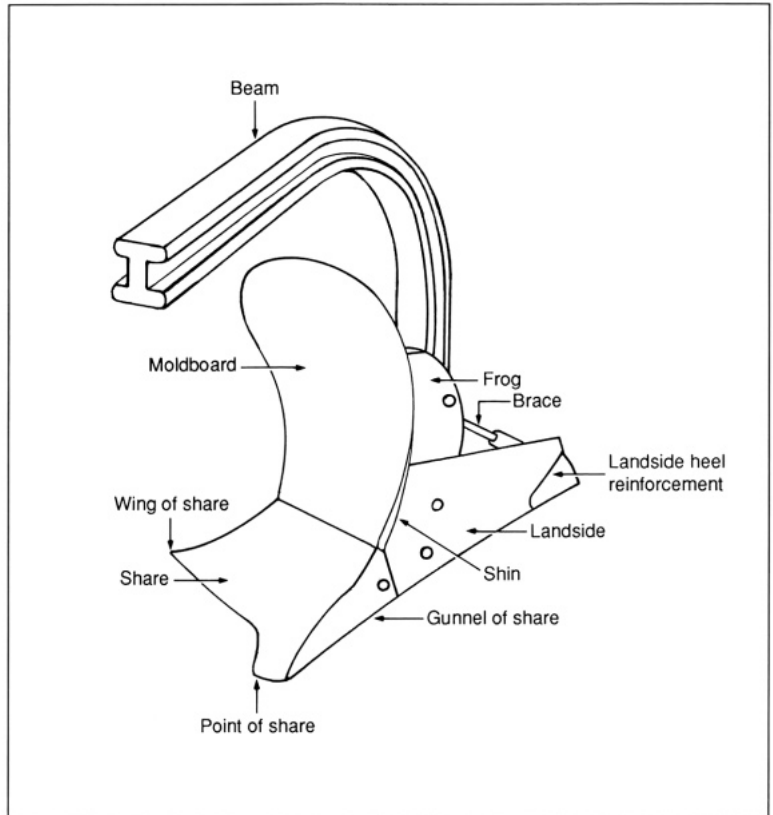

penetrate the soil, while side suction holds the plow to an even full-width furrow. Too much down suction makes it difficult to control plowing depth, while too little down suction causes the plow to run too shallow. Too little down suction is more common than too much. Too little side suction allows the plow to weave, making it difficult to plow a straight furrow. Too much side suction makes the plow bottom take too wide a cut, resulting in a poor job of plowing.

Down suction is regulated by altering the distance that the bottom of the share and landside deviate from a straight line. Side suction is adjusted in the same general manner. The nominal clearance required for both down suction and side suction is 0.7 cm (0.3 in). As the share wears, the offset required for proper suction decreases, and insufficient suction results. Proper suction can be restored by sharpening or replacing the share. Figure 4.14 and 4.15 illustrate the offsets for down and side suction.

4.14. Offset for down suction.

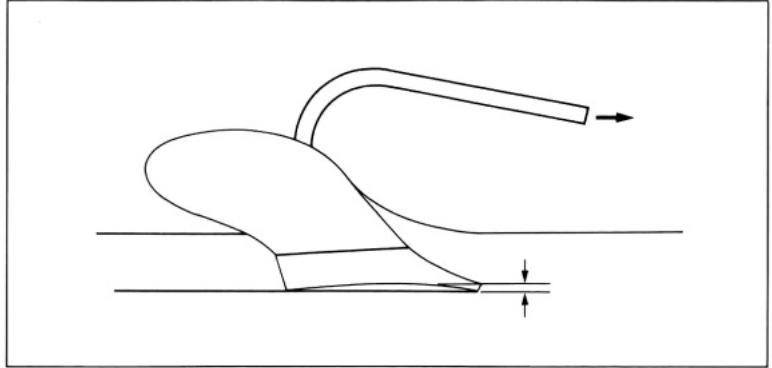

4.15. Offset for side suction.

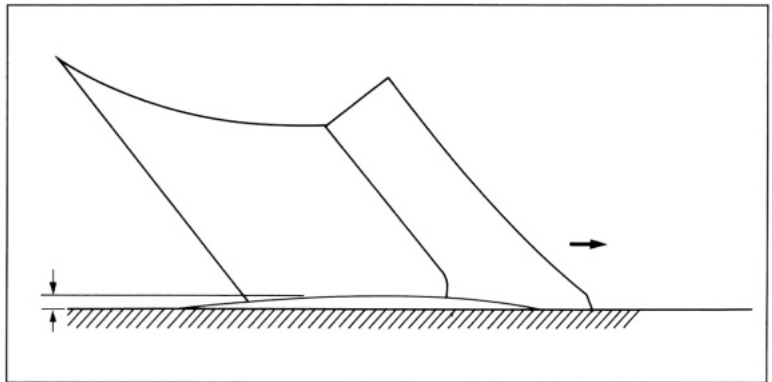

The water buffalo-drawn single moldboard plows used to plow ricefields perform well in the plastic soil of a ricefield, but they are unsatisfactory on upland soil, since the point and the share are not shaped to obtain sufficient suction to penetrate and operate at the desired depth in dry soil.

Moldboard plows are usually right-hand plows. When one stands behind the plow facing the direction of travel, the landside is to the left and the moldboard to the right, so that the furrow slice is thrown to the right: A left-handed plow has the moldboard on the left and the landside on the right, and throws the furrow dice to the left.

Some single-bottom walking plows designed for draft animals allow for the moldboard and share to operate either right- or left-handed. In North America, this type of walking plow is referred to as a hillside plow, since the reversible feature allows all the furrow slices to be thrown up the hill.

When plowing irrigated or contoured land, it is often advantageous to be able to use a right-hand plow in one

direction and a left-hand plow in the opposite. To accomplish this, a left-hand and a right-hand plow are mounted on a common frame. This unit is called a two-way or a reversible plow.

The size of a moldboard plow is determined by the width of the plow bottom and the number of bottoms. For example, a 3-14 is a 3-bottom plow with each bottom cutting a 14-inch (36-cm) furrow.

The width of a moldboard plow is the perpendicular distance from the soil-contacting side of the landside to the wing of the share. A moldboard plow is generally designed to plow at a depth equal to half the bottom's width of cut. For example, a 14-in (36-cm) plow will easily plow 7 in (18 cm) deep. Multi-bottomed tractor plows of variable width complicate the matter of plow size. A typical 7-bottom variable width unit can plow at bottom widths of 35-56 cm (14-22 in). The plow bottoms are attached to the frame so that by hydraulically adjusting the angle of the plows beam, the furrow cut can be changed to the desired width between a minimum of 2.5 m (8.2 ft) and a maximum of 3.9 m (12.8 ft).

A plow can also be categorized according to its prime mover. An animal-drawn plow controlled by a man on foot is called a walking plow. If the plow is mounted on wheels and the plowman rides, the unit is called a sulky plow. Tractor-drawn plows are categorized by the method of attachment to the tractor: trailing, mounted, or semimounted.

The trailing type plow is essentially a sulky plow pulled by a tractor. Today, trailing plows are rarely used with tractors, since the hydraulic systems and weight transfer arrangements on modern tractors are far more convenient.

The mounted plow is fully mounted on the tractor and is lifted from and dropped into the soil by the tractor's hydraulic system. A mounted plow is less expensive than a trailing or semimounted plow, since it requires less framework. When it is lifted for transport, however, the entire weight of the plow overhangs the rear of the tractor, so mounted plows are limited to about four bottoms in the interest of stability and safety. If the tractor has both front and rear three-point hitches, mounted plows can be hitched both front and back. A typical arrangement is a four-bottom mounted plow on the rear and a three-bottom unit on the front.

Semimounted plows are the most popular type of moldboard plow arrangement in North America. The semimounted plow is a compromise between the trailing plow and the full or integral mounted plow. Like the trailing plow, a rear furrow wheel carries some of the weight. This wheel is usually steerable on multi-bottomed plows to enable the tractor to turn within a reasonable distance. Like the fully mounted plow, the front is attached to the tractor's three-point hitch and raised and lowered hydraulically. The lift linkage on such a plow is devised so that the bottoms do not enter or leave the soil at the same instant. To make straight headlands, the front bottom enters the soil while the rear bottom is still raised. The rear bottom automatically enters the soil at the same distance from the starting point as did the first bottom.

Although the plow bottom is the heart of a moldboard plow, certain accessories are necessary for good plowing under various conditions. Coulters and jointers, for example, are used to cut the furrow slice loose from the furrow wall, thus preventing the shin from tearing it loose. By eliminating the tearing action, plow draft is reduced. Coulters or jointers are especially useful when plowing sod.

A knife coulters is a vertical steel knife bolted to the plow beam so that the point of the knife is above the point of the share. On some plows, the knife coulters is bolted to the landside of the share and protrudes upward. This design is called a fin coulters.

A rolling coulters is a hard steel disc with a sharp edge. It is usually flat, but it often resembles a section of a sphere. Not only does the rolling coulters cut a smooth furrow face, but it cuts surface trash better than other coulters. Rolling coulters are available in plain, notched, and ripple-edge discs. The plain coulters is the least costly and performs satisfactorily when there is little surface trash. The notched coulters will hold down and cut heavy trash, such as maize stalks, but is more difficult to sharpen than the plain coulters. Ripple-edge coulters cut like serrated knives. They are more positively rotated by their engagement in the soil than the other rolling coulters. Ripple-edge coulters are also self-sharpening.

Large-diameter rolling coulters are better for cutting trash than smaller diameter coulters, which tend to push heavy trash ahead instead of cutting through it. On the other hand, large diameter coulters do not penetrate the soil as easily as

small ones. When plowing hard soil, the coulter is set at shallow depth and rearward of its usual location so as not to adversely affect the penetration of the plow. The diameter of a rolling coulter should be equal to or larger than the size of the plow bottom with which it is used.

For average plowing, the coulter is set slightly ahead of the share. It is adjusted to cut to half the plowing depth. The coulter is installed about 2 cm (0.75 in) from the outside of the landside.

A jointer is a miniature plow. Its purpose is to turn over a small ribbon of soil directly above the plow point, thus helping the plow bottom to turn the furrow. A jointer is mounted on the plow beam in the same manner as a knife coulter. Where surface trash exists, jointers perform better than knife coulters, but not as well as rolling coulters.

Shock protection devices prevent breakage of the share, twisting of the plow standard, or warping of the beam or frame. Various types of devices are utilized. Walking plows usually have no shock absorbing features. Sulky plows utilize a shear bolt or a spring-loaded latch to protect the plow when it strikes an obstruction. Integral mounted tractor plows cushion the shock of hitting an obstruction with either a breakaway spring latch or a hydraulic system that releases the plow.

Tractor-drawn plows of one to three bottoms generally utilize a spring reset arrangement. When the bottom strikes an obstruction, it is lifted out of the soil by the combination of forward travel and spring action. The plowman must then reverse the tractor and plow to reset the bottom. This system is inefficient for large tractors and plows. For example, if one bottom of a seven-bottom plow strikes an obstruction and pivots out of the soil, it is necessary to back up the entire rig to retrieve it, thus interrupting the work of the six other bottoms.

Automatic trip beams actuated by springs, air pressure, or hydraulic are used with most moldboard plows of four or more bottoms (Fig. 4.16). The hydraulic system is the most common. With automatic trip beams, it is not necessary to stop or even reduce speed when a bottom strikes an obstruction, since the bottom will disengage and reenter the soil after passing over the obstruction

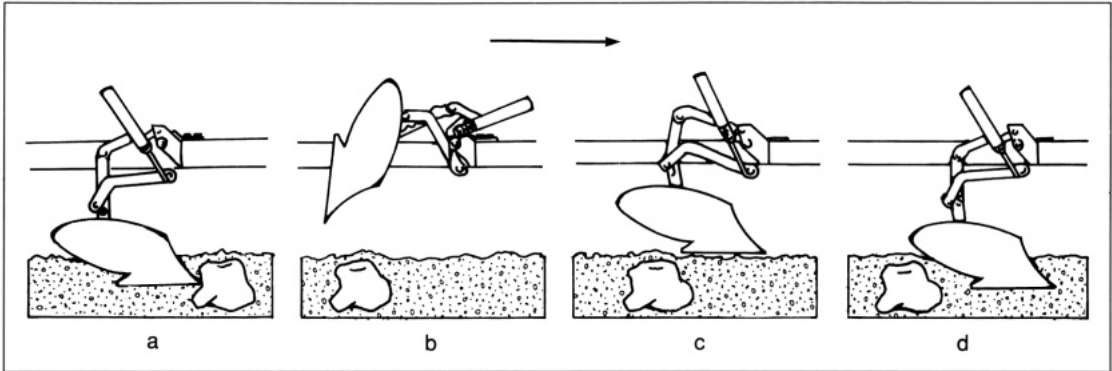

4.16. Action of an automatic trip beam when plow bottom hits rock.

All moldboards lift, fracture, and invert the furrow slice, but significant differences exist. Moldboard shapes are designed according to soil characteristics, degree of covering desired, speed, and draft restrictions. Of the hundreds of moldboard shapes, the most important are the sod, stubble, general purpose, high speed, and slatted.

The long, low sod moldboard is designed for turning virgin sod or land that has been idle for a long time. It is sometimes called a breaker bottom. The sod moldboard provides a long, augerlike twist to the furrow slice so that the slice is completely inverted.

The stubble moldboard is wide and has an abrupt curve that causes the furrow slice to be thrown over quickly. It pulverizes the soil better than other types of moldboards. This moldboard performs best on annually cultivated land.

The general purpose moldboard is a cross between the sod and stubble designs. It provides the farmer with one moldboard suitable for general farming.

The power of farm tractors has increased faster than their draft capabilities; therefore, farmers are plowing at higher speeds today than they were two or three decades ago. Since $\text{drawbar horsepower} = \text{draft} \times \text{speed} \times \text{constant}$, if draft is limited because of wheel and soil conditions, the farmer plows at a higher speed to utilize his available tractor power. A stubble bottom that plows well at 4 km/h does not suffice at high speed. The abrupt curvature of the stubble moldboard throws the furrow slice too far, and may even roll the slice 360° and leave it uninverted. The high-speed bottom has a longer moldboard with less curvature, and turns the furrow evenly when drawn at high speeds.

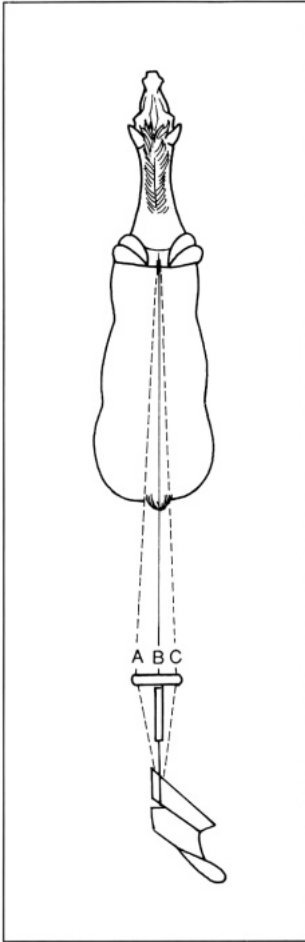

4.17. Horizontal adjustment of walking plow.

Slatted moldboards are used in soils that do not scour well. Longitudinal sections of the moldboards are removed, leaving only about half the moldboard surface intact. The remaining moldboard surface produces higher soil pressure, thus preventing the soil from sticking to the moldboard.

Proper hitching of the plow to the draft animal or tractor is equally important as selecting the correct plow. When properly hitched, the plow's load vectors are in equilibrium with the pulling vectors of the tractor or draft animal. The center of resistance of a moldboard plow bottom is on the surface, to the right of the shin (for a right-hand bottom) where the share butts against the moldboard. The line of pull is an imaginary straight line with the center of resistance at one end and the center of power at the other. To secure a good hitch and to prevent sidewise pull and energy waste, the line of pull must pass through the clevis, or hitch point. The horizontal vector of the line of pull is the line of draft (Fig. 4.17, 4.18). The line of draft must pass through point B in Figure 4.17. If it passes through points A or C, the plow will pull sidewise. In Figure 4.18, the line of draft runs from the harness hames to point G at the plow's center of resistance. Since the line of pull passes through point E, the hitch point must be E. If the hitch point is D, the plow goes deeper into the soil. If the hitch point is F, the plow is too shallow. When the plow is adjusted properly, the plowman does not need to fight it. The only strenuous work occurs when turning at the end of the field.

The importance of hitching also applies to multi-bottom tractor plows. The center of resistance on a plow bottom is about $1/4$ the width of cut. For an 18-inch plow bottom, for example, the center of resistance is $4\ 1/2$ inches from the shin, or $13\ 1/2$ inches from the wing tip of the share. By adding half the width of cut for each additional bottom, the horizontal center of resistance is determined. For example, a 5-18 plow's center of resistance as measured from the right will be $13\ 1/2 + 9 + 9 + 9 + 9 = 49\ 1/2$ in. To make the plow run straight, the line of draft between the center of resistance and the center of power on the tractor must pass through the proper hitch point (Fig. 4.19). Since the center of resistance is an estimate, it is advisable to adjust the hitch point after observing plowing performance. If the plow cuts less than nominal width, the hitch must be moved to point B. If the plow cuts

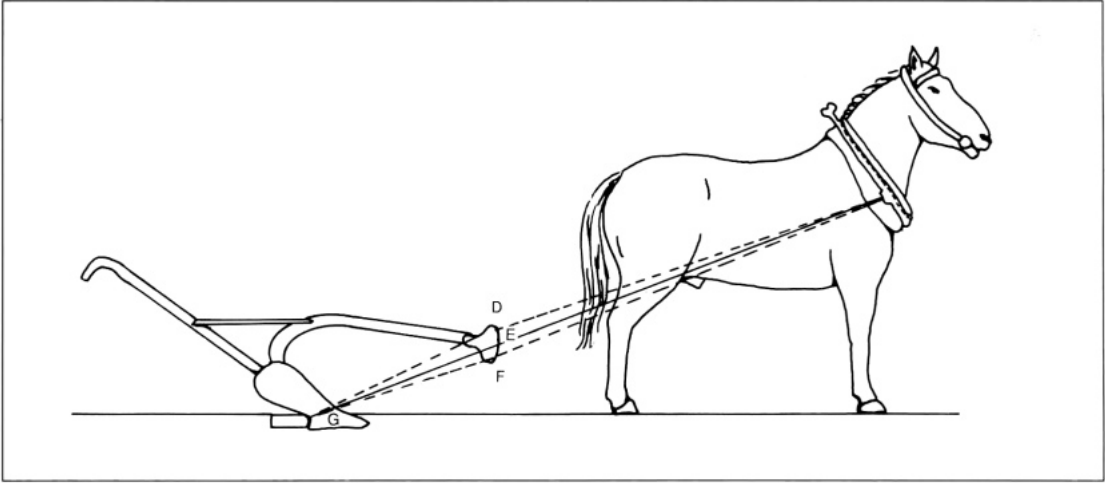

4.18. Vertical adjustment of walking plow.

greater than nominal width, it must be hitched at point C. The same procedure is applicable to the vertical hitching of tractor plows. Vertical hitch adjustments can be made at the plow hitch or tractor drawbar for trailing and semimounted plows. When pulling up to five bottoms, the right-hand wheels of the tractor travel in the furrow while the left-hand wheels are on the land (unplowed soil). For five or more bottoms, it is possible to hitch so that all wheels of the tractor are on the land.

Plow draft and power required for moldboard plows depend primarily on the type of soil plowed and the speed with which it is plowed. Table 4.4 provides typical values for a 4-bottom 16-in (45-cm) moldboard plow plowing to a depth of 8 in (20 cm). For plows of other sizes, drafts and horsepower can be prorated according to plowing width, depth, and number of bottoms.

4.19. Hitching a tractor plow.

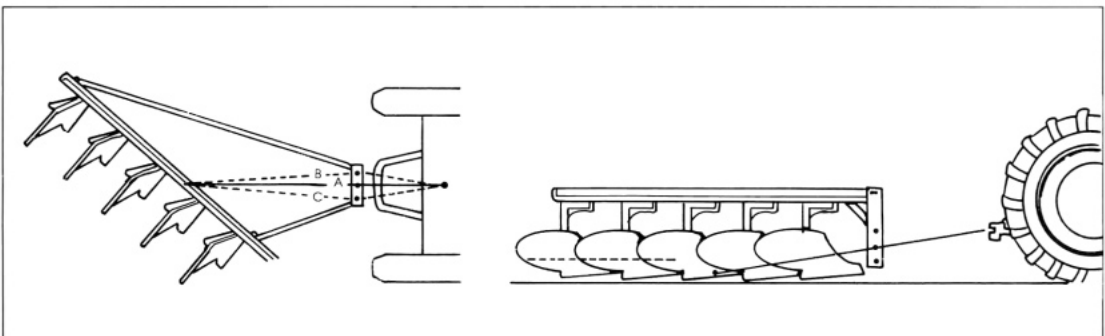

Table 4.4. Power required for a 4-16 moldboard plow at 8-in (20-cm) plow depth.

Speed (km/h)	Power required (dwb hp)			
	Sandy	Sandy loam	Loam	Clay
3.2	6.9	14.4	21.8	26.0
4.8	11.2	22.4	35.2	40.7
6.4	16.0	33.0	50.0	59.6
6.0	21.3	48.0	72.0	89.4
9.6	33.3	70.4	105.5	123.0

4.10 Disk plows

The disk plow (Fig. 4.20) is used for primary tillage to invert the soil or to mix the surface vegetation. A disk plow requires about 10% more draft per area of soil turned than a moldboard plow, but it is preferable to the moldboard plow when

- the soil contains large roots or stone ledges;
- the soil is sticky, and a moldboard cannot scour;
- the soil is dry and hard, and a moldboard plow does not penetrate to the desired depth; or
- tractor operators are not well trained.

A disk plow consists of a frame containing one to seven concave steel disk blades and a tail wheel. The diameter of the disk blades is 61-97 cm (24-38 in.). The blades are made from 5-6 mm steel and are shaped like sphere segments. They are set so that the face of the blade is at about a 45° angle to the direction of travel and tilted rearward 15-25° from the vertical. Setting the disk blade farther from the vertical improves penetration in heavy or sticky soils, while setting it closer to the vertical improves performance in loose or brittle soils, and provides better trash coverage.

4.20. Semimounted disk plow.

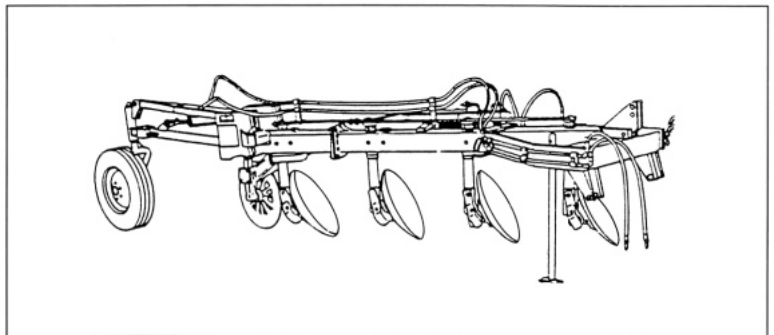

Each disk blade makes a cut 18-30 cm (7-12 in) wide, depending on disk diameter and setting. Unlike a moldboard plow, a disk blade creates no suction. Weight must be added to force the blades to penetrate deeper. Each blade carries a weight of 200-600 kg (450-1300 lb). Disk blades are available with either plane bevel or notched edges.

Since the rear wheel must carry most of the side thrust of the plow, its correct adjustment is crucial. Disk plows can be used as two-way plows if the blades are mounted so that they can be rotated about vertical axes to face either the right-hand or the left-hand sides of the plow.

4.11 Laying out a field for plowing

Since moldboard and disk plows not only invert the soil, but move it laterally, the field must be laid out with forethought. Plowing is most efficient if the field is divided into rectangular lands as illustrated in Figure 4.21. A land should be at least three times as long as it is wide. It is easier to plow a few long furrows than many short ones.

First, the turning areas, called headlands, are laid out. Headland width should be twice the length of the tractor and plow. Most plows throw the earth to the right. In each land there will be an undesirable hack furrow at the center and a dead furrow on each side. A dead furrow is an unfilled trench. A back furrow is a ridge made by throwing a furrow slice on unplowed ground.

One method of laying out a field for plowing is to first plow from A to B (see Fig. 4.21) and then from B to A, creating a back furrow. Plowing continues clockwise. Turning is done on the headlands with the plow raised off the ground. When a land is finished, dead furrows will be at C-E and D-F. The headlands are plowed after all the lands have been plowed.

For a novice farmer with a small plot, it is a good idea to begin plowing on one side—D-F or C-E, for example—and then deadhead back to the starting point and plow the field in only one direction. One back furrow and one dead furrow will result from such a plowing plan.

4.12 Rotary tillage tools

Rotary tillage tools include spading machines, vertical axis rotary tillers, and horizontal axis rotary tillers. The spading machine is a complicated device that mechanically emulates the action of a spade as used by a human. The spading machine makes it possible to plow wet, clay, upland soils

4.21. Plowing a land.

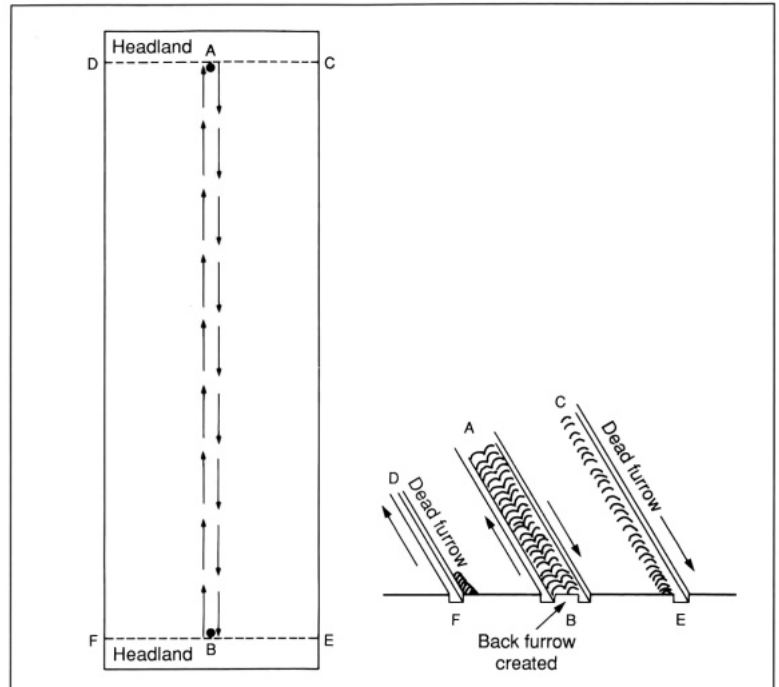

without traction problems since it requires little or negative tractor draft. Although spading machines have been used in Great Britain, they have not been accepted in other areas because of their slow speed and high cost.

The vertical axis rotary tiller, when used with pedestrian tractors for once-over land preparation, does not leave a flat, even seedbed like the horizontal axis rotary tiller. However, it is useful for creating ridges and hilling up row crops. Some power harrows (discussed subsequently) are vertical axis rotary tillers, but they are designed for secondary rather than primary tillage.

The tillage tines for mounting on the axle of the single-axle pedestrian tractor in Figure 2.3, and the tiller shown on the double-axle pedestrian tractor in Figure 2.5 are horizontal axis rotary tillers, which have found wide acceptance. The horizontal rotor machine in Figure 4.22 is the best general-purpose rotary tiller for farm tractors, and is practically the only type in use today. The larger rotary tillers for use on farm tractors are discussed in this section.

A comparison of the operating characteristics of three tractor-mounted rotary tillage machines and a two-bottom

4.22. Tractor-mounted rotary tiller.

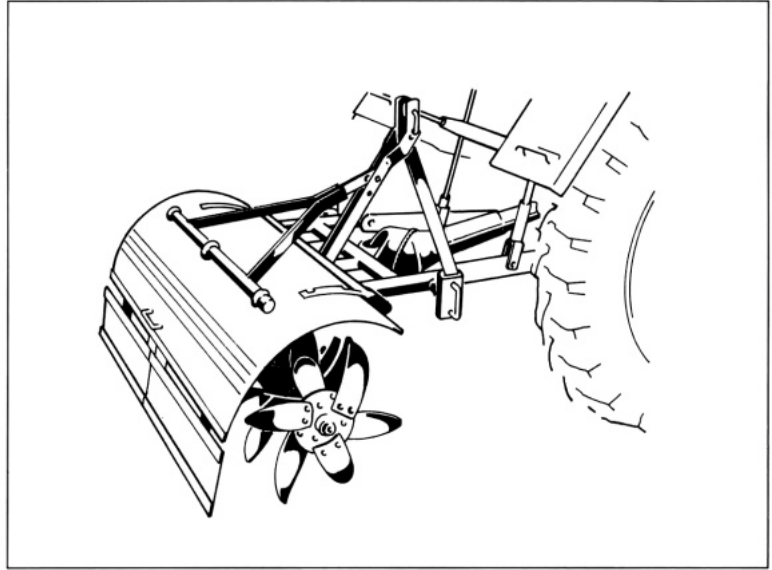

moldboard plow is made in Table 4.5. The spading machine had a working width of 6 ft (1.8 m), and the two rotary tillers, 5 ft (1.5 m). The vertical rotor machine in Table 4.5 was a heavy-duty rotary tiller designed for primary tillage.

The rotary tiller has two unique features: 1) it combines primary and secondary tillage in one operation, and 2) it provides negative draft, since the rotor and the earth-engaging tines rotate in the same direction as the tractor wheels. The rotary tiller is powered by the tractor's PTO. When the tiller is working, it exerts a forward push on the tractor. The tractor retards the push of the tiller by means of soil resistance to the tires, transmission, engine, and brakes. If the transmission clutch is disengaged while the rotary tiller is working under full power, the absence of the restraining force of the tractor

Table 4.5. Rotary tiller performance on clay soil with crop residue.⁷

Machine	Working depth in inches (cm)	Rotor speed (rpm)	Forward speed in mph (km/h)	PTO hp	Draft in lb (N)
Horizontal rotor	4 (10)	180	1 (1.6)	22	25 (111)
Vertical rotor	4 (10)	215	1 (1.6)	20	230 (1023)
Spading machine	8 (20)	27	1 (1.6)	20	200 (890)
Two-bottom moldboard plow	8 (20)	—	3 1/2 (5.6)	—	2100 (9340)

wheels causes the tractor to accelerate. The tractor must be operated with direct-drive transmission gear, and not with a freewheeling transmission.

The once-over feature of the rotary tiller is advantageous because only one implement is required for tillage. The disadvantage, however, is that combining several energy intensive jobs into one creates the need for a large tractor. The rotary tiller uses about three times as much energy to move and pulverize 1 cm³ as does a moldboard plow. The combined energy requirement for plowing with a moldboard plow, disking, and harrowing may be less than that required by a rotary tiller. For example, a 200-cm (79-in) tiller operating 13 cm (5 in) deep in a medium soil at 5 km/h (3 mph) requires a 125-hp tractor. Higher speed, greater tillage depth, heavier soil, and increased rotor speed for finer soil particles require greater horsepower. For this example, the tilling rate is 0.7 ha/h (1 3/4 acres/h).

Since tractor and rotary tiller movement do not depend on traction, the tractor does not require the additional weight used to provide greater draft. As a result, a tractor powering a rotary tiller can have very good flotation. When a rotary tiller is used for puddling ricefields, the tractor has all excess weight removed and becomes little more than a steerable engine for the tiller.

Except for puddling ricefields, there is danger in working wet soils with rotary tillers. Since traction is not a problem, it is tempting for the farmer to begin working the soil before it is properly moist. Sandy soils do not pose a serious problem, but clay soils have a moisture range over which a rotary tiller cannot easily do a satisfactory job (moldboard or disk plows are preferable). Many clay soils are dry on the surface, while the soil 10-15 cm deep is quite wet and plastic. If a clayey soil in this condition is plowed with a moldboard or disk plow, the soil is inverted, and by the time the new surface soil dries, the secondary tillage can be accomplished with a disk harrow or spring-tooth harrow. If this wet, clayey soil is tilled with a rotary tiller, however, a very undesirable seedbed filled with mud balls and clods is created. A farmer using a rotary tiller to prepare a clayey soil under wet conditions for upland cultivation must exercise caution.

Excessive pulverization of the soil under optimum soil moisture can occur if rotor speed is too fast, forward speed is

too low, soil shield is set too low, or there are too many tines. Excessive soil pulverization can damage soil structure below the surface and create crusting on the surface. Rotary tillers are not usually used in stony soil because of the high cost of tine replacement and excessive machine wear.

Tines are usually L-shaped. L tines work well in heavy trash. C-shaped tines are more curved than the L tines and are useful in penetrating hard soil or in alleviating rotor clogging in wet, heavy soils. Straight, thin tines are sometimes used to reduce power requirements when breaking clods and removing weeds in secondary tillage. Tines are usually bolted to flanges attached to the rotor and are attached in pairs of left-hand and right-hand tines.

Combinations of short and long tines can be used for strip tillage. For example, long tines are spaced along the rotor to till narrow strips where seed is planted, while short tines are attached to the rotor between the long tines. The short tines remove weeds and mulch on the surface, while the longer tines prepare the seedbed.

The spiral plow is a tillage implement for a single-axle pedestrian tractor and is used primarily for tillage in flooded ricefields. It consists of a right-hand and a left-hand auger, mounted on the axle in place of the cage wheels. The augers move the soil toward each side of the tractor, and the comb harrow smooths and levels the earth and stubble loosened by the spiral plow. A typical spiral plow has an outside diameter of 41 cm (16 in) and a width of 57 cm (22 in). Soil tilling is regulated by braking the tractor with the comb harrow to adjust forward speed—the slower the speed, the finer the tilling. In soft mud condition, the spiral plow is more difficult to turn than a pedestrian tractor equipped with a moldboard plow or a double-disk plow. Research in the Philippines in which implements mounted on single-axle pedestrian tractors were compared in tilling ricefields with a “normal depth of soft mud layer” revealed that the moldboard plow had a capacity of 0.11 ha/h; double-disk plow, 0.14 ha/h; cage wheels and comb harrow, 0.15 ha/h; and spiral plow, 0.16 ha/h. In deep soft mud, the disk plow and the spiral plow bogged down.⁸

4.13 Harrows

Harrows, classified as secondary tillage implements, are used to prepare seedbeds, remove weeds, break crusted soil, and aerate pastures. The primary types are the spike-tooth,

spring-tooth, chain link, disk, and power harrows. Spike-tooth harrows are also called peg-tooth, drag, zigzag, section, or smoothing harrows. Rotary and reciprocating harrows can be powered by the tractor PTO. All harrows are pulled as draft implements.

The comb harrow, a one-bar spike-tooth harrow, is described in the section on puddlers, since it is used exclusively for preparing fields for wetland rice cultivation. Another type of simple spike-tooth harrow for upland tillage, the triangular harrow, is a spike-tooth harrow with pegs (teeth) set into a triangular frame (Fig. 4.23). The working width is 1.5 m, and the harrow is often animal drawn. In primitive agriculture, both teeth and frame are made of wood, while factory-built triangular harrows are usually made of steel.

The spike-tooth harrow consists of steel teeth, rectangular in cross section, set vertically into a horizontal frame so that they form a zigzag pattern to prevent the rear teeth from following in the tracks of the front teeth. These harrows range from 1 to 9 m in width, with teeth 16-20 mm square. A heavy harrow used for crumbling clods carries about 2 kg of frame weight per tooth. Lighter harrows, called tine-tooth harrows, have wire teeth up to 75 mm in diameter and weigh about 0.5 kg per tooth. Tine harrows are used for final seedbed preparation or for breaking crusted soil.

The basic unit of spring-tooth and spike-tooth harrows is called the section, which is a rigid frame 1.2-2.2 m wide. Open-ended frames have only front and side frame members, while closed-ended frames feature a rectangular frame. The

4.23. Triangular harrow.

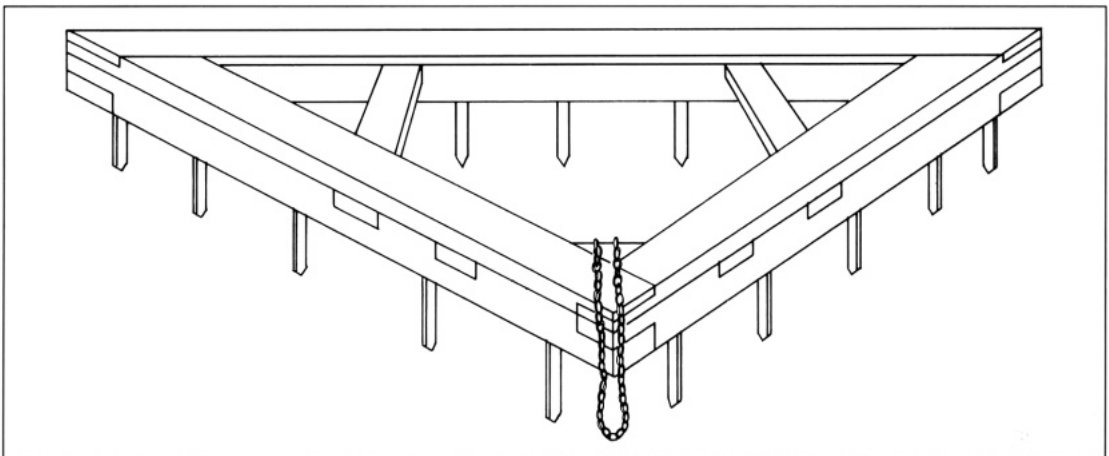

closed-ended frame is stronger, but the open-ended frame allows less clogging by surface debris. Sections can be hinged together to form a wider harrow. Harrows are easily shipped by sections, and harrow width can be quickly adjusted for use in uneven fields.

Harrows work up to 10 cm deep. The frame must be parallel to the ground for best results. When preparing a seedbed, a scrubber boards is often attached to the front of the harrow, and a drag or crumbler to the rear to obtain a smooth surface for planting small seeds.

The spring-tooth harrow (Fig. 4.24) has deeper penetration and more aggressiveness toward weeds than the spike-tooth harrow. It is better than the disc harrow in stony conditions, but plugs in heavy trash. A spring-tooth harrow has three to six sections, and three toothbars per section. It has teeth on 30-cm spacing, providing a working tooth every 10 cm. Teeth are made of spring steel, 8 x 44 mm in cross section. All the teeth can be pivoted with a single lever. For light surface harrowing with little soil penetration, the working tips of the tines are vertical; for deep, aggressive work, the tips are nearly horizontal. Heavy-duty wheeled spring-tooth harrows are made in widths ranging from 3.5 to 12 m.

A chain-link harrow, shown in Figure 4.25, has no rigid frame. It is woven from 1- to 1.5-cm steel wire into links like a wire mesh fence. A spiked tooth extends from each link. For aggressive action, the harrow is laid out with the spiked teeth down. For less aggressive action, the harrow is flipped over.

4 24. Spring-tooth harrow.

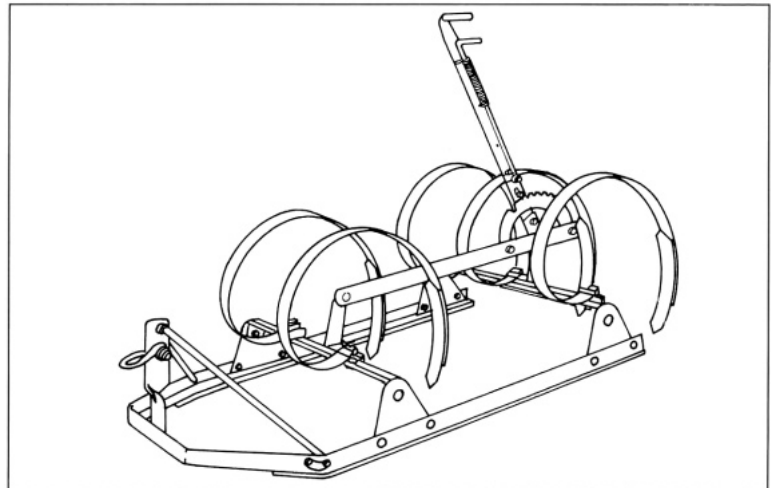

Sections are 1.5 m wide, and assembled harrows consist of 1-6 sections. A pipe across the front of the woven net of chain links serves as the drawbar. The chain harrow is useful for pesticide incorporation and pasture aeration as well as seedbed preparation. It hugs the soil surface better and is less expensive than other harrows. A disadvantage is that some models are difficult to lift and move because of the lack of a frame.

Disk harrows are used for seedbed preparation, chemical incorporation, weed control, and diking heavy crop residues before plowing. The tandem disk (Fig. 4.26) is developed

4.25. Chain-link harrow.

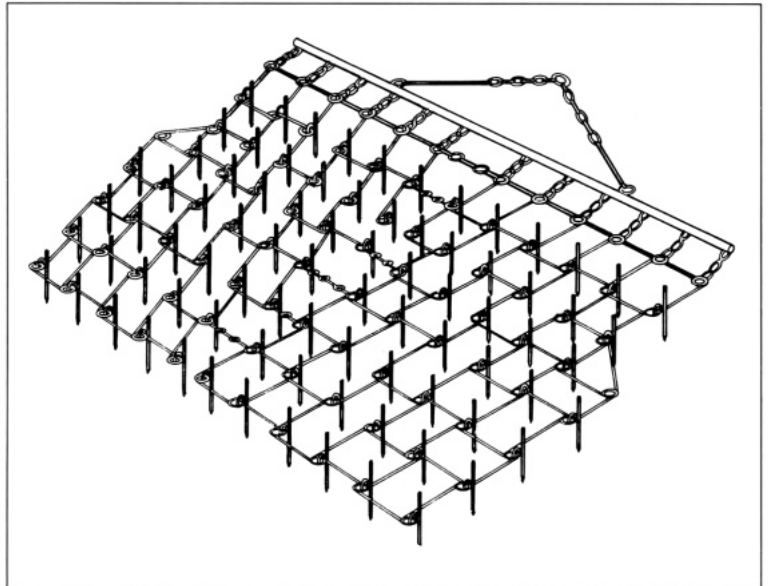

4.26. Tandem disk harrow.

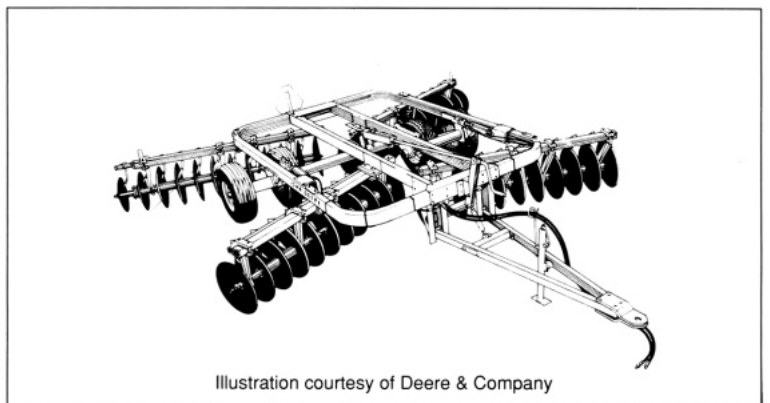

119 DIBBLE STICKS, DONKEYS, AND DIESELS

from the single-action disk (Fig. 4.27), and the double offset disk from the single offset disk (Fig. 4.28). Rear blades of a tandem disk are set to follow half-way between the front blades. The disk blades rotate as the disk is pulled along. The action of the disk on the soil depends on the diameter of the disk blade, the weight of the disk, and the disk gang cutting angle.

Disk blades are 35-80 cm in diameter. Blades of 40-50 cm diameter are popular for horse-drawn disks, while 45- to 80-cm-diameter blades are used for tractor-drawn disks. The

4.27. Disk harrow (single action).



4.28. Offset disk harrow.

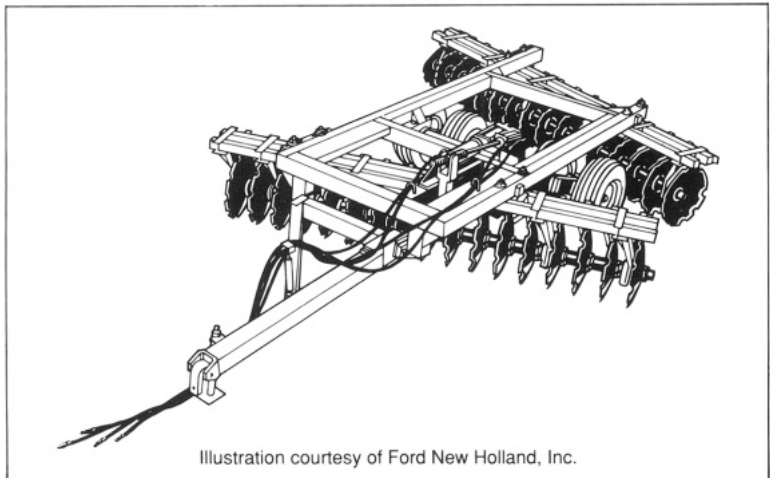

disks are conical or spherical in shape and are made of heat-treated high-alloy steel. Disk blades are made both notched (scalped) and plain. Notched blades penetrate and cut through trash such as maize stalks better than plain disks.

Disks are assembled from right-hand and left-hand gangs. A single-action disk consists of a right-hand and a left-hand gang. The side draft of one disk cancels out the side draft of the other. A single-action disk harrow with the convex sides of the disks toward the center moves earth outward from the ends of the harrow. By reversing the left-hand and right-hand sections so that the convex sides face outward, two single-action disks can be placed in tandem. Thus, the rear blades move the earth back to its original position. The disk gang cutting angle is the angle between a line perpendicular to the disk axle and the line of travel. The angle can be varied from about 10° to 25°. On an offset disk, the angle may be as much as 50°. Increasing the cutting angle provides increased penetration, trash cutting, and covering, but requires greater draft force. Penetration depends primarily on weight per blade, while seedbed fineness depends on blade spacing (Table 4.6). Ballast can be added to disk harrows to increase weight. Alternately, weight transfer hitches are available for adding tractor weight to the harrow by means of hydraulic links.

An offset disk harrow is a single right-hand or left-hand section that utilizes side draft to offset the harrow from the tractor track. With an offset disk harrow, it is thus possible to disk under trees too low to permit a tractor to pass. When right-hand and left-hand offset disk gangs are connected in tandem, the side forces cancel, and the implement runs on the tractor track. If it is necessary to operate a tandem offset disk off to the side of the tractor, one can offset the tractor hitch up to about half of the desired offset and obtain the remainder

Table 4.6. Typical disk harrow blade spacing and weight per unit length of gang.

Disk blade diameter		Blade spacing		Weight per unit length	
cm	in	cm	in	kg/m	lb/ft
40-55	16-22	18-23	7-9	60-165	40-120
50-60	20-24	20-25	8-10	120-240	80-160
60-66	24-26	23-30	9-12	225-375	150-270

by running the rear offset disk at a shallower depth. Heavy offset disk harrows with large disk blades (8 mm thick, 80 cm diameter) are commonly used for clearing land as well as for primary tillage. In North America, these heavy offset disks are commonly called Rome plows. Disk harrows can work deeper and pulverize the soil better than the spike, spring-tooth, or chain-link harrows, but require much more power per unit of width.

The power harrow is a tractor-mounted, single-pass secondary tillage tool that uses power from a tractor's PTO to drive the harrow tines in a reciprocating or a rotary motion. Power harrows stir the soil and are used primarily to form seedbeds for vegetable crops and to incorporate herbicides. The power harrow replaces separate operations with disk harrows and spring-tooth or spike-tooth harrows. Speed is approximately 5 km/h, depending on available power and desired soil tilth. In light soils, the power harrow may also be used for pasture reclamation and primary tillage. Working depth is controlled by adjusting the height of a crumbler roller or by depth-control wheels supporting the rear of the machine.

Since the soil-engaging tines of a power harrow are powered by the PTO, less traction is required at the tractor drive wheels. This allows the reduction of tractor ballast, and thus increases tractor flotation. There are four generic types of power harrows: reciprocating, rotary, semirotary, and spike-rotor.

The reciprocating power harrow (Fig. 4.29) is probably the most common power harrow. It has vertical spike tines attached to horizontal tine bars. The soil is stirred by the interaction of the sideways reciprocating movement of the tines and the forward movement of the tractor. Typical reciprocating power harrows have 25-cm-long tines 18-30 cm apart on tine bars 2.5 to 5 m long. Most reciprocating power harrows have two tine bars, although four-tine bar units are available. A 3-m-wide, 2-bar reciprocating power harrow weighs 500 kg, requires a 70-hp tractor, and travels about 5 km/h. The slower the speed, the finer the tilth. Steel scuffing-boards are clamped to the reciprocating tines to provide a smoother seedbed.

Rotary power harrows have two or three long tines on vertical rotors and provide a rotary stirring of the soil as the

4.29. Reciprocating power harrow.

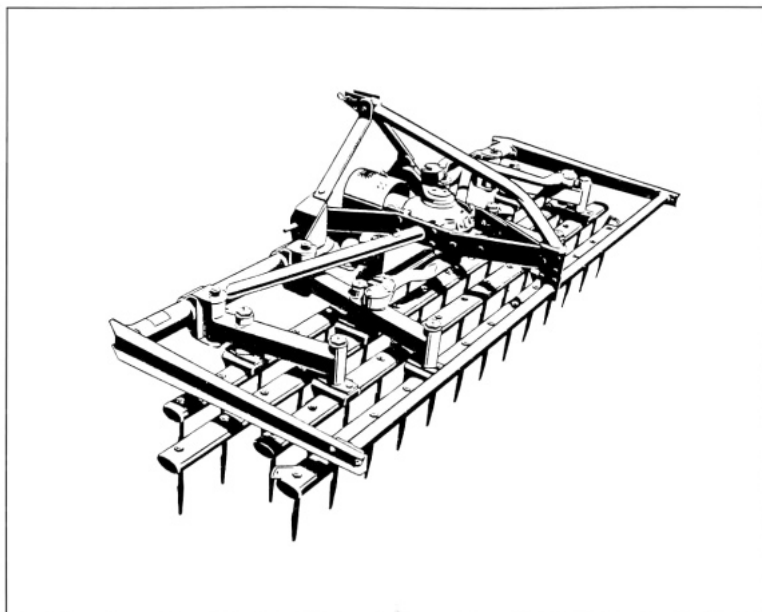

tractor moves forward. The semirotary harrow is a cross between the rotary and the reciprocating types. Pairs of tines are driven through an oscillating bearing. The spike-rotor is the simplest power harrow. It is a powered rotor with spikes projecting radially from the rotor. In general, the spike-rotor tends to invert the soil more than the other types of power harrows and does not prepare as fine a seedbed.

Surface trash such as straw, stover, and potato haulm adversely affects power harrow performance because, unless it is well chopped, the trash will catch in the tines, bunch between bars, or wrap on rotary heads. Power harrows are also prone to damage by stones, which can bend or snap tines. In nonstony soils, tines should last from 20 ha on abrasive soil to 200 ha on silt.

When matching a rotary power harrow to a farm tractor, a rule of thumb is that 23-30 maximum PTO hp/m (7.9 hp/ft) width is required for satisfactory operation. For example, a 2.5-m (8.2-ft)-wide power tiller requires a 60-hp tractor.

Crops such as cassava, potato, maize, yam, etc. are grown on ridges or beds in some farming systems. The top of a ridge is only wide enough to accommodate one row of plants, while a bed has sufficient width for two rows of plants. Water is fed into the ditches between the ridges or beds in irrigated

farming systems. Ridgers—also known as middlebreakers or ridging plows—are used to make the ridges. In light soils the ridges are made without prior tillage, but in heavier soils or in soils with heavy crop residue, the field is tilled to obtain a good seedbed before ridging. The moldboard type ridger is a plow point with both a left-hand and a right-hand moldboard (Fig. 4.30). They are made in both single-ridge, animal-drawn as well as multiridge tractor-mounted units. Disk ridgers and disk bedders consist of convex disks mounted on a tool bar, set at an angle to the direction of travel, and spaced so that adjacent disk throw earth into a ridge between them.

In some farming conditions where there is a minimum of moisture, the seed is planted in the bottom of the furrows made with the moldboard-type ridger. This is called lister planting. If the ridger and the planter are combined into one implement, it is called a lister.

Rotary ridging blades as shown in Figure 2.3 can also be used to form rough ridges with a pedestrian tractor. Each pass of the tractor forms one-half of each adjacent ridge.

The sides and top of ridges or beds for small-seeded vegetables are often formed into a uniform cross section with a tractor-drawn sled or with rotary bed formers. The sled-type

4.30. Tractor-mounted moldboard-type ridger.

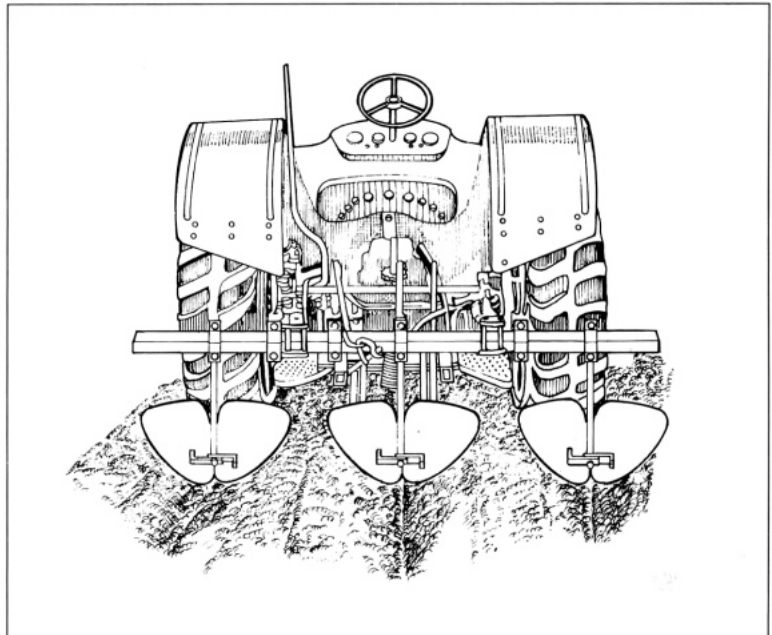

is merely a sled with “tunnels” that have the cross sectional shape of the ridge or bed. The rotary type consists of a drum about 1 m in diameter and containing grooves of the desired ridge or bed cross section. Ridge formers usually form at least four ridges or beds per pass and are frequently hitched in tandem to the ridger.

4.14 Puddlers

Land for wetland rice is often flooded for 1-4 wk prior to plowing and puddling, to weaken the mechanical strength of the soil. By retaining standing water on the ricefield, the farmer receives the benefits of weed control, oxidation reduction conditions that favor or nutrient balance, and a soft soil into which to plant rice seedlings.

Puddling helps retain standing water in the ricefield by producing fine soil particles but reduce soil porosity, thus reducing seepage. Puddling is also beneficial because it levels the soil surface and provides a homogenized soil with no clods. Puddling must be done when there is standing water on the field. In wetland ricefield, the very conditions that are disastrous for other crops are desirable.

The simplest method of puddling is done by the farmer's feet. Holding a staff in both hands for balance, the farmer works his feet up and down to break clods into smaller pieces and to smear and compress the soil. A herd of three to five water buffalo is sometimes used for puddling. The animals are driven around and around in the field so that their hooves shear and compress the soil and break down the soil aggregates. Most puddling is done with an animal- or tractor-drawn implement such as the comb harrow, ladder, or rotary puddler.

The comb harrow (Fig. 4.31) is a single-row spike-tooth harrow made of wood and steel with no moving parts. It is lightweight (10 kg) and is easily carried. A typical comb harrow is 1.2 m wide and has 13 tines 25 cm long. Comb harrows designed to be pulled by water buffalo have a top horizontal handlebar by which the farmer can change the penetration angle of the teeth. This is accomplished by rocking the handle bar backward to increase the aggressiveness of the teeth, or forward to allow weeds to slide off the teeth and thus obtain a soil-smoothing effect. The farmer adjusts for the amount of earth to be moved when puddling and leveling a wetland field in much the same manner. In a

4.31. Comb harrow pulled by water buffalo.

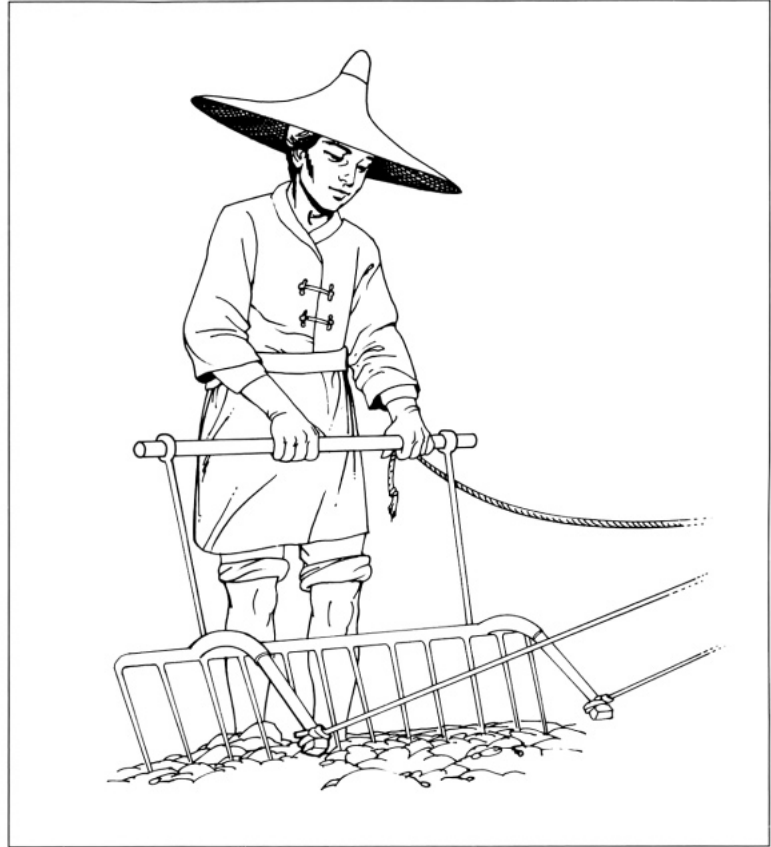

flooded field, a comb harrow requires approximately 23-46 kg of draft per meter of width, depending on whether the soil is soft or hard.

Comb harrows for pedestrian tractors have the same tooth spacing and width as those the water buffalo, but lack a handlebar for the operator. The harrow is held to the tractor by a pin, and the operator changes the aggressiveness of the harrow by vertical force on the tractor handlebars. The interaction of the comb harrow and the tractor's cage wheels provides good puddling action.

Puddling ladders are wooden and about 1.5 m (5 ft) wide. The farmer often stands on the ladder to increase the aggressiveness of the device, as shown in Figure 4.32. The ladder does a good job of leveling as well as puddling, but works best where the standing water is only a few centimeters deep. Ladders are frequently used in Bangladesh.

4.32. Ladder pulled by a pair of small bullocks.

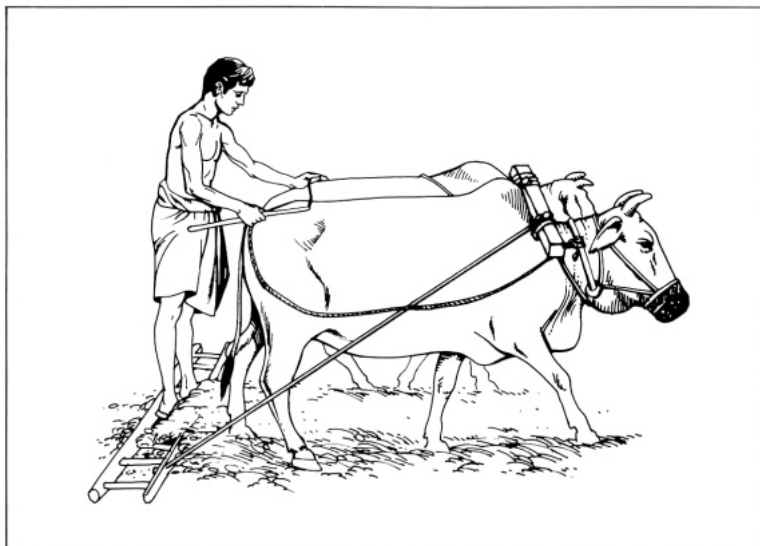

Rotary puddlers pulled by pedestrian tractors usually consist of a simple frame with one or two transverse lugged rollers. The rollers are 15 cm in diameter and have flat, steel lugs 5 mm thick and 8 cm wide. The lugs are welded radially along the rollers at 90° spacing. The resistance of the lugs in the soil rotates the rollers. The IRRI cono-puddler, illustrated in Figure 4.33, utilizes conical-shaped rotors made of sheet

4.33. Cono-puddler attached to a pedestrian tractor.

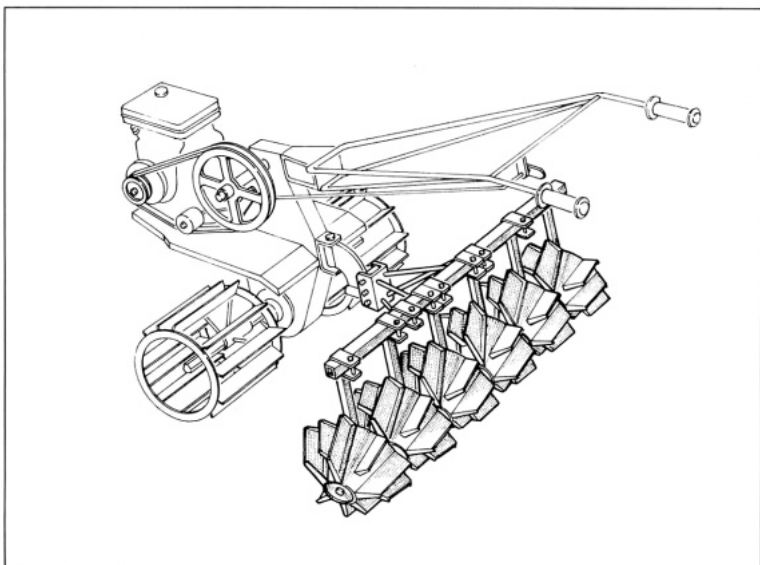

steel to create a horizontal back-and-forth action through the top 10-cm soil layer for thorough puddling with minimum energy. The rolling action of the cones pushes and buries surface weeds and trash in the mud to leave a well-puddled soil. Although the cono-puddler performs well it has not received wide acceptance because of its high cost. One- and two-gang cono-puddlers are also designed to be drawn by water buffalo. A typical cono-puddler requires a draft of 30-90 kg (65-200 lb, 295-885 N), depending on soil hardness.

REFERENCES CITED

1. Ma C Fengchow, Takasaka T, Yang Ching-wen (1958) A preliminary study of farm implements used in Taiwan province. Joint Commission on Rural Construction, Tiapai, Taiwan.
2. Food and Agriculture Organization (1976) Mechanization of rice production - India - Nigeria - Senegal, International Coordinated Research Project 1970-76, Rome.
3. Raymundo J (1981) El Rhuki, Minka, Bol. Com. Coordinadora Tecnol. Adecuada 1(2):10-11.
4. Hopfen H J (1969) Farm implements for arid and tropical regions. FAO Agric. Dev. Pap. 91. Food and Agriculture Organization, Rome, p. 46-55.
5. von Rau L (1882) Verzeichniss der Modell-Sammlung von Handgerathen und Plugen nach ihrer geschichtlichen Entwicklung (Register of the model collection of handtools and plows according to their historical development). No. 184, p. 11. Frankfurt am Main.
6. Hansen H-O (1969) Experimental ploughing with a dostrup arid replica. Tools Tillage 1:2.
7. Pascal JA (1967) Rotary soil working machines. Farm Mech. 19(211):24-29.
8. Calilung E J (1985) Comparison of land preparation equipment used on small rice farms in the Philippines. Thesis No. AE 85-2, Asian Institute of Technology, Bangkok, p. 43-48.
9. Department of Agricultural Engineering (1986) Semi-annual report, January-June, 1986, International Rice Research Institute, P. O. Box 933, Manila, Philippines. (unpubl.)

BIBLIOGRAPHY

- Bailey L H (1908) Cyclopedia of American agriculture. Vol. III. Animals. The MacMillan Co., London
- Campbell J K, Young D H (1984) Development of a muck-land ridger for lettuce production. ASAE Paper No. NAR84-101. University of Maine, Orono, Maine.
- Kline C K, Green D A G, Donahue R L, Stout B A (1969) Agricultural mechanization in equatorial Africa. Res. Rep. 6. Institute of International Agriculture, Michigan State University, Michigan.

5 Planting

Planting seed requires

- opening a hole or furrow of proper depth,
- metering the seed,
- placing the seed,
- covering the seed, and
- firming the seedbed.

Tool or machine selection for planting seed depends on the size of the seed and whether the soil has been tilled. The term *no-till planting* is used when planting seed in untilled soil.

5.1 Tools for planting large seeds

Large seeds include those of maize, beans, squash, pea, peanut, and cotton. They are easier to plant than small seeds, since individual seeds can easily be separated by human fingers or mechanical devices. Furthermore, large seeds do not usually require as fine a seedbed as do small seeds.

Manual tools for planting large seeds include the machete (Fig. 5.1), dibble stick (Fig. 5.2), jab planter (Fig. 5.3), rotary jab planter (Fig. 5.4). and push drills.

In parts of Africa where shifting agriculture is practiced, maize is planted immediately after burning. The farmer flicks the forward end of a machete into the soil, twists slightly, and withdraws it in a continuous movement. At the same time, he drops several maize kernels into the hole with the other hand.

5.1. Machete.

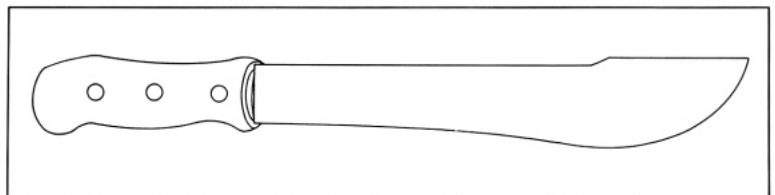

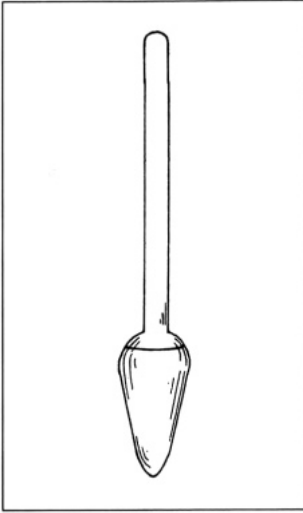

As the farmer steps forward to plant the next hill, he covers the seed and firms the soil with his foot.

The dibble stick is merely a stick to make holes in the soil. Its conical point requires less force to penetrate the soil than a blunt stick. The planting sequence is the same with a dibble stick as with a machete.

The jab planter (Figure 5.3) is commonly used in the Americas. It is a manually powered machine about 85 cm long and weighs 3.2 kg when filled with 1 kg of maize seed. At the bottom of the seed hopper is the seed plate. This can be adjusted to provide the correct hole size to accommodate the type and number of seeds desired. A typical jab planter forms a rectangular hole in the soil about 2 x 7 cm in cross section and up to 5 cm deep. The farmer carries the jab planter like a walking cane. Sticking the point into the earth and using the hole as a pivot point, the farmer pivots the planter forward about 30°. A spring-loaded foot connected to one side of the point provides relative motion to open the jaws of the point about 2 cm. The seeds dropped through the seed plate during the previous planting cycle fall into the hole. As the farmer pivots the planter back to a vertical position, a rod connected to the foot rotates the seed plate one notch. The seed falls from the seed plate cell and is retained by the closed jaws of the point. The kernels fall into the space formed by the closed jaws and are ready to be planted in the next cycle. In-row and between-row spacing, as well as the straightness of rows, depend on the farmer's skill. Some jab planters have

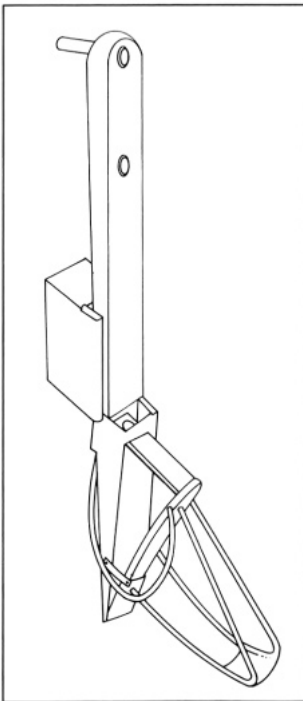

5.3. Jab planter.

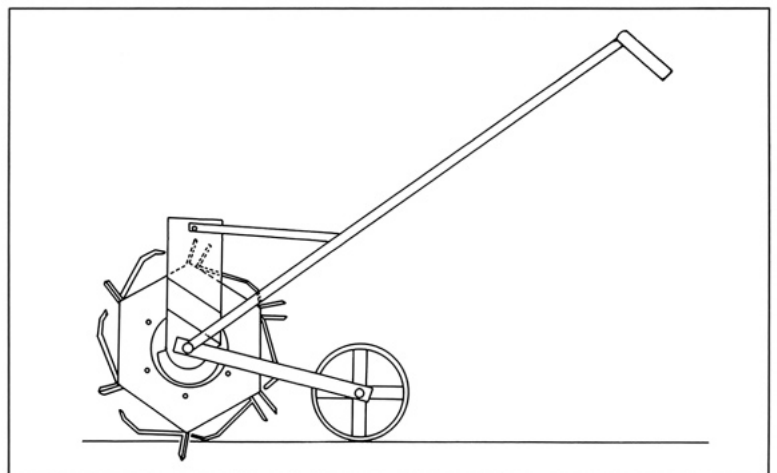

5.4. Rotary jab planter.

hoppers for both seeds and granular fertilizer so that fertilizer can be dropped along with the seeds.

The rotary or multiple jab planter essentially connects six jab planter mechanisms to a single seed hopper. As the rotary jab planter is pushed along the row, a cam opens and closes the jaws of the six points. Instead of having to carry the planter, the farmer pushes it along. The depth of penetration of the points depends on soil conditions and the weight of the planter. Frequently, it is necessary to add weight to the rotary planter in order to obtain proper penetration. A minor disadvantage of the rotary jab planter is that in-row spacing cannot be altered.

An animal-drawn ard is commonly used to form a furrow for seed. (In many societies, the seed is dropped into the furrow by a woman in the belief that seed planted by a female is more productive than seed planted by a male.) The plowman then covers the seed with the ard.

One-row planters that can be pushed by one person differ significantly. An example of a simple one-row planter is a wheel with a seed hopper at the hub. The seeds fall from adjustable holes as the wheel is pushed along the furrow. An example of a more sophisticated one-row planter is one that uses the same type of metering plate mechanisms used on animal- or tractor-drawn planters.

In India, multitube seed drills wherein three to six seed tubes direct seed behind a furrowing bar have been used for hundreds of years.¹ The seed tubes radiate from a single wooden bowl where the farmer's hand swirls the seeds into the seed tubes. These drills (illustrated in Fig. 5.5) can be used only on soil that has been plowed and harrowed.

An animal-drawn, one-row walking planter (shown in Fig. 5.6) has a simple steel frame and weighs about 50 kg. A sulky-type two-row planter weighs about 250 kg, excluding the weight of the tongue. Planters for tractors are either trailed machines very much like animal-drawn planters, integral units, or one-row tool bar-mounted trailing type units. The integral units are mounted on the tractor frame. The one-row trailing type units are more popular, since they fasten to a tool bar on the tractor's three-point hitch and can be easily adjusted for row spacing, being usually ground-driven. The trailing type is easy to mount and to use. One- and two-row planters of either the mounted or the trailing type use manual

5.5. Indian seed drill.

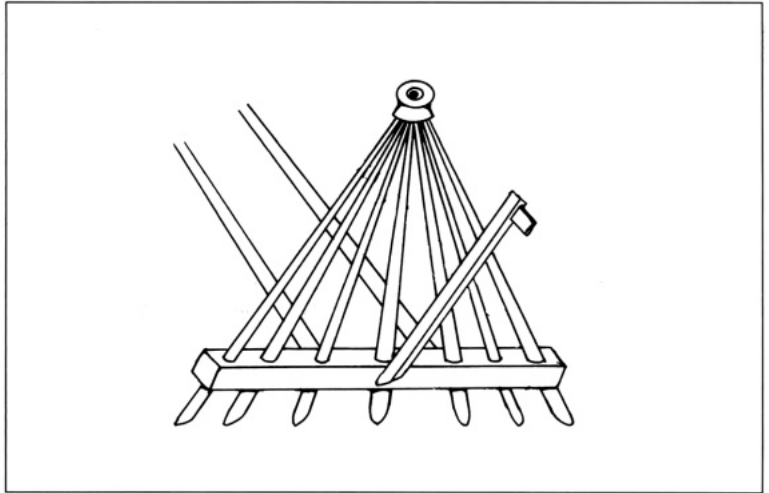

5.6. Animal-drawn one-row planter.

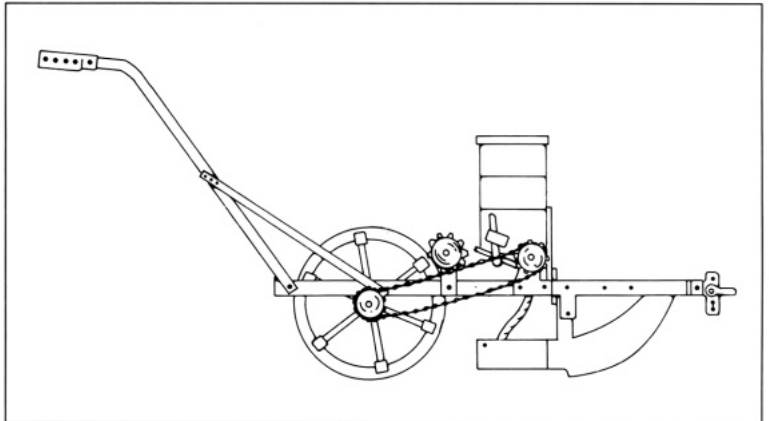

or hydraulic lift mechanisms. Multirow units are usually lifted with the tractor's hydraulic system.

The seed metering system separates one seed and delivers it to the seed-placing mechanism or furrow at a selected rate. If maize is being planted at the rate of 50,000 kernels/ha (20,000/acre) at an in-row spacing of 27 cm, in rows 75 cm apart and at a forward speed of 8 km/h, the seed metering system must select and drop a seed each eighth of a second. The seed plate system has been used for many years as the metering device for planting large seeds. For best operation, the seed plate requires seed graded according to size. Plateless seed metering systems utilizing mechanical pickup fingers, vacuum, or air pressure to meter the seeds are

gradually replacing the plate type planter because they can plant ungraded seed at high speed.

A typical air seed-metering device is shown in Figure 5.7. A fan pressurizes the air in the seed chamber, which is on one side of a rotating vertical seed disc. The air pressure differential between the chamber side and the outside of the seed disc holds one seed in each hole of the seed disc. At the point where the seed disc is to drop each seed into the seed tube, a roller or a sliding plate along the outside of the seed disc eliminates the pressure differential across the seed disc, and the seed falls down the seed chute into the groove made in the soil by the opener. The seed mechanism is usually placed as close to the soil as consistent with good design, for with a short seed tube the falling seed will be at a low velocity and will not bounce when it strikes the soil. Figure 5.7 shows a runner-type opener on the planter.

The no-till planter (Fig. 5.8) is actually a misnomer, since it cultivates the soil, preparing a 10-cm-wide strip just ahead of the planting shoe. A planter that is designed for planting on tilled soil will not operate satisfactorily on untilled soil;

5.7. Air seed-metering device.

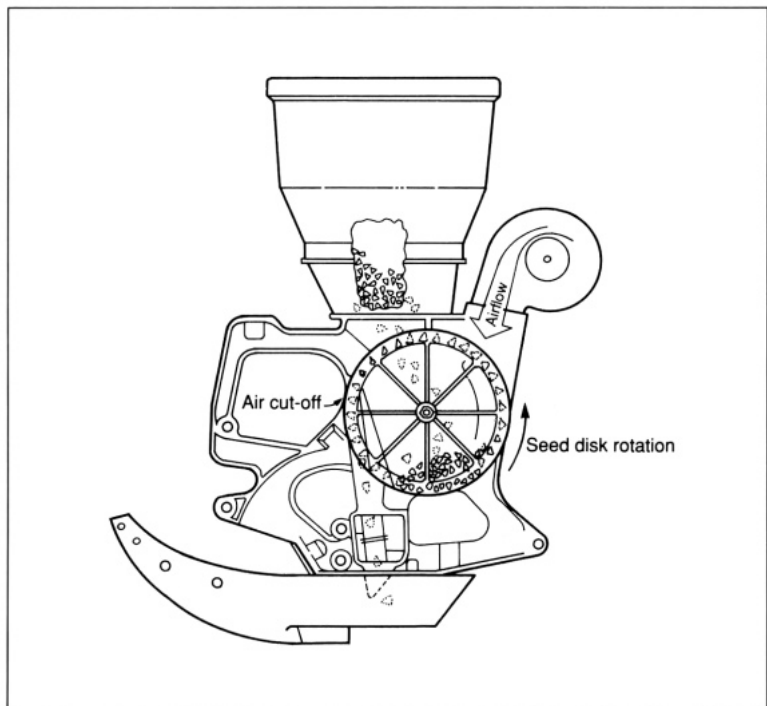

5.8. No-till maize planter.

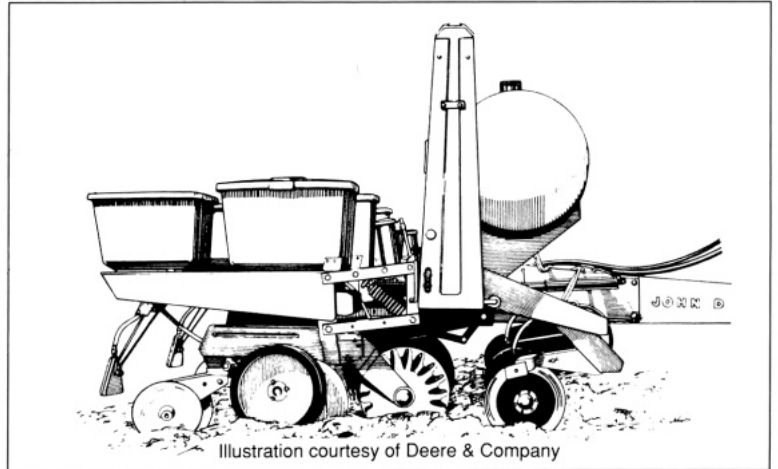

however, a no-till planter does a satisfactory planting job on both tilled and untilled soil. The functional elements of a no-till planter are shown schematically in Figure 5.9.

The *fertilizer opener* is usually the first soil engaging tool, because the fertilizer is positioned in front of the planter to place the heavy mass of fertilizer close to the tractor. Plain double-disc openers are generally used to make the slot for dry fertilizers, although single-disc or runner openers are sometimes used. Discs often perform better than runners. Discs can usually be set 5-15 cm the side of the seed row

Trash discs are mounted ahead of the tillage disc to push crop residue off the strip where the seed is to be planted. The absence of crop residue on top of the tilled strip makes for more uniform seed placement. In cool climates, the use of trash discs can also raise the soil temperature and enhance uniform seed germination.

The *tillage mechanism* tills the narrow strip of soil where the seed is planted. Fluted or ripple disc coulters are most common, although chisels or powered rotary tillers are used on a few designs. Disc coulters are usually 17 in (43 cm) in diameter and till to a depth of 10-13 cm. The fluted coulters till a 10-cm-wide strip, while the ripple coulters till a 2- to 4-cm strip. The ripple coulters require less down force than the fluted coulters. On hillsides, however, where the wider strip is an advantage, and on drier soil, the fluted coulters are better. The ripple coulters are best suited for use on wet, trash-covered soils. The fluted coulters tend to push residue down into the

5.9. Sequence of soil-engaging elements of a no-till maize planter. 1 = fertilizer opener, 2 = trash disc, 3 = tillage mechanism, 4 = seed opener and depth gauge, 5 = seed firming wheel, 6 = seed coverer, 7 = press wheel.

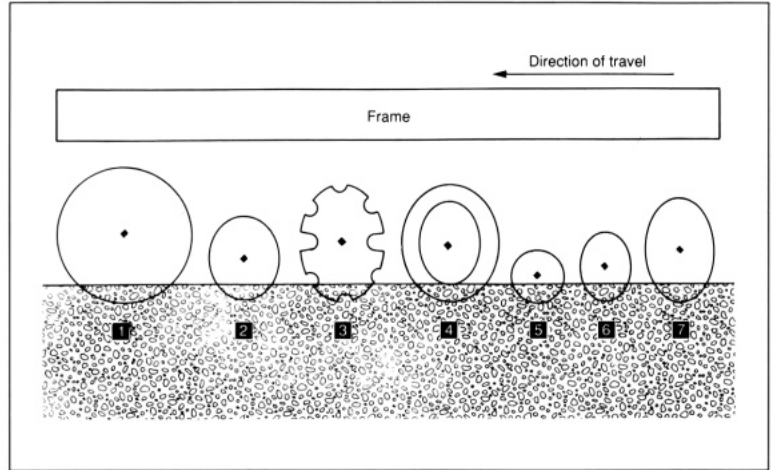

wet soil, thus minimizing good soil-seed contact. Chisels are the least costly mechanisms. Powered rotary tillers prepare a fine strip seedbed, but they are expensive must be powered, and have higher maintenance costs than other types of tillage mechanisms.

The *seed opener* is a conventional double-disc single-disc, or runner opener that can be used with planters for both plowed and tilled soil. The *depth gauge* is usually a rim mounted on the seed opener disc. Planting depth is the difference between the radius of the disc seed opener and the radius of the depth gauge rim.

The *seed firming wheel* is 15-30 cm in diameter and about 2 cm wide. The firming wheel presses the seed to provide good seed-soil contact before the seed is covered with earth. It cannot be used in sticky soils because the soil sticks to the firming wheel and moves the seeds out of position.

The *seed coverer* is either a disc or a blade. Its purpose is to cover the seed with fine soil particles. The *press wheel* then firms the soil on top of the seed. In a well-tilled seedbed, a seed-firming wheel is unnecessary, since the press wheel is sufficient. The press wheel is frequently designed to function both as a depth gauge and as a power source for individual crop planter units.

In addition to the parts of a large seed planter mentioned above, an *insecticide applicator* or *herbicide applicator* may be mounted in the rear and driven by the press wheel. A disc coultter on the end of an adjustable boom is often used as a

row marker, but this is often unsatisfactory in trashy conditions. A better method of marking rows is obtained by suspending a chain in front of the tractor. When the chain is kept over a previously planted row, the spacing is correct.

5.2 Tools for planting small seeds

Rice, wheat, sorghum, mustard, and alfalfa are examples of crops with small seeds. Broadcasting, drilling, and precision drilling are the methods normally used to plant small seeds. Dry, viable, ungerminated seed is almost always used for planting.

The principal exception is the direct seeding of wetland rice, where the soil is water saturated. Seeds require oxygen to germinate. Since a flooded ricefield is anaerobic, rice seeds must be soaked in water for about 36 h before planting to pregerminate them. If pregermination goes too far, the sprouts may be killed by being broken during planting. To plant pregerminated rice seed, the soil must be saturated to a soft mud consistency, but without pools of standing water. Good water control is essential in planting pregerminated seed.

Broadcasting is an ancient method of planting small seeds and can be done without equipment as shown in Figure 5.10.

5.10. Ethiopian farmer broadcasting wheat.



After the seed is broadcast, it is usually worked into the soil to obtain better seed-soil contact and thus better germination. The Ethiopian farmer covers the seed by an additional plowing with his beam ard. Sometimes a tree branch or a spike-tooth harrow is trailed behind a yoke of bullocks to work the seed into the ground.

A cyclone seeder is a manually powered centrifugal seeder powered by a hand crank or reciprocating bow to broadcast grass and other small seeds. Larger spinner-type centrifugal seeders can be mounted on a tractor's three-point hitch and powered by the PTO. Airplanes are sometimes utilized to broadcast seed onto large fields. If soil moisture and growing conditions are conducive to germination and growth, or if the terrain is difficult for ground equipment, no effort is made to cover the seed. Otherwise, the seed can be covered by passing a harrow over the field.

Weed control is often a problem in field planted by broadcasting, since mechanical weeding equipment cannot be used, and hand-pulling is too time-consuming. Planting by broadcasting therefore often requires chemical herbicides for weed control.

Small seeds can be planted in rows by dropping the seeds individually into a furrow made by a farmer with a hoe, by an animal-drawn ard, or by a simple multirow furrower drawn by an animal or tractor. The seed must be covered both to obtain good earth-seed contact and to protect it from birds. The seed is covered by a worker using his foot, by a hoe, or by an animal- or tractor-drawn plank or harrow.

The *grain drill* (Fig. 5.11) is the most common implement for planting small grain. Whether drawn by animal or tractor, drills are essentially the same. They consist of a box to hold the seed, a seed-metering device, furrow openers, a seed-covering device, and drive wheels to power the seed-metering device. Grain drills are differentiated by their number of furrow openers and the space between furrows. For example, a 27-7 drill has 27 furrow openers spaced 7 in (18 cm) apart. Thus it will seed a width of 15 ft 9 in (480 cm). Drills are available with furrow opener spacing of 6-14 in (15-35 cm). Fertilizer, grass-seeding, or no-till attachments can be added as options.

The seed-metering device must transfer seed from the seedbox to the coulter tubes at a fixed rate and yet be easily

5.11. Grain drill.

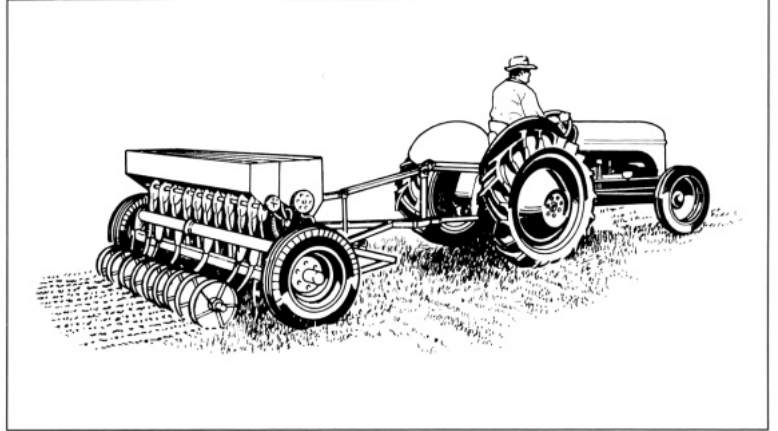

adjusted for a variety of grains. The number of individual metering devices should equal the number of coulters. The external force feed is one of the most common devices and works well over a wide range of seeds (Fig. 5.12).

The external force feed consists of a metal roller with a square bore and external flutes over half its length. Each roller fits into a feed cup, which is attached to the bottom of the seed box. A square shaft driven by the drill wheels extends through the fluted rollers and drives them in relation to ground speed. An adjustable gate regulates the size of the passage between the output side of the fluted roller and the drop tube to the

5.12. External force feed.

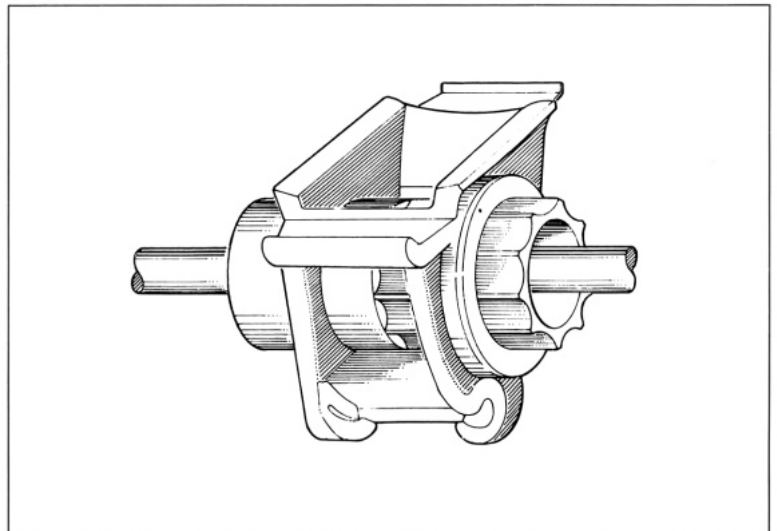

coulter. To adjust the rate of seeding, the fluted roller is slid axially on the square shaft so that the unfluted area exposed to the feed cup opening is increased or decreased. When the unfluted area is exposed to the opening, no seed will flow. When the fluted area is exposed, the seeding rate is maximized. Feed rate can also be adjusted by changing the gear ratio of the transmission between the drill wheels and the square shaft that drives the fluted rollers.

Another common seed-metering device on grain drills is the internal double-run feed (Fig. 5.13), which has a double flanged wheel, usually made of cast iron. One flange has coarse internal corrugations, while the other has fine corrugations. The wheel fits into a housing attached to the bottom of the seed box. The housing is designed so that by a simple adjustment, seed from the box can be directed into either the coarse or the fine side of the wheel. When planting small seeds, the fine side is used; the coarse side is used with large seeds. Sowing rate is adjusted by the speed of the wheel and the position of a gate between the point where the seeds drop off the internal corrugations and the outlet of the drop tube.

Another seed-metering device for grain drills consists of a soft polyurethane roller set against a glass or metal plate to wipe seeds one layer thick into a drop tube.

Pneumatic drills are made in widths up to 13.4 m (45 ft) and can be operated at high speeds while minimizing weight and mechanical complexity. A typical pneumatic drill consists

5.13. Internal double-run feed.

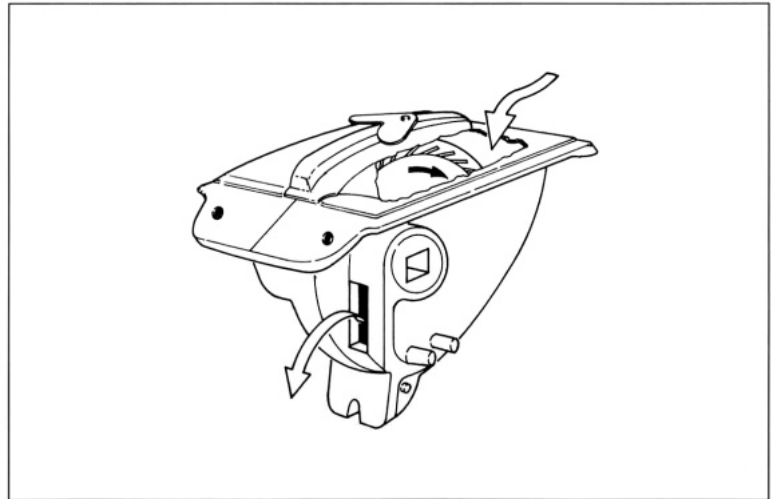

of a battery of fluted rollers, each feeding seed to a flexible air tube and coulter. A blower driven by the tractor's PTO provides air pressure to send the seed through the tubes and the coulters. Because of the velocity at which the seed strikes the furrow, depth is more difficult to control than with a slower drill, where seeds drop by gravity.

The *drum seeder* illustrated in Figure 5.14 provides a simple method of planting pregerminated rice seed in rows so that manually operated mechanical weeders can be used. A rotating drum containing the seed is the heart of the drum seeder. Around each drum are one or two rows of holes. Space between rows is determined by the axial distance between the rows of holes. When the holes are fully exposed, the seeder is set at its highest seeding rate. For a lower rate, a band is moved axially and clamped over a portion of each hole to restrict the flow of seed. As the seeder is pulled across the ricefield, the drums rotate and seeds fall out of the holes. The seed is not injected into the wetland field, but merely dropped on top of the mud. If there is a serious bird problem or danger of heavy rainstorms at planting time, the drum seeder should not be used.

The drum seeder is also used to plant upland crops such as mungbean, pea, and bean. Furrows are made with an

5.14. Eight-row drum seeder.

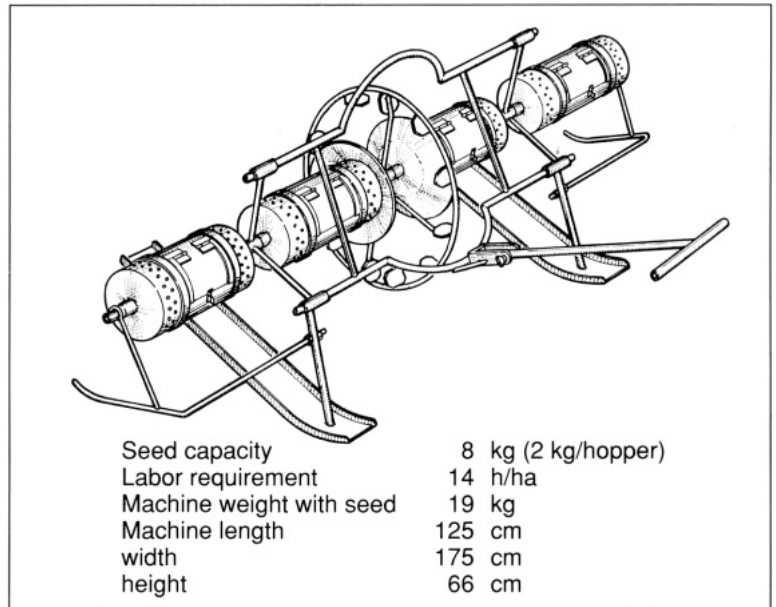

animal- or tractor-drawn furrower, and the drum seeder is pulled so the seeds fall into the furrows. The seed is then covered by foot or with a harrow. The drum seeder cannot provide exact spacing between individual seeds, but for many crops exact seed placement is not required.

The level of seed in the drum and the peripheral speed of the drum as well as the number and size of hole openings affect the seedling rate. For example, the number of maize kernels metered by a drum seeder with 15-mm-diameter holes and operating at a peripheral speed of 13 m/min varied from 100/rev when the drum was 80% full to 150 at 50% full to 240 when it was only 20% full. Thus, a simple drum seeder should be operated between about 1/3 and 2/3 full. With the seed drum 50% full, the seeding rate varied from 175 seeds/rev at a peripheral speed of 4 m/min, to 180 at 13 m/min to 115 at 22 m/min.²

Fluid drilling is a technique for planting small seeds. The seeds are mixed in a gel, which is extruded in the furrow like a ribbon of toothpaste. Since it is the gel that is metered in the row, the seeds cannot be placed with absolute precision. If the seeds are mixed with even density throughout the gel, however, the average number of seeds per unit of length can be satisfactorily controlled. The primary reason for fluid drilling is to improve the germination rate of vegetable crops such as Brussels sprouts. The seeds are first placed in a solution of water and salt so that a density difference separates the viable seed from the dead seed. The viable seed is then mixed into a gel. The gel may be simply made from wheat flour paste, and the planter can merely be a plastic cone used by cake decorators. For large-scale fluid drilling, many drills use a ground-driven peristaltic pump for each row unit.

Planning is very important when planting pregerminated seed or using the fluid drilling technique. Since the seed has begun to germinate, it must be planted within a day or two of the scheduled planting date. If a heavy rain or lateness of seedbed preparation prevents planting at the scheduled time, later planting is usually impossible, although some sophisticated fluid drilling facilities can store the pregerminated seed in cold (about 0°C) oxygenated water for several days.

Small seeds are sometimes pelletized so that they can be planted accurately with equipment designed for large seeds. Very small seeds such as petunia and small irregular seeds

such as carrot, sugar beet, and lettuce are encapsulated (pelletized) in uniform clay or sand spheroids about 3-5 mm in diameter. The technique consists of putting the seed into a rotating drum or oscillating pan, alternately wetting the seed with water (or a water-soluble binder such as sugar water), and dusting it with fine clay or sand. The result is a spheroid with a seed as its nucleus.

Single-seed planters (Fig. 5.15) are used to place seed in rows with identical distance between seeds. The planters use belts or discs with accurately spaced holes for holding one seed each. Unless clean, graded seed is used, a vacuum-type metering device is often required. These devices utilize an air pressure differential that holds one seed in each cell until the differential is zero. Single seed drills for planting small seed are usually made in one-row tool-bar mounted units that are ganged together for multirow planting. These planters are usually operated at 3-6 km/h when planting seed with a high germination rate. The seedbed must be well prepared in order to *plant to stand*, meaning that the plants are placed in the row with great precision to eliminate the need to fill in skips or chop out excess plants.

5.3 Tools for planting cuttings and tubers

Cassava (*Manibot utilissima*), also known as manioc, tapioca, yucca, mandioca, and guacamote, is grown for human and animal consumption in all tropical countries. Cassava normally produces seed, which enables plant breeders to develop varieties with specific characteristics. The general method for propagating cassava, however, is by planting stem sections that reproduce vegetatively. Stem cuttings are made

5.15. Single-seed planter with seed belt metering.

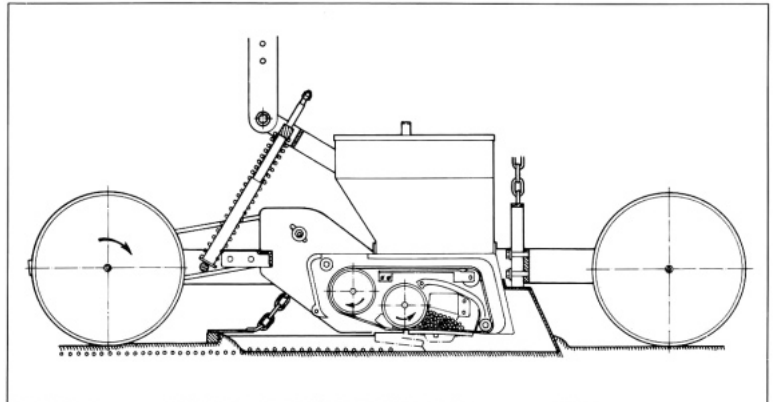

from plants at least 10 mo old. The stem cutting, called seed in some areas and stakes in others, are approximately 2.5-3.5 cm in diameter and 25 cm long. About 2/3 of the length of the cutting is inserted into the soil. Roots develop from the nodes under the soil, while new shoots emerge from the nodes above ground. In subsistence agricultural systems where cassava is planted on mounds, a short-handed hoe is used to prepare the seedbed and to plant the stake. In some areas, cassava is intercropped with maize, eggplant, or other vegetables. In others, it is intercropped with tree crops such as coconut, oil palm, or rubber.

Machine planting can be used if the cassava is planted on ridges or in rows on the flat. For optimum root production under a monoculture system, plant density should be 10,000-20,000 plants per hectare.³

The cutting angle of the stake and the position of the stake in relation to the soil surface affect the position of the roots, thus determining the success of mechanical harvesting. The effects that depth of planting, angle of cut, and planting position have on root distribution are shown in Figure 5.16. Root distribution and attachment can differ among cassava varieties.

Several cassava planters have been developed in Nigeria. One is a two-row, semi-automatic planter that simultaneously makes ridges and plants cassava stakes.⁴ The planter is carried on two land wheels and is attached to the three-point hitch of a category 1 tractor. Discs form the ridge, while an ingenious gripping device fabricated from discarded automobile tires

5.16. Effects of cutting angle and planting position on cassava root position.

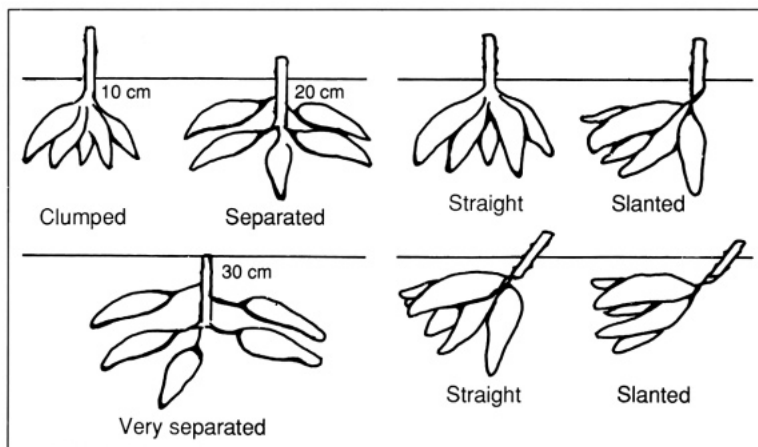

grips the cassava stake, places it in an upright position, and pushes it into the freshly formed ridge. Two men riding on the planter select stakes from a box and lay them onto the gripping devices, which are in the open position at the top of their cycles.

Another Nigerian cassava planter is two-row and fully automatic.⁵ The planter is drawn by a tractor and is capable of planting at speeds up to 10 km/h. Quality of stake placement, however, suffers above 6 km/h. The stake angle is affected by the speed of planting. The angle varies from 81° at 0.5 km/h to 45° at 6 km/h and 27° at 10 km/h. Stakes are 25 cm long. The machine requires a plowed, harrowed, level seedbed. Discs on the planter form ridges 7 cm high and 16 cm wide. The stakes are planted to a depth of 17 cm. The machine is designed to form a ridge around the cassava stake. Row spacing and plant spacing within the row are 90 cm.

Sugarcane (*Saccharum officinarum*) is sown by planting setts, which are short pieces of stem containing about three nodes. A sett is 2.5-5 cm in diameter and about 30 cm long. About 4-6 t of setts are required to plant 1 ha. The setts are laid end to end in furrows at about 1.5 m spacing and covered with 5-8 cm of earth. The goal is to produce a plant about every 60 cm in the row. Sugarcane can be grown from seed, but the seed has poor viability and thus is used primarily for breeding purposes. Semimechanized planting utilizes a plow to make the furrows and place the setts, which are covered with earth by hoes.

Mechanical planters that form a furrow with a middle buster are available. The setts then slide down a tube into the furrow, and disc coulters cover them. The setts are carried on the planter and fed into the planting tube by hand.

Pineapple (*Ananas comosus*), which is planted using crown cut from the tops of fruits, is planted in a fashion similar to that for sugarcane.

Potato (*Solanum tuberosum*) is propagated by planting small whole tubers or pieces of tubers each weighing 40-60 g. Each piece must contain at least one eye. Potato can also be planted from botanical seed—often referred to as true seed—but this method is used only for breeding work or in specific situations where it is not feasible to store tubers for seed. When botanical seed is used, the seed is usually planted in a nursery and the seedling transplanted in the field.

Tractor-drawn potato planters are usually two- or four-row units of either a trailing type or a semimounted type attached to the 3-point hitch of a tractor.

Potatoes are planted at a rate of approximately 1,500 kg/ha, so large seed hoppers are essential. A typical 4-row potato planter, as shown in Figure 5.17, weighs 6 t when the hoppers are filled with 1,500 kg of potato and 2,000 kg of granular fertilizer. Potatoes are normally planted at 90-cm (36-in) row spacing. Seed spacing in the row varies from region to region: 20-cm (8-in) spacing is common, but planters can be adjusted to provide a seed spacing of 10-50 cm.

Besides the frame and the potato and fertilizer hoppers, the important elements of a potato planter are the driving wheels, planting mechanism, and furrow openers. The driving wheels not only carry most of the weight of the planter, but drive the planting mechanism. The furrow is usually made by one pair of discs, while another pair covers the seed piece. The planting mechanism must select one seed piece from the seed hopper and drop it into a tube, which directs it to the furrow. There is one planting mechanism for each row.

Two types of potato seeding devices are used as planting mechanism. The more common device is the picker pin mechanism (Fig. 5.18). This is a vertical wheel with six to eight picker pins attached to the circumference of the wheel. Each pin on the wheel jabs and holds a seed piece as it sweeps

5.17. A 4-row potato planter.

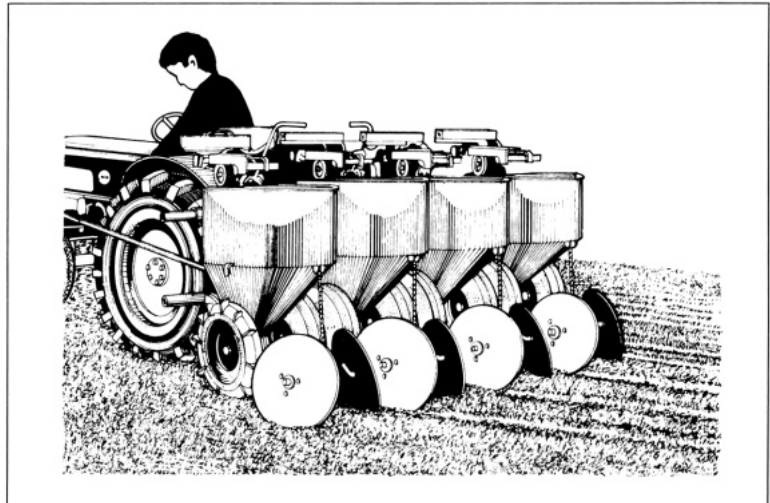

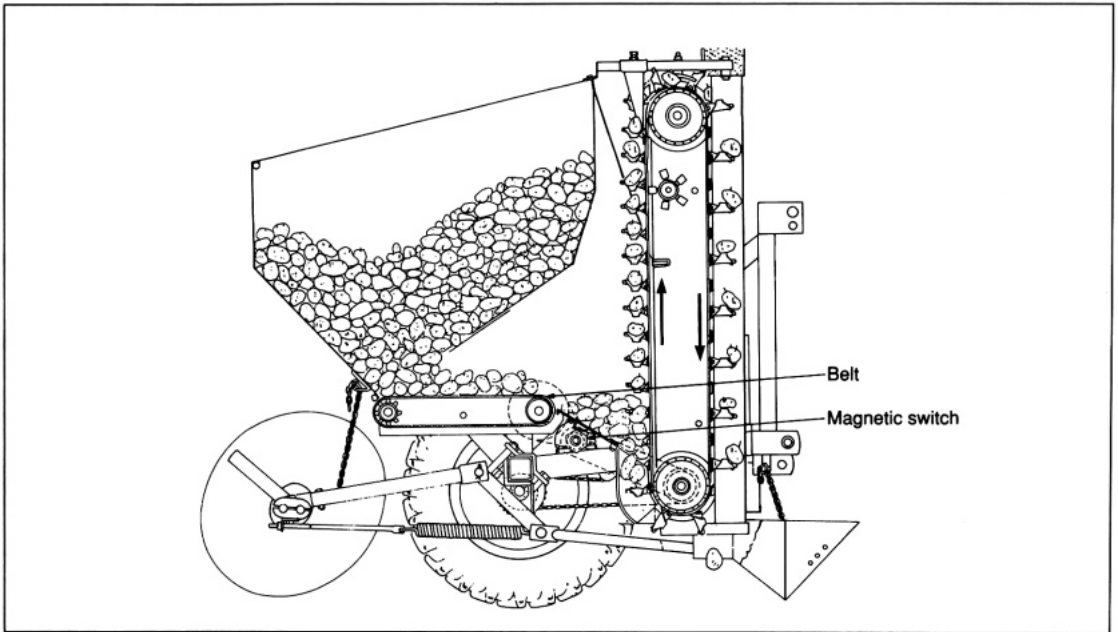

5.18. Potato planter using picker pins.

through a trough. At a discharge point above the seed chute, a cam-actuated finger pushes the seed piece from the pin. The seed chute directs the seed piece to the furrow.

Seed cups are also used as a seed-metering device (Fig. 5.19). Seed cups are attached to a chain driven by one of the driving wheels. Seed pieces fall into the cups as they sweep past the bottom of the seed hopper. Excess seed pieces are shaken from the cups. At a point above the seed chute, the chain goes around a sprocket, and the seed piece falls from the cup. The seed cup mechanism is usually preferred when planting whole tubers.

Planting tests using cut seed at 8.6 km/h in level loamy sand, with the planter set at a spacing of 46 cm, revealed that the picker pin machine had an average spacing of 46.5 cm for single seeds with a coefficient of variation of 31%. The seed cup machine obtained an average spacing of 45 cm with a coefficient of variation of 36%. The planter with the picker pin mechanism had better uniformity of seed placement: 82% of the placements contained a single seed piece, 8% contained doubles, and 10% no seed.⁷ The planter with the cup-type mechanism placed a single seed piece in 72% of the placements, doubles in 23%, and no seed in 5%.

5.19. Potato planter using seed cups.

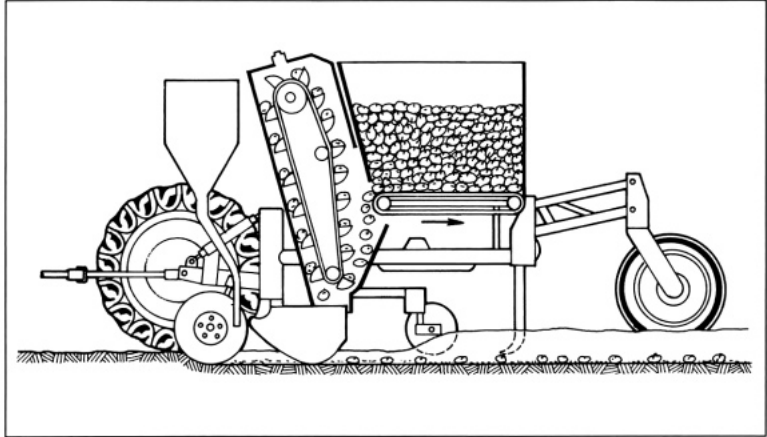

5.4 Tools for planting seedlings

There are two major groups of transplanters: those used to plant vegetable plants in upland soils and those used to plant rice seedlings in wetland fields.

A transplanter for vegetables is essentially a cart carrying the plants, with a furrow opener, a water tank, and soil-firming wheels. Most vegetable transplanters are two-row machines with two operators, since one person is needed to feed the plants into the mechanism for each row.

The operator selects a plant and places it into a pocket attached to a conveyor chain. This transports the plant to the furrow made by the furrow opener. Plant pockets are attached to a wheel on some transplanters. The plants are placed in the pockets at the top of the wheel's rotation; spring-loaded rubber grip hold the plant; and a cam-actuated device opens the grips and drops the plant into the furrow at the bottom of the wheel's rotation. The cam that actuates the gripping device also opens the water valve so that water flows into the furrow. The firming wheels firm the soil around the plant as well as power the transplanter's drive mechanism.

Most rice transplanting throughout the world is done by hand. In industrialized countries such as Japan and Taiwan, however, mechanical transplanters are used. For a mechanical rice transplanter to perform well, the field should be level and puddled to a soil consistency that will hold the plants. Unlike mechanical transplanters, humans doing manual transplanting are able to make allowances for irregularities in the field.

Production of rice seedlings is a very important part of transplanting. More care is required in producing the seedlings for machine transplanting than for manual transplanting, since the seedlings must be of a specific density and height for placement in trays suitable for the transplanter. A study in the Philippines revealed that preparation of seedlings for transplanting into 1 ha of wetland field required 23.2 man-hours for hand transplanting, 46 man-hours for manual machine transplanting, and 35.8 man-hours for power machine transplanting.⁸

In hand transplanting, the farmer spaces the seedlings on a 20- x 20-cm grid. A line marker resembling a rake with 20 teeth set on 20-cm centers is pulled across the field to mark the rows. The farmer plants the seedlings at a 20-cm spacing in the row. In a well-prepared field, water depth during transplanting is about 1 cm.

A typical manual transplanter is made of wood and steel and is pulled by the farmer. The machine shown in Figure 5.20 transplants six seedlings simultaneously and has a transplanting arm, six grasping forks, a wooden float board, and a seedling tray. Seedlings are arranged in layers with the stems parallel and the roots in contact with the surface of the

5.20. Manual rice transplanter.

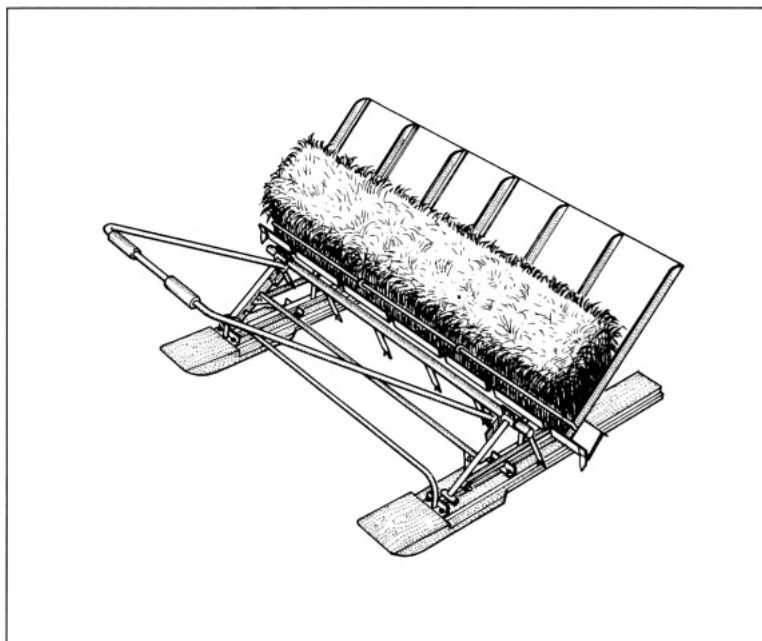

tray. A wooden plank presses the seedlings downward and maintains their positions as they are removed from the tray during planting. The transplanting arm is part of a bar linkage on which six pairs of seedling pickers are mounted at equally spaced intervals. As the transplanting arm moves up and down, the bar pushes a swing arm. The swing arm actuates a pawl and movable ratchet, which slides the seedling tray laterally to assure that seedlings are taken uniformly from all parts of the tray. Two people work with the machine; one arranges seedlings in the tray while the other operates the transplanter.

To actuate the machine, the farmer pulls the transplanter handle backward to its maximum limit. This action opens the seedling pickers. Next, as the handle is pushed downward through the feeding frame slots, each pair of picker fingers takes a small cluster of seedlings. The picker fingers continue down into the soil to a depth of 2-3 cm. The seedlings are released from the picker fingers by pulling the handle upward. The farmer then steps backward one row and repeats the same movement.

A 6-row manual transplanter is about 1.25 m wide, 90 cm long, and 65 cm high. It weighs about 20 kg empty; it requires a draft of 7-11 kg (69-108 N, 15-25 lb) when the field is flooded, and 10-13 kg (98-128 N, 22-30 lb) when it is dry. Travel speed depends on the farmer's stamina, but is usually about 0.6 km/h.

Most engine-powered rice transplanters are pedestrian units. Some larger units are designed for mounting to the three-point hitch of a farm tractor. These units carry an operator to assist with the trays of seedlings. Planting depth and distance between plants can be adjusted. The transplanter has a 3-hp, 4-cycle gasoline engine and is controlled by the operator walking behind the machine. It consists of transport, feeding, and planting components, as well as the engine. The transport-propulsion component is equipped with two steel wheels and a plastic float. It is attached to the body through a linkage mechanism. Seedlings are placed on an inclined aluminum tray and gravity-fed to the planting forks. The seedling tray moves reciprocally from side to side to assure that a uniform quantity of seedlings is picked up by the planting fork during each stroke.

The planting fork removes seedlings from the seedling board in small clusters. A cam inside the planting mechanism energizes the fork to grasp and hold the seedling cluster as the fork traverses the seedling tray. The fork releases the cluster in an upright position into the soil.

A typical power transplanter has a 3-hp gasoline engine. It is 200 cm long, 90 cm wide, and 90 cm high, and weighs 80 kg. The transplanter plants 2 rows at 30-cm row spacing. The operator guides the transplanter by a pair of handles as he walks behind it. Working speed is about 2 km/h.

Table 5.1 compare methods of transplanting rice.

Table 5.1 Comparison of rice transplanting methods.⁹

Method	Hand transplanting	Manual transplanter	Power transplanter
Time for seedling preparation (h/ha)	23.2	46	35.8
Time to transplant (h/ha)	80-160	49.7	20.2
Total time (h/ha)	143.2	95.7	20.2
Row spacing (cm)	20	20	22-24
Seedling space in row (cm)	20	19-36	17-21
Missing hills (%)	0	7.5	6
Floating hills (%)	0	0	3
Planting depth (cm)	3	9	5
Plant population (no./m ²)	25	19	22
Estimated grain yield (t/ha)	4.1	3.8	3.3

REFERENCES CITED

1. Steensberg A (1971) Drill-sowing and threshing in Southern India compared with sowing practices in other parts of Asia. *Tools Tillage* 1(4)
2. Shein T (1988) Evaluation of different metering devices for multi-crop seeding. MS thesis, University of the Philippines at Los Baños, Laguna, Philippines. 80 p.
3. De Vries C A (1978) New developments in production and utilization of cassava. *Abst. Trop. Agric.* 4:89.
4. Branch D S, ed. (1978) *Tools for homesteaders, gardeners and small scale farmers.* Rodale Press. 233 p.
5. Odigboh E V (1978) A two-row automatic cassava cuttings planter: development, design and prototype construction. *J. Agric. Eng. Res.* 23:2
6. Prairie Agricultural Machinery Institute (1978) Evaluation report no. E1077 on the McConnell model 555 potato planter. Humboldt, Saskatchewan.

6 Fertilization

The dispersal of animal manure on cropland serves two purposes. First, it is a means for disposing of the manure generated by animals kept in confinement. Second, manure is valuable as a fertilizer because it contains elements required for plant growth.

In nonmechanized agricultural systems, where both herders and farmers live side by side, a symbiotic relationship often develops in which the herders graze their cattle on crop stubble. The herder thus receives forage for his cattle, while the farmer receives fertilizer. An example of this relationship exists in Nigeria between Fulani herders and farmers from other tribes,

In Ethiopia, dry cow dung is taken to fields coming out of fallow, where it is mixed with dry turf to form piles about 1 m in diameter and 0.5 m high. The mixture is then burned, and the ashes are scattered over the field. This practice provides a flush of growth during the first cropping season.

Cow dung is also formed into cakes and burned as fuel - a common practice in India and Nepal. A more beneficial use of the dung requires capital investment. First, the animal manure is put into a methane digester. The resultant biogas can be used as fuel for cooking and light. Second, the fields are fertilized with the manure effluent. Not only does the methane digester allow the farmer to utilize animal manure for fuel and fertilizer, but the process prevents the production of disagreeable odors.

Means of applying both animal and chemical fertilizers are discussed in this chapter.

6.1 Rate of manure production by animals

When manure consists of dry matter of 12% wb or less, it is called liquid manure. When the dry matter is 16% or more, it is called semisolid. Manure that is only 12-16% dry matter is often difficult to handle by mechanization, since it is too viscous for liquid manure handling equipment and too fluid for semisolid manure handling equipment.

In many types of animal husbandry, straw, woodchips, sawdust, and maize stover are used for bedding. A water flush system is sometimes utilized for manure removal in dairy barns where the temperature does not fall below freezing for extended periods. The amount of manure that must be spread on the fields usually exceeds the amount of feces and urine the animals produce. In nonliquid manure systems, bedding absorbs urine and thus captures nutrients that would otherwise be lost.

The amount and composition of animal feces vary with the animal and the amount and composition of the feed. Table 6.1 shows manure production without litter or bedding for some common domestic animals.

Table 6.2 gives the storage requirements in the northeastern United States (temperate climate) for a dairy cow weighing 1350 lb (613 kg).

6.2 Hand tools for applying manure

Human excreta (night soil) has been used as fertilizer in the Orient for more than 30 centuries. Night soil is stored in stoneware or concrete-lined pits, and carried to the field in pails attached to carrying poles or in barrels. It is then applied with a ladle made of a bowl of galvanized sheet steel with a bamboo handle about 2 m long. The ladle weighs about 1 kg and holds 4-5 liters. It is light and inexpensive, but needs to be repaired after 2-3 mo.

A water-carrying bamboo tube is sometimes used in place of a bucket and ladle to distribute night soil (Fig. 6.1).¹ The tube is about 13 cm in diameter and 80 cm long. It weighs about

Table 6.1. Manure production per 500 kg of animal liveweight.

	Horse	Cow	Heifer	Steer	Swine	Sheep	Laying hen
Raw waste (kg/d)	22.5	41.0	42.5	44.9	32.5	19.9	26.4
Feces:urineratio	4	2.2	1.2	1.8	1.2	1	—
Density(kg/m ³)	—	1005	1005	1010	1010	—	1050

Table 6.2. Storage requirements for manure of a dairy cow weighing 1350 lb (613 kg).

Form to be stored	Storage/cow per d	
	m ³	ft ³
Semisolid, under roof	0.047	1.65
Semisolid. in nonroofed building	0.051	1.80
Liquid, in open-top tank	0.057	2.00
Liquid, in earthen lagoon	0.070	2.50

1 kg and holds about 13 liters. Two tubes are carried on a carrying pole. The night soil is distributed by pouring from the end of the tube. A night soil tube has a service life of about 1 yr.

6.3 Machines for spreading manure

In a mechanized system, manure spreaders are used for transportation and distribution. The mechanical manure spreader, a wagon with a mechanical means to distribute manure, was invented about 1865.² The unloading and distributing mechanisms of small manure spreaders are powered by the rear wheels. Large manure spreaders are usually powered by the tractor's PTO. Manure spreaders are grouped into three types: box, flail, and closed-tank spreaders.

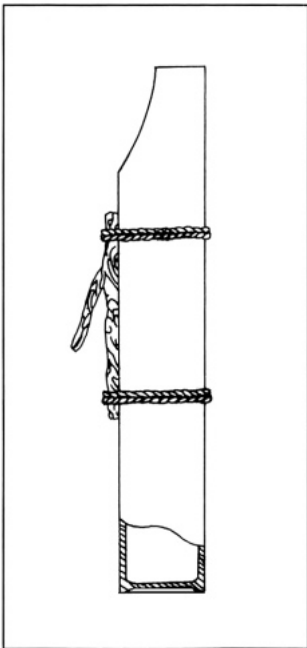

6.1. Night soil tube.

6.3.1 Box spreaders. The box-type manure spreader (Fig. 6.2) is used for manure containing enough bedding to be piled in a heap. Small box spreaders are driven by the rear wheels. For this reason, the drive tires are mounted backwards relative to the drive tires on a tractor. On a ground-driven manure spreader, the V of the tire's tread points rearward instead of forward. Animal-drawn spreaders are four-wheeled units. Tractor-drawn spreaders are usually of a two-wheel trailer design.

A conveying chain at the bottom of the spreader's box moves the manure to the beaters. Box-type manure spreaders that unload at the front have been manufactured, but these machines have not been generally accepted. Today, box-type manure spreaders are unloaded at the rear. From one to three beaters are used to distribute the manure. In the three-beater

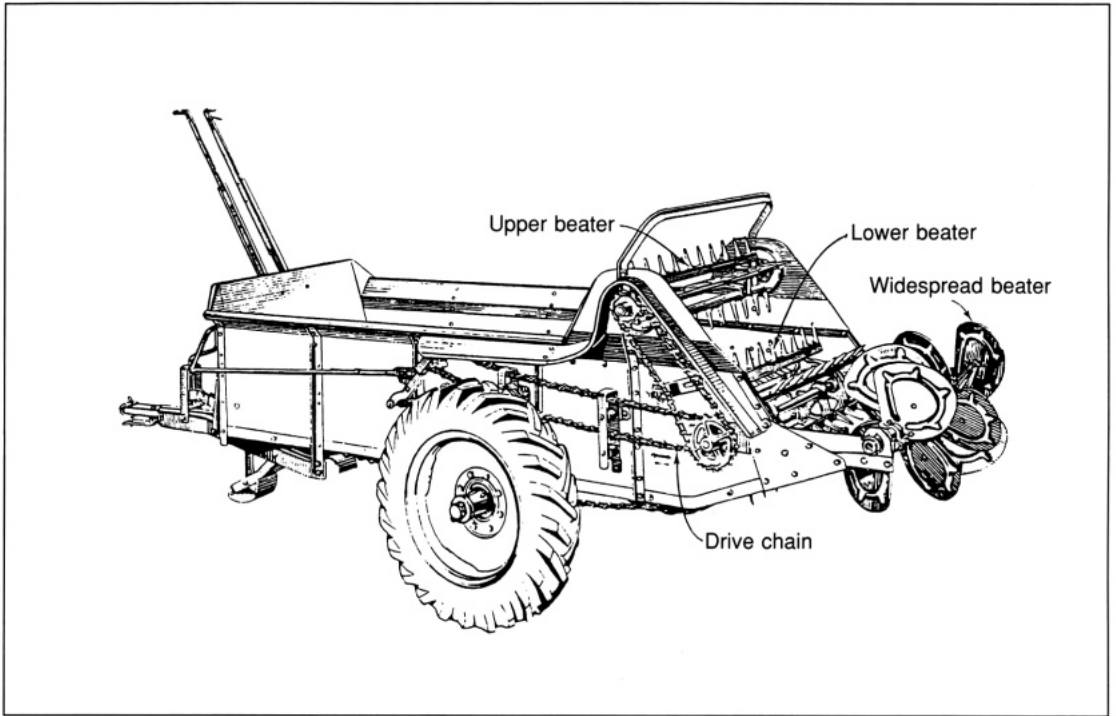

6.2. Box-type manure spreader.

system, two opposed action cylinders—usually with spike teeth—tear and shred the manure. The cylinders throw shredded manure onto the widespread beater, which flings it rearward and to the sides to make an even swath about 6 m wide. The three beaters are most useful when spreading caked manure or manure containing a high proportion of bedding. When manure contains less bedding and is spread daily, a single widespread beater is sufficient.

A few PTO-powered box manure spreaders use powered swinging flails—similar to those of a rotary tillage machine. The unit distributes the manure evenly but does not make as wide a swath as a three-beater spreader.

When using a box spreader to haul and distribute semi-solid manure, a solid endgate is put in front of the beaters so the manure will not ooze out under them during transport. While spreading manure, the endgate is raised to allow the manure to contact the beaters.

The ASAE allows two methods of calculating volume for manure spreaders. The *heaped load method* assumes that manure can be heaped up to 38 cm above the topmost beater.

This is possible only if the manure contains a good deal of bedding such as straw. The *struck level method* of calculating volume is more realistic. It is simply the volumetric capacity of the box while the heaped load is volume A + B of Figure 6.3.

Ground-driven box spreaders range from 2.5 to 3.5 m³ (70-100 bushels) heaped-load volume. PTO-powered box spreaders range up to 17.5m³. The larger PTO-powered spreaders either have dual axles to obtain sufficient flotation or are truck-mounted.

A small PTO box-type spreader requires an average of 10-14 PTO hp for the unloading cycle, but there may be peaks as high as 45 hp at the initiation of unloading. A large (12.5-m³) PTO box spreader requires an average of 15-20 hp for the unloading cycle.

Some box manure spreaders use a pushing board or piston instead of a slatted chain conveyor to move the manure rearward. A winch and cable or a hydraulic cylinder may be used to move the pushing board.

6.3. Volumetric capacity of box-type manure spreaders.

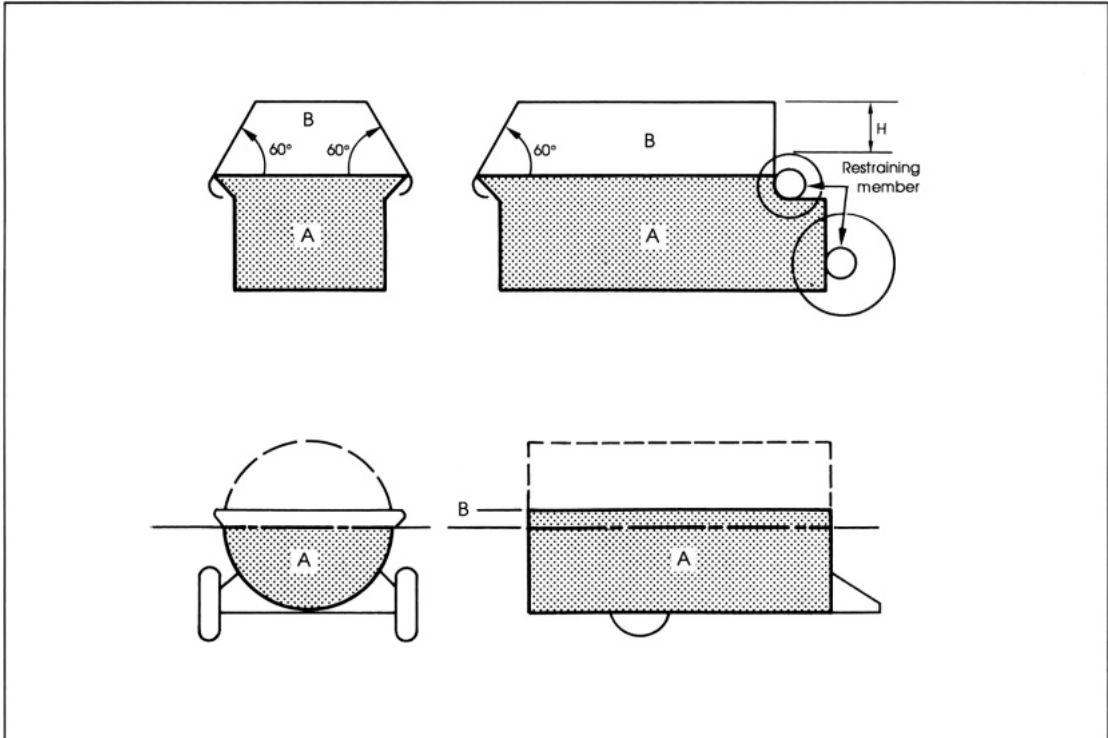

6.3.2 Flail spreaders. Manure with little bedding (semisolid) is easily transported and spread with a flail spreader. All flail spreaders are powered by the tractor's PTO. The design is simple. The flail spreader consists of a cylindrical tank with a powered shaft along the horizontal centerline of the cylinder, as illustrated in Figure 6.4. Chains fastened to the shaft fling the manure out from an opening in the side.

A flail spreader requires more power than a box-type spreader of identical capacity. Flail spreaders from 5 to 12 m³ capacity require an average of 15-47 hp for the unloading cycle, with peaks of 60-80 hp.

6.3.3 Closed-tank spreaders. Liquid manure is usually transported and spread from closed-tank manure spreaders. These spreaders are essentially tanks — cylindrical, but sometimes rectangular — that are pumped full of liquid manure. The manure is discharged through a nozzle by gravity, air pressure, or pumps for a 10-12 m swath. Alternately, it can be discharged through injection shoes. The volume of closed

6.4. Flail-type manure spreader.

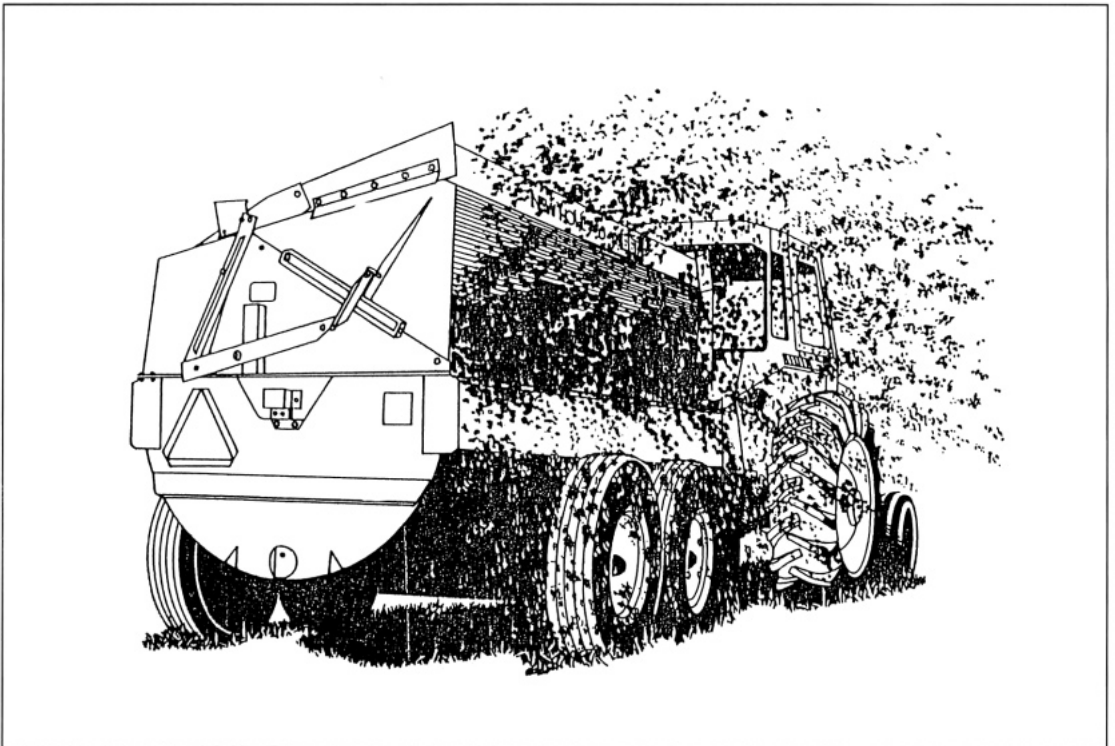

tank spreaders is the internal volume in liters or U.S. gallons (ASAE Standard 5326).

Liquid spreaders range from 3,000 to 20,000 liters capacity. Large tires are required for flotation because of the weight, and a large tractor is required to control the unit on irregular terrain. For example, an 8,000-liter (2,100-U.S. gal) spreader weighs 8 t when loaded.

6.4 Machines for applying chemical fertilizer

Nitrogen, phosphorus, and potassium (N, P, and K) are the principal fertilizing elements. Other elements such as zinc, boron, and molybdenum are sometimes required in small amounts and are referred to as trace or micro elements. Nitrogen, phosphorus, and potassium are found in animal manure and organic fertilizers. Chemical fertilizers containing purer, concentrated forms of N, P, and K are manufactured in factories. Although most K in the form of potash (K_2O) is mined from natural deposits. The weight of each of the major ingredients of a commercial fertilizer is described by the percentage by weight of N, P (P_2O_5), or K (K_2O) in the fertilizer. For example, an 80-lb bag of 5-10-10 fertilizer contains 4 lb (5%) of N, 8 lb (10%) of P_2O_5 , and 8 lb (10%) of K_2O ; the remainder is inert material.

Lime is not a fertilizer but is often added to the soil to lower soil acidity (increase soil pH), creating more favorable growing conditions for plants such as maize and alfalfa. Likewise, sulfur is added to the soil to increase acidity for crops such as blueberries.

Throughout the world, N, P, K, and acidity ameliorants such as lime are applied in the form of dry pulverized rock, crystals, or uniformly shaped spheroids called prills. Anhydrous ammonia (NH_3) is 82% N but is gaseous at normal temperature and atmospheric pressure. In countries where NH_3 is inexpensive, however, it is injected into the soil as a pressurized liquid.

Liquid fertilizers, in which the elements are dissolved in water, are easy to formulate for specific applications. They lend themselves to precise metering and easy handling by pumps. Large volumes of water must be transported, however. In application systems where it is advisable to reduce the amount of water to be transported, fertilizing elements are suspended in water and mixed during transport to the field. These liquid fertilizers are called *suspensions*.

Irrigation systems are sometimes equipped to place chemical fertilizer into solution and distribute the solution in the irrigation water.

6.4.1 Dry fertilizer. The simplest method of applying dry fertilizer is by carrying a container of fertilizer in one hand and broadcasting it with the other. This is the most common method of applying chemical fertilizer to the ricefields of Asia. For upland row crops, fertilizer is dribbled by hand alongside the rows.

Hand application has an advantage in that it requires no investment for equipment; however, there are several drawbacks. The fertilizer cannot be applied with precision, nor is it placed in the root zone of the plants, where it would be utilized most efficiently. There is a health danger for the applicator in that concentrated nitrogen fertilizers such as urea can be absorbed through the hands, displacing oxygen in the blood with nitrogen, causing the applicator to become faint and disoriented, and to breathe laboriously. If one is broadcasting chemical fertilizer by hand, a hand scoop should be used.

A manually operated seed fiddle or cyclone seeder in which the fertilizer drops onto a spinning disc that distributes it by centrifugal force about 200° to the sides and in front of the operator does a satisfactory job of broadcasting granular fertilizer on small fields. For lawns and smooth gardens, the push-type spinner fertilizer distributor does the same job. Unfortunately, many pieces of lawn and garden equipment have such small wheels that they are difficult to push or pull, and they often tip over when used on rough ground.

In ricefields, about 70% of the nitrogen fertilizer (urea) broadcast onto the water is lost before it gets into the plant. By placing urea in the root zone, 5 cm below the soil surface, it is possible to reduce the loss to 40%. Urea is difficult to meter in humid climates, since it absorbs moisture and tends to form lumps.

A manually powered push-type fertilizer applicator (Fig. 6.5) utilizes both an auger and a plunger to inject urea 5 cm deep into the flooded ricefield. The machine must be used on level fields with no deep water. Although tests reveal that the machine provides a 40% increase in fertilizer efficiency,³ it has not been widely accepted by farmers in Southeast Asia;

the price of the machine plus an application time greater than that of hand broadcasting have prevented most farmers there from using fertilizer injectors, although the machines utilize fertilizer more efficiently than does hand broadcasting.

Because fertilizer is corrosive, hoppers, metering mechanisms, and chutes must be made of anticorrosive materials such as plastics, rubber, stainless steel, or fiberglass.

Fertilizer is quite often applied 5 cm to the side of the plant row and also 5 cm below the surface when planting seeds such as maize in rows. The fertilizer attachments for animal- and tractor-drawn planters are usually powered by a ground-driven wheel. Dry commercial fertilizer is applied by chain-and-sprocket combination for the metering drive, by adjustable orifice openings, or by both. A good fertilizer distributor

6.5. Plunger-auger fertilizer injector.

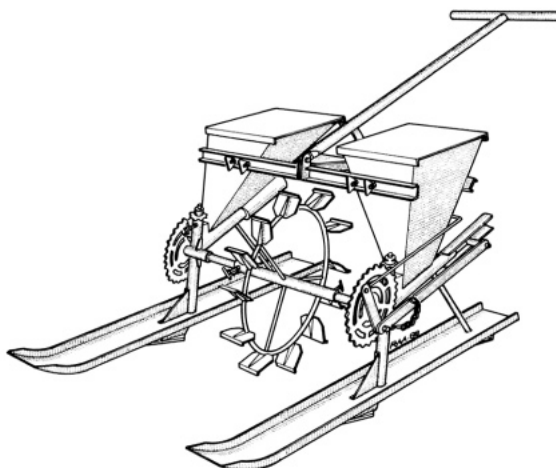

Power	- 1 person
Gross weight	- 12 kg
Machine length	- 1.7 m
Machine width	- 0.5 m
Fertilizer capacity	- 4 kg urea
Application rate	- 50 to 200 kg/ha
Work rate	- 0.5 ha/d
Labor requirement	- 16 labor-h/ha
Swath width	- 4 rows
Plant row spacing	- 15-22.5 cm
Injection depth	- 4-5 cm
Maximum water depth	- 0.5-5 cm
Application time	- 1-4 wk after transplanting

should be able to provide uniform distribution at rates of 100-2000 kg/ha.

Most commercial fertilizer is applied by broadcasting. Animal-drawn, ground-driven, or tractor-mounted, PTO-driven spinner-type applicators are simple and inexpensive. They can provide even coverage if care is taken not to overlap adjacent swaths. One-spinner units are more common than two-spinner units (Fig. 6.6).

The simple drill-type box spreader, in which an agitator at the bottom of the hopper moves granular fertilizer through adjustable holes, provides even application. Its main disadvantage is that it is restricted to widths of 1.8-3.5 m (6-12 ft) because of gates and highway regulations.

Pneumatic fertilizer distributors provide wider swaths for dry fertilizer—up to 10-12 m. The fertilizer is metered from a central hopper into flexible tubes. A fan blows the fertilizer toward deflection plates (nozzles), which distribute the fertilizer. The advantages of pneumatic distributors are that they provide the metering accuracy of the drill-type distributor, the swath width of the spinner-type distributor, and narrow transport width. Disadvantages include the expense of increased power and the need for a more complex mechanism.

Grain drills and maize planters usually have options for a fertilizer applicator so that planting and fertilization can be combined (Fig. 6.7). When only a small amount of commercial fertilizer needs to be applied, the drill or planter with a fertilizer applicator is a time saver. If large amounts of

6.6. Spinner-type fertilizer distributor.

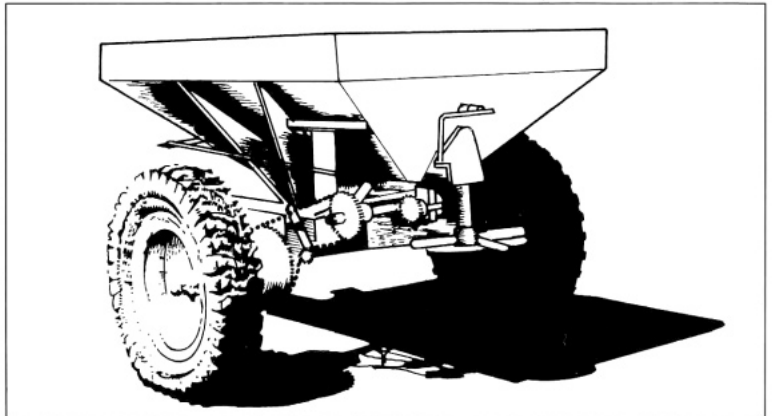

fertilizer are needed, however, it may be better to apply fertilizer in a separate operation so that the time for planting is not extended.

6.4.2 Liquid fertilizer. Liquid fertilizer is easily handled mechanically by pumps or gravity, and the rate of application can be accurately controlled by nozzles and valves. Liquid fertilizers are classified into two groups—high pressure liquids such as anhydrous ammonia (NH_3), and low pressure liquids such as aqua-ammonia and mixed liquid fertilizer.

Ammonia is 82% nitrogen. It is a gas at normal temperature (its boiling point is -181°C at sea level). It is stored as a liquid by pressurizing it at about 1,725 kPa (250 psi). The vapor pressure of the gas above the liquid in the tank is utilized to force the liquid NH_3 through the metering gauge and the applicator knives. As the pressure on the liquid NH_3 is reduced to atmospheric, it flashes into gas and is injected under the soil. Figure 6.8 shows a tractor-mounted NH_3 applicator.

Ammonia is attracted to water, so as long as there is some moisture in the soil at the point of injection, the NH_3 will cling to the soil moisture. Its affinity for moisture makes NH_3 dangerous if not handled carefully. Ammonia equipment such

6.7. Drill-type fertilizer distributor.

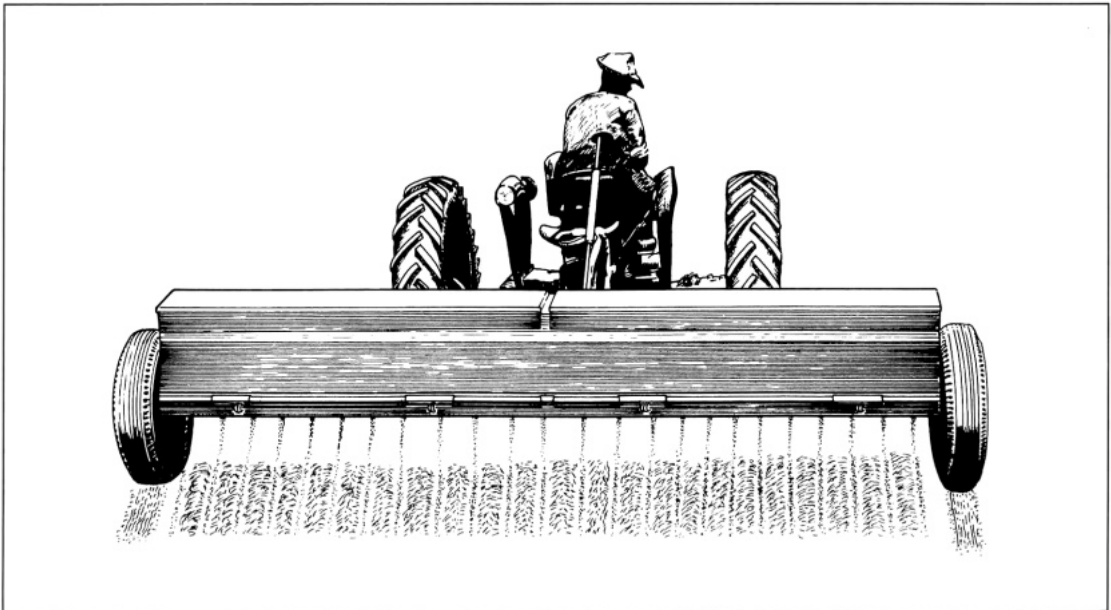

as tanks, gauges, hoses, and applicator knives must be in good condition. Operators should wear proper safety goggles and have wash water available in case of a spill. In spite of its liabilities, NH_3 is an inexpensive form of nitrogen fertilizer in many countries, because it is easy to apply. By dissolving a nitrogen source such as NH_3 or urea in water, a solution containing 20-25% nitrogen is obtained. The maximum amount of NH_3 that can be dissolved in the water depends on temperature. Aqua-ammonia has an advantage in that it is less hazardous than NH_3 , and it requires simpler equipment. Like dry fertilizers, where 2/3 of the weight is inert material, 3/4 of the weight of aqua-ammonia is water. Aqua-ammonia can be metered by a ground-driven peristaltic pump.⁴ Figure 6.9 shows an aqua-ammonia injector for wetland rice.

In applying nitrogen fertilizer to the root zone of wetland rice, pumps using aqua-ammonia have an advantage over mechanical injectors applying dry urea, since the injection tube of the peristaltic pump machine does not get clogged with soil. Also, the physical characteristics of the solution do not

6.8. Tractor-mounted anhydrous ammonia applicator.

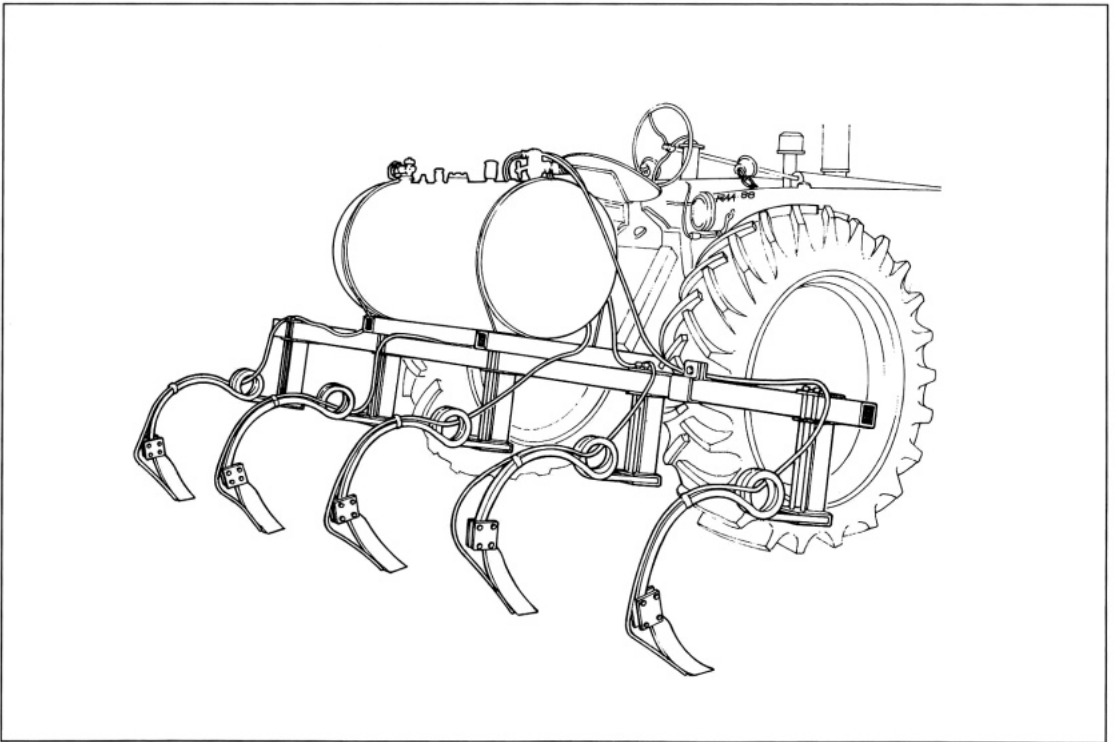

vary like urea, which has a proclivity to absorb moisture. A further advantage is that only the noncorrosive plastic tube of the peristaltic pump contacts the aqua-ammonia.

When applying urea or aqua-ammonia to the root zone of rice plants in a flooded ricefield, it is essential that the fertilizer not be exposed to floodwater. It must be sealed into the soil by a layer of soil between the standing water and the injected fertilizer. If the urea or aqua-ammonia is exposed to the floodwater, much fertilizer is wasted in the water. The injector shown in Figure 6.9 has fins on the bottom of the skids to “seal” the aqua-ammonia into the mud so that it is not diluted by the irrigation water.

6.9. Manual, ground-driven, 4-row aqua-ammonia injector for wetland rice.

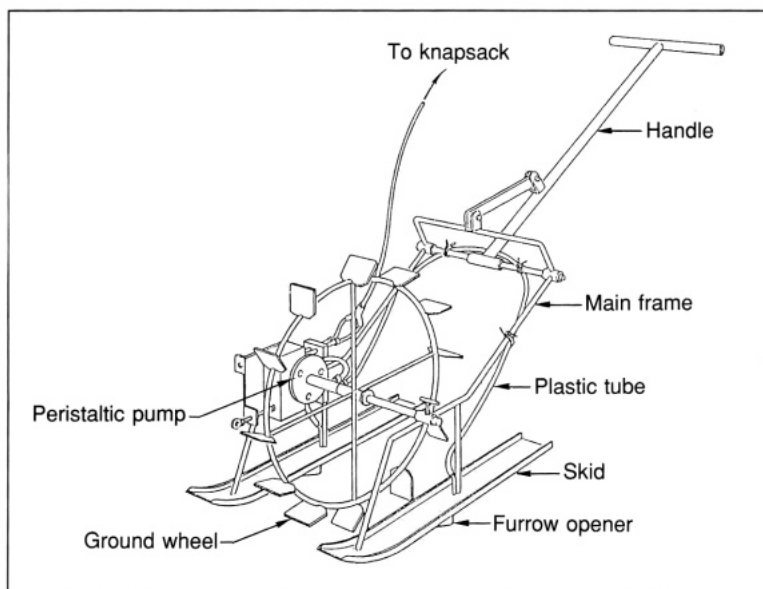

7 Weed control

A weed is an unwanted plant in a farmer's field. One farmer's crop may be another farmer's weeds. Weeds take nutrients, water, and sunlight away from the crop and sometimes make it impossible to grow the crop. This chapter discusses mechanical and chemical means of ridding a field of weeds. Since some of the machines for applying chemical herbicides are the same as those for applying insecticides, some of the tools and machines described in this chapter are also useful for insect control, described in Chapter 8, and vice versa.

Weeding is one of the most important tasks of the small farmer. Manual or mechanical weeding is most common, but herbicides are becoming increasingly available. Hand weeding requires little capital investment but a large amount of labor, whereas chemical herbicides require a capital outlay but little labor. The best weed control program combines mechanical methods, chemicals, and crop rotation.

Weeds can be controlled in orchards and tree plantations by planting legumes as cover crops. In addition to suppressing weeds, legumes provide soil nitrogen and forage for animals. Hay, plastic, and sawdust mulches are used to suppress weeds and retain soil moisture in some row crops and small fruits such as blueberries and strawberries.

Cattle and sheep are useful in controlling weed growth in orchards and plantation of tree crop such as rubber, coconut, and oil palm. Some farmers use geese to remove grass from strawberry fields.

7.1 Mechanical weed control

Mechanical weeding of upland crops removes the weeds from the soil. Left in the sun, the weeds die of desiccation. In wetland rice, most weeds can be killed by pushing them below the water to suffocate. Row-crop cultivation facilitates

hand weeding and is a necessity for animal- or tractor-drawn mechanical weeders.

Some of the same tools used for weeding are used for hilling (throwing soil up around plants such as potato and maize). Hilling potatoes while cultivating prevents them from protruding from the soil and turning green. Hilling maize smothers weeds within rows.

7.1.1 Manual tools. The machete and the hoe are the most common tools for weeding upland crops. Wetland rice planted in rows is easily weeded with the push-type weeder. If the rice is not planted in rows, hand pulling is necessary.

A person can hand weed only 0.1 ha of flooded rice a day. The push-type rotary weeder illustrated in Figure 7.1 not only eliminates the back-hending work of hand weeding, but enables a worker to weed 50% more a day. The worker pushes and pulls the implement back and forth between the rows. A skid in front of the implement provides flotation in soft soil. Weeds are uprooted and pushed underwater.

The cono-weeder, shown in Figure 7.2, uses a conventional weeder frame but has two conical rotors mounted in tandem with opposite orientation. Smooth and serrated

7.1. Push-type rotary weeder for wetland rice.

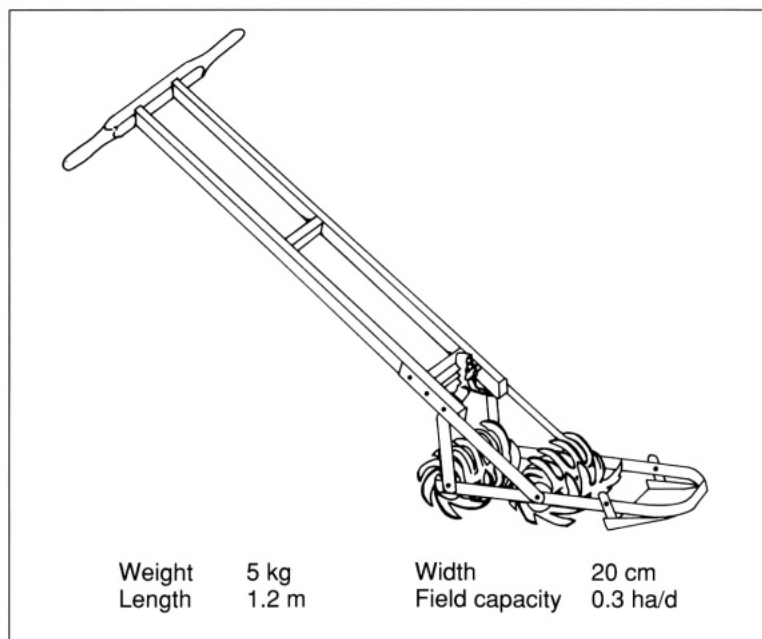

7.2. Cono-weeder.

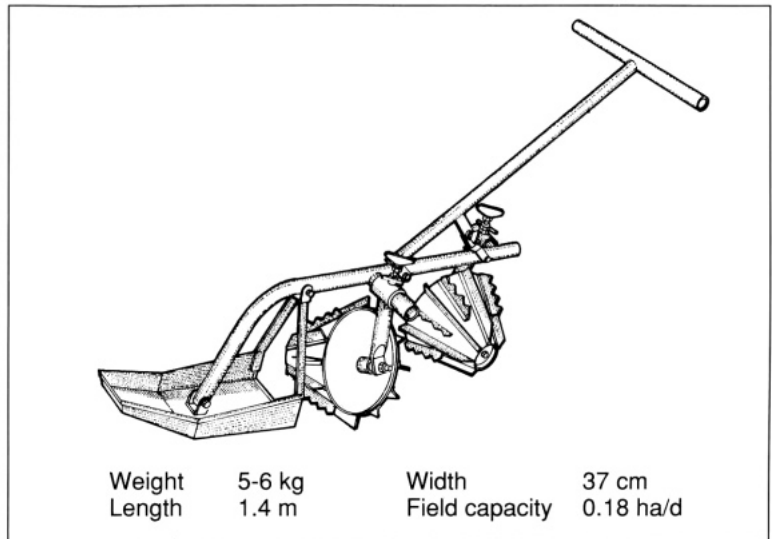

blades mounted alternately on the rotors uproot and bury weeds. Because the rotors create a back-and-forth movement in the top 3 cm of soil, the cono-weeder can satisfactorily weed in a single forward pass without a push-pull movement. The sheet metal rotors are hollow to increase flotation in soft soil. Manual weeders are made in both one- and two-row models, but two-row machines are rarely used.

For upland crops, the long-handled weeding hoe is the universal weeding implement, although the same short-handled hoes used for primary tillage are often used for weeding in primitive areas. Research in Nigeria found that with a long-handled hoe the spinal muscle force was only 20% as great as when using a short-handled hoe, and the lumbosacral joint reaction only 38% as great. Thus a long-handled hoe will reduce the backache of hoeing.¹ Long-handled hoes have two main variations: those that chop both weeds and soil, and those that cut the weeds below the surface by a push-pull action. The former functions in all soils; the latter works best in light, stone-free soils.



7.3. Push-type cultivator.

Manually powered push-type cultivators (large-wheel hoes), such as in Figure 7.3, are most commonly used on vegetable farms in loamy to light soils. The combination of the large 18-in (46 cm) wheel and adjustable handles allows the operator to regulate work depth, while the frame, which usually carries 5 shovels, can be varied from about 10 to

15 in (25 to 40 cm) in width. A large wheel hoe weighs about 11 kg. The large wheel provides evenness of effort, since the wheel rolls over small stones and uneven soil.

7.1.2 Animal- and tractor-powered machines. Weeding does not require as much power as tillage, but it does require control to assure that few weeds survive and that none of the crop is destroyed. The cultivator, drawn by animals or mounted on a tractor, is the most common weeding machine.

A between-the-row cultivating implement travels between two adjacent rows. When drawn by a yoke of animals, one animal is outside the right-hand row and the other is outside the left-hand row. Ards (as shown in Figures 4.7-4.10) set for shallow plowing are commonly used for removing weeds from crops such as maize, bean, and potato. The farmer must make several passes to completely cultivate the area between the rows, but the technique does not require expensive equipment. Moreover, rows that are not quite parallel can be weeded by maneuvering the ard without harming the crop.

The five-tine lever-adjustable cultivator (Fig. 7.4) is a superior implement for weeding using animal draft. These cultivators normally have a hand wheel in front to help control depth. The hand lever facilitates adjustment for row widths of 60-106 cm (24-42 in).

7.4. Animal-drawn, 5-tine between-row cultivator.

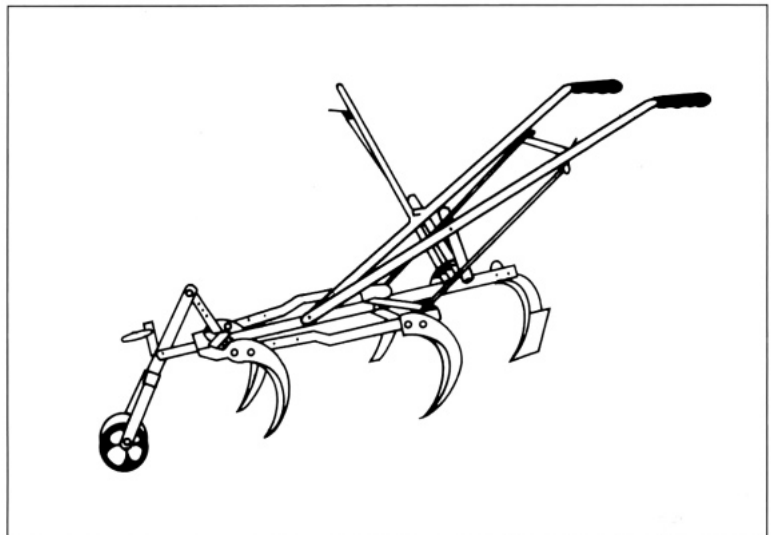

Horse-drawn, over-the-row cultivators (Fig. 7.5) are often designed so the cultivator gangs can be moved right or left relative to the wheels and main frame. This feature is important when the rows are not quite parallel. In some units, the movement of the gangs is accomplished from the operator's seat, which is linked to the gangs. The operator shifts his weight to the right and the cultivator gangs shift to the right. Other models have a stationary seat, and the operator uses foot pedals to move the gangs. Operator-controlled cultivators that mount on the three-point hitch of a farm tractor have a rigid frame and hitch, but the gangs are connected to foot pedals so the operator can adjust for crooked rows. The tractor driver must drive carefully to avoid overworking the cultivator operator.

A tractor cultivator usually has one gang for each side of a row. A one-row cultivator as shown in Figure 2.7 has two gangs; and an 8-row cultivator, 16 gangs. The soil-engaging part of the gang differs depending on soil, crop, economics, and farming practice. Gangs are mounted on tool bars on the front, sides, and rear of the tractor. The front and rear wheels of the tractor and the cultivator gangs must be carefully adjusted to fit the row width of the crop. For best performance and ease of operation, the cultivator should cover the same number of rows as the planter used to plant the crop. For example, a crop planted with a six-row planter should be

7.5. Horse-drawn, over-the-row cultivator with hoe steering.

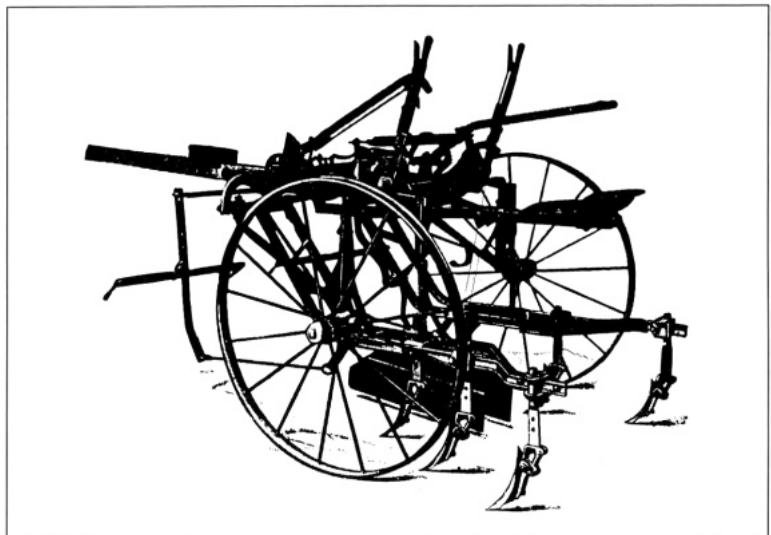

cultivated with a six-row cultivator. There is apt to be some row width variation, but if the cultivator is set up for the same number of rows as the planter and begins where the planter began, the farmer's work is considerably easier.

Shovels and sweeps on tractor cultivators are similar to those used on manual and animal-drawn cultivators. The common cultivator shovel is 5 cm (2 in) wide, but shovels are made up to widths of 9 cm (3 1/2 in). Sweeps are set to run nearly parallel to the soil surface. The outer wing tip of the sweep should be only 5 mm above the sweep point. Sweeps range in size from 14 to 60 cm (6-24 in). Sweep size is the maximum width of the sweep. Half sweeps run next to plant rows. Shovels and sweeps are made of heat-treated high-carbon steel for durability. Figure 7.6 illustrates four elements used with cultivators.

Trail-type rotary hoes consist of front and rear gangs set in a common frame with spiders (hoe wheels) 15 cm (6 in) apart. Each gang is mounted so that the spiders of the rear

7.6. Soil-engaging elements of a typical cultivator.

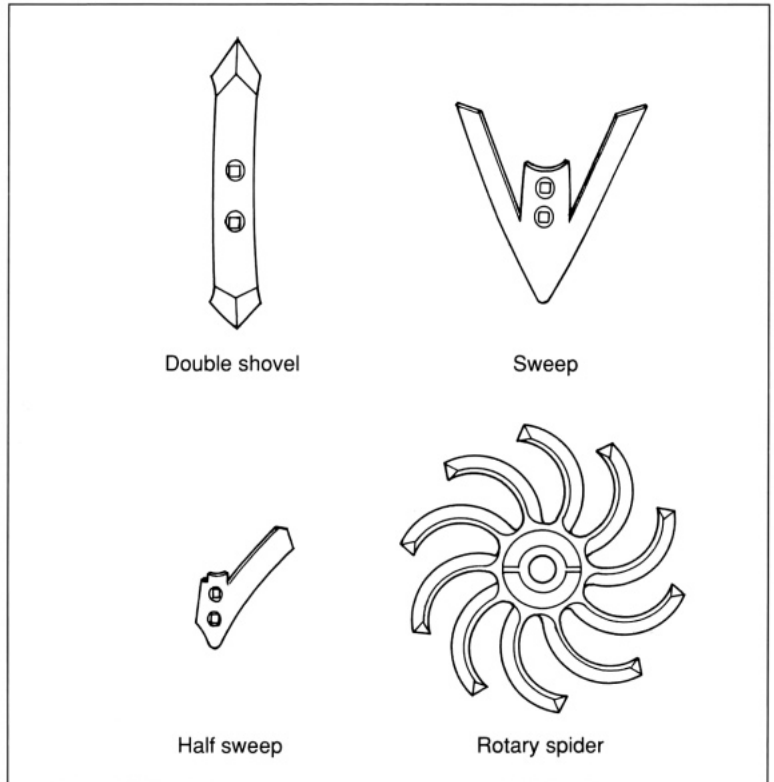

gang extend forward between the spiders of the front gang, and the soil is worked every 7.6 cm (3 in). Trailing-type rotary hoes are made in widths up to 7.3 m (24 ft). In crusty soil restraining the emergence of seedlings, the rotary hoe is set to penetrate 2.5-5 cm (1-2 in) into the soil, and field speed is 10-15 km/h (6-9 mph) over the crop and in the same direction as the rows. The crust is pulverized, and many weed seedlings are removed, but the crop seedlings are usually unharmed. An adage advises, "When operating a rotary hoe, put the tractor in high gear and don't look back!" A rotary hoe can be used to pulverize and pack the soil by pulling it backwards.

Rolling cultivators are similar to rotary hoes except that rolling cultivators have twisted fingers (blades) that can move the soil laterally as well as provide a slicing action. Rolling cultivator gangs are made as right-hand and left-hand gangs with two to six spiders per gang. Right-hand and left-hand gangs are usually mounted as pairs. The gangs can be canted in the horizontal plane to control the degree of cultivation and lateral soil movement, and tilted to till the sloping side of a bed as well as working on the flat. Rolling cultivator gangs are normally mounted on tool bars and are frequently used for hilling crops such as potato as well as for weeding.

Cultivating row crops is not easy. Sitting on a horse-drawn cultivator or driving a tractor demands close attention to guide the vehicle over the plants. Cultivation is monotonous, and there is a tendency to doze until awakened with the shock that the cultivator is off the row and removing the crops as well as the weeds!

For a fallow field of grain stubble in a dryland farming rotation, any growing plant is considered a weed. A rod weeder is used to remove weeds without disturbing stubble mulch. The rod weeder (Fig. 7.7) is usually ground-driven and is made in both horse-drawn and tractor-drawn models. The working element of a rod weeder is a ground-driven steel bar, about 25 x 25 mm (1 x 1 in). The length is equal to the width of the machine. The rod rotates in a direction opposite to the wheels of the machine and is set to operate 5-10 cm (2 to 4 in) below the soil surface. Plants struck by the rod are pulled from the soil as they wrap around the rod. Because the rod rotates in a direction opposite to the direction of travel, uprooted plants are thrown from the rod to desiccate in the sun.

7.7. Rod weeder

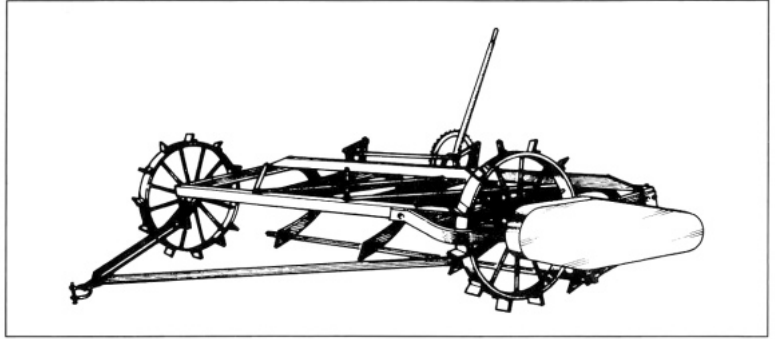

The rod weeder is useful only in dryland fallow. In lush, humid areas, the rod becomes clogged with vegetation. Single units range in working widths from 2.5 to 3.6 m (8-12 ft) but may be ganged together to form widths of 11 m (36 ft).

7.2 Chemical weed control

Pesticides are chemicals used to control pests. Herbicides control weeds, insecticides control insects, and fungicides control fungal diseases. Pesticides are applied as gases, solids, liquids, aerosols, or suspended solids.

Fumigation is the use of gaseous pesticides. It is used to kill soilborne diseases and organisms. A gastight cover is placed on the soil to be treated, and the fumigant is placed under the cover. The gastight cover is usually a polyethylene sheet laid over the soil with the edges buried to seal in the gas. Tractor-drawn machines unroll the polyethylene sheet and place earth over the sheet edges. Common fungicides such as methyl bromide and chloropicrin (tear gas) are available in pressurized cans for injecting the gas under the plastic. (Note that methyl bromide can kill humans as well as soilborne pests!)

Steam is used as a soil fumigant. For example, in fumigating soil for a tobacco seedling nursery, an airtight steel cover 1.5 x 2.25 m and 12 cm deep is placed over the seedbed to be treated, and steam is piped through the cover and into the soil. Fumigation is expensive and is used only for high-value crops and seedbeds.

Fire is a chemical reaction, so flame cultivation is included in this section. Shifting agriculture utilizing a slash-and-burn (swidden) system uses fire to kill weeds, so crops such as maize can germinate and obtain a head start on weeds. Hand-held kerosene flamers resembling large blowtorches are used

in some areas to remove weeds from irrigation canals. In areas where propane gas is inexpensive, flammers have been used to control weed in cotton. In successful flame cultivation, the crop plant must be larger and more heat resistant than the weeds. A typical tractor-mounred flamer consists of a rear tool bar with propane tank and flammers for four rows. Skids positioned along each row control flame height. Burners with tips 20 cm (8 in) wide are positioned on both sides of a row so that flames are directed at 45° to both sides of the row, striking the ground about 5 cm from the plants.

Dusters mounted on tractors or trailed were formerly used for applying pesticides to crops such as potato, and hand-held units, manual or engine-powered, were used on ricefields. A duster consists of a hopper for the dust, an agitator to prevent caking and ensure free flow, a blower to provide air to distribute the dust and to break it into fine particles, and a spout or nozzle to control the direction. However, dusters have been replaced in most field applications by sprayers, since wind easily blows dust about, sometimes damaging other crops; for best results dust should be applied while dew is on the plants. Dusts continue to be used in household vegetable gadens, where the pesticide container serves as a duster as the gardener shakes the container's contents onto the plants. Some pesticides, particularly fungicides for greenhouse use, are sold as dusts. These are applied by hand-carried manual or motor-powered blowers.

A simple means of applying a liquid pesticide is a hand-pushed *roller applicator*. A typical roller applicator consists of a steel cylinder 50 cm in diameter and 40 cm wide. The width depends on the width of the crop row. The unit's other components are a pipe to drip herbicide onto the roller, a plastic tank containing the herbicide, and a handle. When the handle is placed on the ground, the drip pipe is above the tank, thereby preventing liquid from flowing from the tank. The roller applicator is advantageous in that there is no pesticide drift onto adjacent crops; the unit is simple to manufacture (having no pumps or valves) and easy to use. The primary disadvantage is that the applicator does not treat all vegetation in a rough field. Weeds in soil depressions or crevices may not come in contact with the roller,

The *wick sprayer* is another wiping-action applicator. It is used for wiping postemergence, translocated herbicides

such as glyphosate on weeds extending above the crop canopy or between crop rows. Contact with the top one-quarter to one-half of actively growing plants is usually sufficient for optimum control. The wick that transfers the glyphosate solution from the reservoir to the weeds is usually a nylon or polypropylene rope. Wick sprayers are made in both hand-held and tractor-mounted units.

The wick sprayer is often impractical because the weeds are below the crop canopy. In that case, the herbicide must be delivered in droplets, either by field sprayers or by aerial application. Optimum droplet size requires careful assessment. Small droplets provide more coverage per weight of solution. However, the smaller the droplet, the greater is the risk of its being carried by the wind. Drift wastes herbicide and can damage a nearby susceptible crop. Table 7.1 relates droplet size to drift.

Because droplets smaller than 100 μ drift excessively, low-volume sprayers commonly use droplet sizes of 100-250 μ for controlled droplet application (CDA). A typical pressure sprayer with a flat spray tip (#8006) at 40 psi creates droplets with a mean diameter of 500 μ .² In general, a coarse spray consisting of large droplets is best for applying herbicides, and a fine spray of small droplets is best for fungicides and insecticides.

Foggers, which produce droplets smaller than 50 μ , normally in the range of 5-15 μ , are discussed under chemical pest control in Chapter 8.

Most agricultural sprayers create spray droplets by forcing a liquid spray solution through a nozzle. The nozzle meters the solution, atomizes the liquid into droplets, and disperses the droplets onto the crop. Nozzles are crucial to the

Table 7.1. Effect of droplet size on drift when falling 3 m in a 5 km/h wind.³

Droplet size ^a (μ)	Drift
3	8 mi (13 km)
10	1 mi (1.6 km)
15	2000 ft (610 m)
100	50 ft (15m)
500	5 ft (1.5 m)

^a 1 micron (μ) = 0.000001 m = 1/25,000 in.

operation of a sprayer. Nozzles are normally made from brass, nylon, or specially formulated plastic. Stainless steel, tungsten, and ceramic nozzle tips, however, wear better and are preferred by commercial operators despite the higher initial cost.

The hollow-cone nozzle produces a conical pattern, with the droplets concentrated at the outer edge of the cone. It is often recommended for good leaf coverage of field crops and is also used to apply insecticides. The flat-fan nozzle makes an elliptical pattern and is used for applying fertilizers as well as herbicides and insecticides. The nozzles are set on the spray boom so that the tips of adjacent spray patterns overlap to provide uniform coverage. The flood or wide-angle nozzle provides a wider area of coverage for a specific height, but the pattern may not be as uniform as that from a nozzle with a smaller spray angle. Common hollow-cone and flat-fan spray angles are 65° and 80° . The usual angle for flood nozzles is 120° . Figure 7.8 illustrates various nozzle spray patterns.

The nozzle on most manually operated, compressed-air sprayers or knapsack sprayers is adjustable. By turning a ferrule on the nozzle, the operator can change from a fine spray to a coarse spray to a nearly solid stream.

A nozzle on a tractor-powered or self-propelled field sprayer usually consists of a plastic body that attaches to the spray boom. A filter prevents the nozzle from clogging, a spray tip provides the orifice required for the work, and a pressure diaphragm prevents the spray solution in the boom from dripping when the operator stops spraying.

Manually operated, compressed-air sprayers are portable and useful for occasional pesticide applications. The units normally hold from 5.5 to 9.5 liters of liquid pesticide (concentrated liquid pesticide in a large volume of water). A stirrup or pump-type handle pressures the sprayer. The

7.8. Nozzle spray patterns.

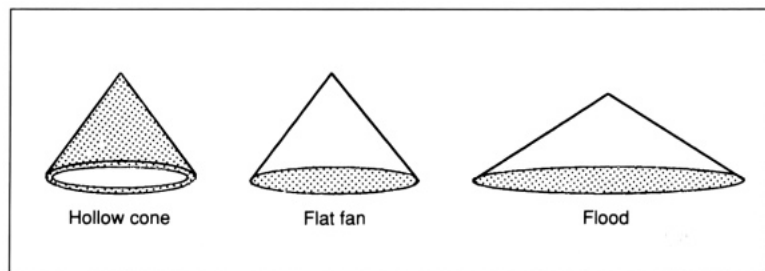

compressed-air sprayer cannot be filled completely with liquid, because an air space at the top of the tank is necessary. Otherwise, there would be no air to compress, and the energy to force the liquid through the nozzle would be absent.

The knapsack or backpack sprayer—worn on the back like a knapsack—is a nonpressurized sprayer with a piston pump operated by nearly continuous hand pumping (Fig. 7.9). The pumping action forces the liquid spray solution into a small surge chamber, which provides a continuous spray as long as pumping continues.

The pump handle extends forward from the sprayer tank so that the operator pumps the sprayer with one hand and holds the spray wand with the other. The largest part of the knapsack sprayer is the reservoir, which is made of brass, stainless steel, plastic, or galvanized steel. Plastic units are popular because they resist corrosion, are lightweight, and are usually inexpensive. Also, the operator can see the liquid level in a translucent plastic reservoir.

The backpack power sprayer is engine-powered. A typical backpack power sprayer has a 20-liter (5.2-US gal) tank, is powered by a 2-stroke air-cooled gasoline engine, and weighs approximately 8 kg (18 lb) when empty.

7.9. Farmer using knapsack sprayer.



In many countries, clean water is difficult to obtain. Large volumes of water must therefore be carried to the field for use with backpack sprayers. For example, to control brown planthoppers in a ricefield, 190 liters of perthane/ha applied at booting is enough. However, farmers are advised to apply 300-500 liters/ha of a water and perthane solution. When plants are small, the rate of 300 liters/ha is adequate, but when the rice canopy is closed, the rate of 500 liters/ha must be used. A farmer using a 20-liter sprayer must apply 20 sprayerloads to 1 ha to obtain a rate of 400 liters/ha.

CDA sprayers are lightweight and produce uniform droplets. By comparison, all the other sprayers mentioned produce a range of droplet sizes, from larger to smaller than desired.

A CDA sprayer forms droplets by running a small stream of liquid spray solution onto a spinning toothed disc (Fig. 7.10). Droplets are formed as they are flung from the teeth of the disc. Droplet size is controlled by the viscosity of the spray solution, the rate of flow of the solution onto the rotating disc, the six of disc teeth, and the speed of the disc. The spinning discs of most hand-held CDA sprayers are driven by electric

7.10. A hand-held controlled droplet application (CDA) sprayer.

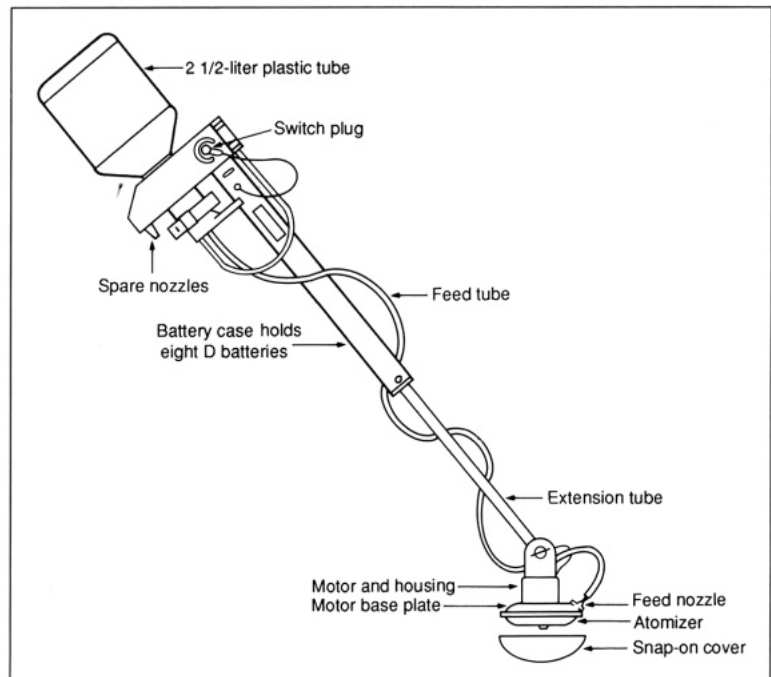

motors powered by ordinary flashlight batteries in the handle. Flow of the spray solution from the reservoir to the disc is by gravity. The application rate can be controlled by adjusting the orifice between the reservoir and the spinning disc, by walking speed, and by boom height. Application rate can also be controlled by adjusting the concentration of the spray solution, but the advantage of the CDA sprayer is that it is a hand-carried unit in which a concentrated spray can be used. This is an important consideration in countries where clean water is not readily available. For example, a CDA sprayer can do a good job of weed control at a rate of 40 liters/ha, whereas a conventional knapsack sprayer requires 200 liters/ha. A disadvantage of the ultralow-volume sprayer is that it produces small droplets that drift easily.

Whether animal-powered, ground-driven or tractor-powered by the PTO (Fig. 7.11), a field sprayer must have a tank, pump, pressure-relief valve, control valve, boom, and nozzles. It should also have a pressure gauge, tank agitator, and filter. Auxiliary devices such as hydraulically operated spray booms, sonar control of boom height above the ground, foam swath markers, radar computation of ground speed, and computer-controlled spray rate are available. Besides these auxiliary devices, there are many modifications for propelling the spray into the foliage. Field sprayers with low-rate nozzles and CDA applicators utilize fan to blast the small spray droplets into the foliage, thereby reducing drift. Figure 7.12 illustrates the elements of a typical field sprayer.

7.11. Tractor-powered field sprayer.

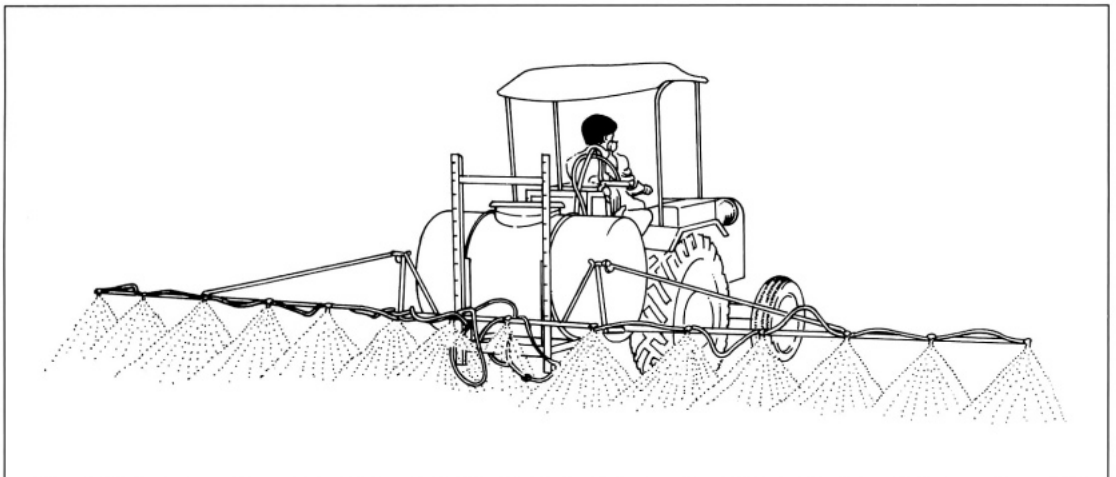

7.12. Elements of a typical field sprayer.

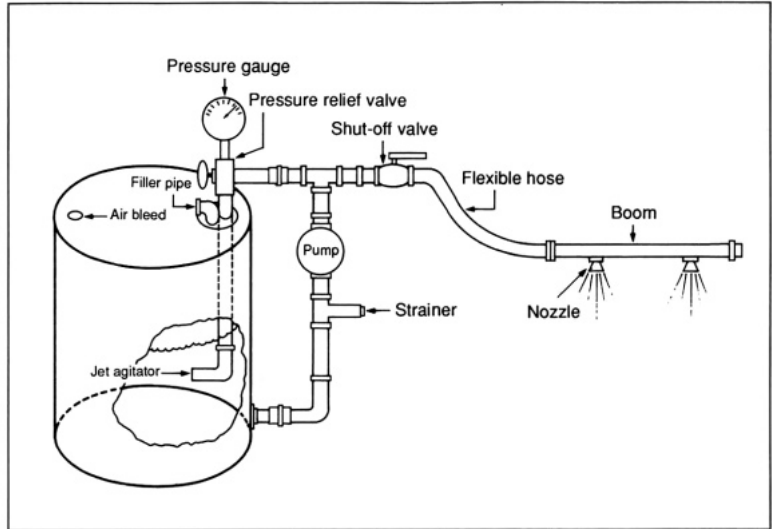

Tillage implements such as a chain harrow, disc harrow, or power harrow are as essential as the field sprayer when applying some pre-incorporation herbicides to the seedbed before planting. Some types of pre-incorporation herbicides must be stirred into the top 5-10 cm (2-4 in) of the seedbed immediately after spraying. For applying these herbicides, a tractor pulling a harrow or a disc follows the tractor and sprayer. It is often necessary to go over the field twice with the harrow or disc, the second pass being perpendicular to the first, to ensure incorporation of the herbicide. Some farmers use one tractor by mounting the sprayer on the tractor and pulling the harrow or disc. The sprayer is shut down for the second pass.

Electrostatic sprayers are designed to charge the spray droplets so there is a powerful attraction between the plant and the charged droplets. A typical voltage is 25,000 V, but the current is only about 3 μ A. An electrostatic sprayer allows the use of small droplets of 50 μ or less, and the high velocity of the droplets and their electrical charge, which makes them mutually repellent, eliminate drift in most situations. Nearly all the spray reaches the plant, with both leaves and stems receiving about even coverage. Practically no spray escapes into the environment. An oil-based liquid formulation is necessary, but the pesticide is supplied ready to use, so measuring and mixing are unnecessary. However, electro-

static sprayers have not yet been accepted by most farmers because of their high cost and operational problems.

A ground-driven field sprayer manufactured in Paraguay uses a diaphragm pump powered by a cam fixed to one wheel of the sprayer. Roller vane pumps or centrifugal pumps are the common pumps for PTO-powered field sprayers. Centrifugal and diaphragm pump are commonly used for applying wettable powder mixtures because they withstand the wear of the abrasive particles in those mixtures better than roller or gear pumps.

Disposal of unused spray solution after spraying is a common problem. Many farmers spray the remaining solution on the crop—in effect applying more spray than is required or lawful. Others dump the remainder. A proper disposal site has a washdown area for the sprayer as well as holding and evaporation basins for the unused spray solution. None of these means of disposing of unused spray solution is satisfactory.

Some sprayers hold only water in the reservoir, and the pesticide is injected into the water as it enters the boom. Thus, after spraying, no spray solution remains to be disposed of. As environmental concerns receive more attention and as microprocessors become increasingly available for agricultural machinery, this type of sprayer will gain acceptance.

REFERENCES CITED

1. Nwuba E I U, Kaul R N (1986) The effect of working posture on the Nigerian hoe farmer. *J. Agric. Eng. Res.* 33:179-185.
2. Spraying Systems Company (1984) TeeJet Catalog 38. Wheaton, Illinois.
3. Kempen H (1978) Controlled droplet application—new tool for your growers. Agri-Fieldman and Consultant. Meister Publishing Co., Ohio.

BIBLIOGRAPHY

- Boise L M, Dombrowski N (1976) The atomization characteristics of a spinning disc ultra-low volume applicator. *J. Agric. Eng. Res.* 21:87-99.
- Diprose M F, Benson FA (1984) Electrical methods of killing plants. *J. Agric. Eng. Res.* 30:197-209.
- Fraser F, Burrill L (1979) Knapsack sprayers. International Plant Protection Center, Corvallis, Oregon.
- Millier W F (1987) How to apply pesticides accurately. Agricultural Engineering Facts EF-11, Cornell University, Ithaca, New York.

8 Insect and predator control

This chapter primarily concerns insect control, but also covers tools and techniques for controlling other pests such as rodents and birds.

One method of insect control that does not involve tools or chemicals is to observe the correct planting time. For example, the Hessian fly can be controlled in winter wheat if the wheat is not planted until after a certain date.

Crop rotation is another important means of controlling insects. Specific insects thrive on specific crops. If the same crop is grown year after year, an increasing number of insects adapt to feeding on it. Crop rotation can break the host-plant-insect relationship and reduce the insect population. Similarly, pests that have few alternative hosts can be controlled by removing the crop by a specific date. For example, pink bollworms in cotton can be controlled if the stalks are uprooted and burned when there are no alternative host plants.

The use of beneficial insects or diseases to control harmful insects is called biological control. For example, wasps are used to control alfalfa weevils, and disease is introduced to control Japanese beetles. When both biological control and pesticides are used, pesticide application must be timed so the beneficial insects will be unharmed. Another form of biological control is growing plants that discourage pests. For example, lemongrass is often grown in gardens to repel certain insects, and marigolds are planted in fields to discourage nematodes.

8.1 Mechanical control

Static methods of insect control such as fine mesh screens are commonly used in plant breeding establishments but are too expensive for field production. Electric fences are installed by

rice breeding institutes to kill rodents. Plastic netting protects fruits such as blueberries from bird damage. The netting is lightweight and is draped over the bushes when the berries begin to ripen. After the berries are ripe, the netting is removed, the berries are harvested, and the netting is rolled up. In Southeast Asia, certain valuable varieties of tree fruits are protected from bats by placing a rattan cage around each fruit.

The simplest mechanical method of removing insects from crops is to pick them off manually. Where insecticides are not available, children are often fielded to pick off harmful insects. During World War II, German school children picked Colorado potato beetles to save the potato crop. Similarly, home gardeners often pick Japanese beetles from crops.

In China, worm combs, worm scoops, and worm catchers are used to remove worms and stem borers from rice plants.¹ Worm combs (Fig. 8.1) and worm catchers are used to comb worms from the leaves of rice plants and drop them into the water to drown. This work requires about 3 h/ha. A worm scoop is a shallow bamboo basket on the end of a long handle. The worms are caught as the scoop is swept across the leaves.

8.1. Worm comb.

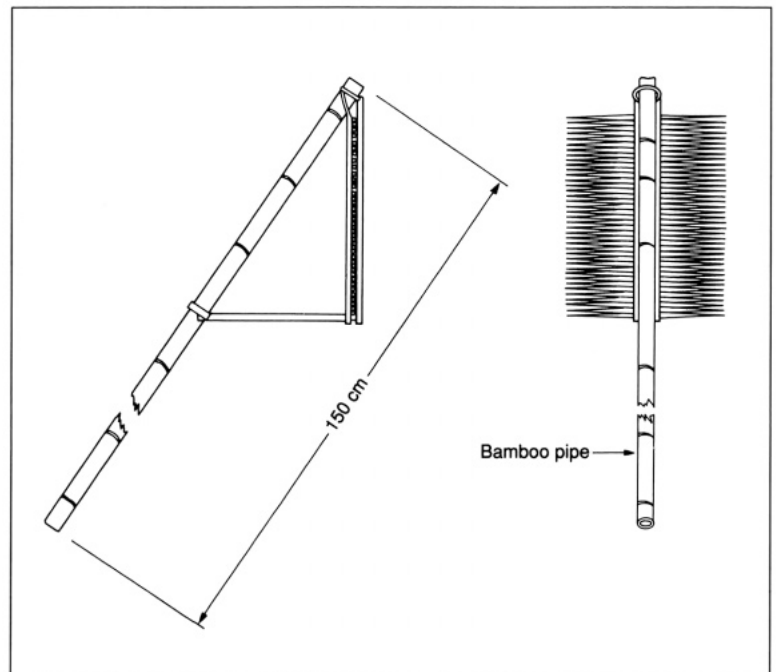

Best results are obtained if the scoop is used after rain when the worms are sluggish.

Tillage practices can also be used to reduce the insect population. Research in China indicates that early spring plowing can exterminate hibernating rice borer (*Schoenobius incertellus*) and rice stem borers (*Chilo simplex*).² In North America, the maize borer can be controlled by clean fall plowing in which all maize stalks are buried.

When birds are a problem — especially near harvest time—they can be frightened away by noise and slingshots. Elaborate networks of string and cans radiating from a hut are often used to frighten away birds. Automatic noise makers powered by propane or acetylene gas to produce loud explosions are initially successful but, because of the regularity of explosions, soon lose their effectiveness. Kites and scarecrows resembling owls are also effective until the birds realize no threat exists.

8.2 Chemical control

Most of the spraying equipment for weed control described in Chapter 7 can also be used to apply insecticides. Foggers or mist blowers using oil-based sprays are used to control mosquitoes, fungi, and other pests.

The fogger shown in Figure 8.2 uses a Helmholtz resonator to produce a pulse jet by the same principle as the V-I buzz bomb or a pulse jet furnace. Gasoline is burned in a resonator, creating about 80 pulsations per second in the resonator pipe.

8.2. Portable fogger.

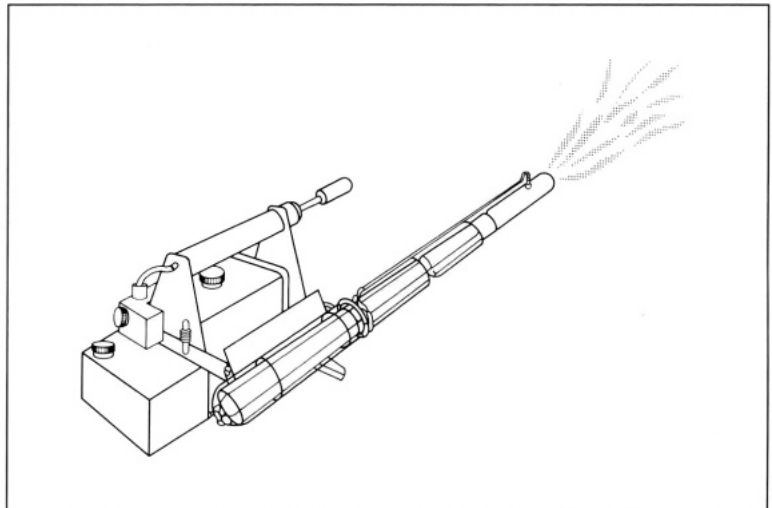

An oil-based liquid insecticide is introduced into the end of the pipe, where it is converted to fine droplets and forced into the air by the exhaust jet. A typical hand-carried model weighs 9 kg and distributes 10-30 liters of pesticide per hour.

Small, hand-held, electrically operated foggers are commonly used in greenhouses. They are similar to household humidifiers and produce very small (5-15 μ) droplets by vibration. A fan blows the droplets onto the plants.

Pesticides for soil-dwelling nematodes, and systemic pesticides that are absorbed by the roots and translocated to the stem and leaves to control sucking or biting insects are usually applied in dry granular form during planting. The application equipment for granular pesticides is similar to that used for applying dry fertilizer.

Liquid systemic pesticide can be injected at the root zone of rice plants in lowland cultivation with a peristaltic pump injector similar to the one illustrated in Figure 6.9. Nitrogen fertilizer can be injected between adjacent rows, and the roots will eventually reach the fertilizer, but since the effect of a pesticide is desired immediately, systemic pesticide must be placed directly into the root mass of each plant.

Pheromone traps contain a chemical sex attractant to capture specific insects. The traps are usually made of inexpensive paper, plastic, or metal, and set above the canopy of the crop to be protected. When using pheromone traps, it is important that a sufficient number be placed in the field and that they also be placed in adjacent fields planted with either the same crop or with other host plants.

REFERENCES CITED

1. Ma C Fengchow, Takasaka T, Yang Ching-wen (1958) A preliminary study of farm implements used in Taiwan Province. Plant Industry Series No. 4. 2d ed. Joint Commission on Rural Reconstruction Taipei, Taiwan, China. p. 158-163.
2. Huang C P, Lo S N, Shao H C (1957) Experiment in early spring plowing in order to exterminate hibernating insects in rice fields [in Chinese]. East China Sci. Agric. J. 1:42-44.

BIBLIOGRAPHY

Gunkel W W, Campbell O F. (1984) A granular pesticide applicator for blackbird control in growing corn Staff Report No. 84-2. Department of Agricultural Engineering, Cornell University, Ithaca, New York. 12 p.

187 DIBBLE STICKS, DONKEYS, AND DIESELS

Hughes H A (1982) Crop chemicals. Fundamentals of machine operation series. 2d ed. Deere & Co., Moline, Illinois. 269 p.

Huitink G (1980) Pattern your AG spray plane. Publication MP 183. Arkansas Cooperative Extension Service, University of Arkansas, Little Rock, Arkansas. 12 p.

Thompson L Jr., Skroch W A, Beasley E O (1981) Pesticide incorporation, distribution of dye by tillage implements. Publication AG-250. North Carolina Agricultural Extension Service, North Carolina State University, Raleigh, North Carolina. 32 p.

9 Harvesting

Harvesting is usually the high point of the agricultural calendar, for it is the time when the fruits of the farmer's labor are about to be realized. Timeliness is essential; thus, a peak work demand occurs at harvest time. Tools and machines are used by most of the world's farmers to alleviate the demands of much work in a limited time. The tools and machines used in harvesting grain, root, forage, and fiber crops are discussed in this chapter.

9.1 Grain harvesting

Because the method by which grain is harvested affects subsequent operations such as threshing, storage, and milling, it must be selected with care. Among the conditions to consider are evenness of ripening, type of field, weeds, animal pests, labor, and economics.

The three phases of grain harvesting are reaping, threshing, and cleaning. The intervals between these operations vary greatly depending on the harvesting method employed. It is often necessary, for example, to dry the grain, after reaping to avoid spoilage in storage. Wheat, barley, rye, and maize can be consumed by humans after threshing. Rice, oats, and some sorghums must be hulled before they can be consumed by humans, although they are usually stored with hulls intact.

Grain must ripen before it can be harvested. Many grains such as wheat, oats, rye, barley, and maize are usually harvested at a dry time of year. Rice, on the other hand, is often harvested in fields where water-saturated soil cannot support the machinery used to harvest grain on dry land.

Harvest time is the most important time of the agricultural calendar. Until the grain is harvested and safely stored, the farmer's investment in tillage, seed, fertilizer, and pest control cannot be compensated. Furthermore, grain to feed the family cannot be obtained.

9.1.1 *Hand tools*. The ani-ani is a specialized grain harvesting tool used in Indonesia and southern Philippines to harvest certain rice varieties (Fig. 9.1). It consists of a wooden peg set through a thin, crescent-shaped piece of light wood carved to fit the palm of the harvester. A thin steel blade, about 3 cm long, is set into the wood. The farmer cuts one stalk of rice at a time by using the index and second fingers to pull the rice stalk across the blade to sever a short piece of stem and the attached panicles from the plant. The severed stem is about 12 cm long and is held in the fingers until a bunch is collected. The bunch—a miniature sheaf—is tied with a straw and later sun-dried and threshed. The ani-ani came about because native varieties of rice did not ripen uniformly and had to be harvested as individual stems. Sickles are replacing the ani-ani as even-ripening, higher yielding varieties are increasingly planted.

The sickle is the basic tool for manual harvesting of grains and other cereals. Hand sickles have evolved into two general types: serrated (Fig. 9.2) and smooth (Fig. 9.3). The serrated edge is needed to cut tough and abrasive rice stalks. A typical rice sickle is 25-30 cm long and has a curved steel blade and a wooden handle. The farmer holds the rice stalks in the left hand and cuts across the base of the stalks with the sickle in the right hand (or vice versa if he is left-handed). One person

9.1. Ani-ani for harvesting rice.

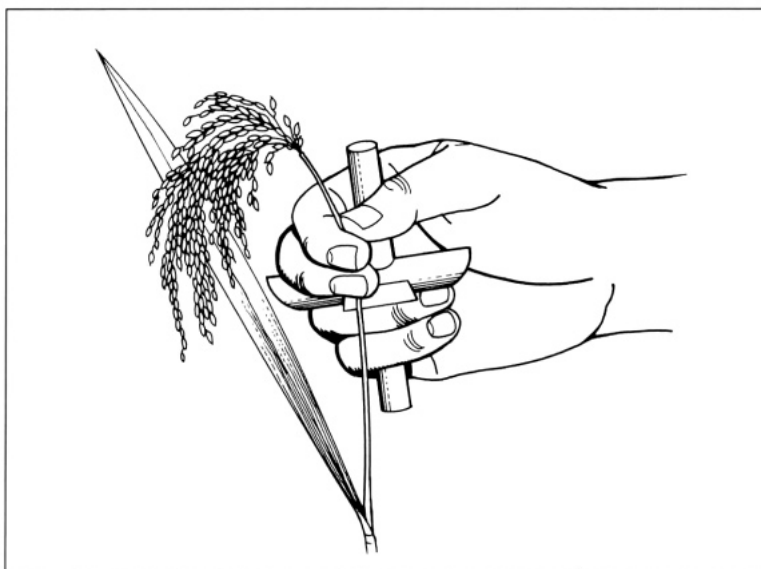

9.2. Serrated sickle.

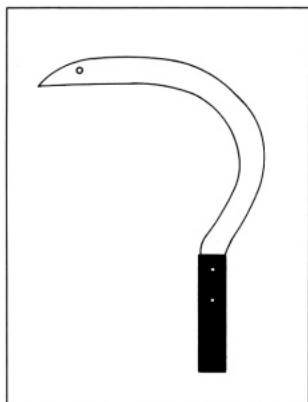
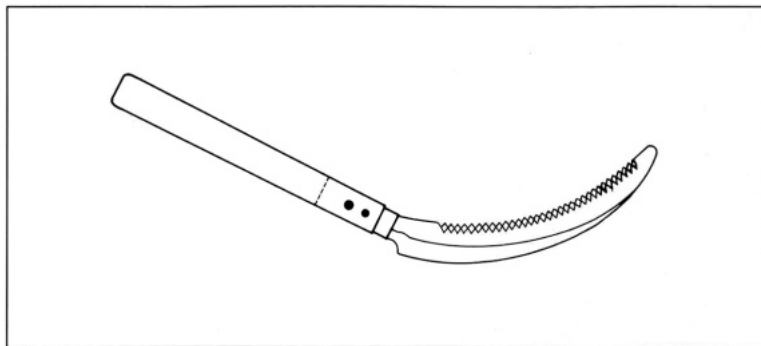

9.3. Smooth sickle.

can harvest about 0.2 ha of rice per day. Sickles and knives for harvesting rice and other grains vary from place to place. The shape of a sickle often depends on tradition as much as utility.

The smooth sickle can be sharpened by hammering the edge on an anvil or honing it with a whetstone. The serrated sickle is more time-consuming to sharpen, since the work must be done with a small file.

The scythe is primarily a tool for mowing grass. When fitted with a cradle to hold and bunch grain harvested by a sweep of the scythe, it is an efficient tool for harvesting grain such as wheat, rye, baryley, and oats. The positions of the nibs (hand holds) on the snath (handle) are adjustable and are fitted to accommodate the farmer's height and arm length. When using a scythe, the farmer takes a short step forward, stops, pivots at the waist, and cuts the crop within the arc described by the blade during the pivoting swing (Fig. 9.4). If the scythe has a cradle, the farmer tips it at the end of the swing, and leaves the grain stalks on the ground to be tied into a sheaf later. Because of the design of the scythe and cradle, grain is cut with a stubble height of about 10-15 cm (4-6 in). Since the scythe cuts grain close to the ground while the sickle can be used to cut grain with a short stem, the type of threshing must be considered when selecting a sickle or a scythe. If the grain is threshed by trampling on a threshing floor, a short stem is desirable. Rice is threshed in some Southeast Asian areas as by four or five people doing a slow, dancelike shuffle in bare feet on top of dried bunches of rice on a woven mat.

Flailing has long been used to thresh dry beans and cereals such as wheat, rye, barley, rice, and oats. A stick can

9.4. Reaping with a scythe.



be used as a flail to thresh these cereals. The crop is placed on a mat or a threshing floor. The threshers sit by the mat and strike the crop with sticks until the grain is separated. Simple sticks are inefficient, however, since the part that strikes the grain should be parallel to the floor. A hand-held stick usually strikes the crop at an angle.

A better tool is the flail, which consists of a working part called a swingle and a handle called a staff. The swingle is a flat piece of wood about 5 cm wide and 75 cm long. It is fixed to the staff by a flexible wooden joint or a leather thong. The staff is about 1.3 m long, depending on the physique of the user. The advantage of a flail over a stick is that, because of the flexible joint, the swingle strikes across the crop with full force. Also, the farmer can work from a comfortable standing position (Fig. 9.5). In colonial America, 7 bushels (190 kg) of wheat or 18 bushels (260 kg) of oats could be threshed with a flail in a day.

Ear maize (cob maize) can be shelled (threshed) by placing the ears in a large gunny sack and beating the sack with a stout pole. The kernels are threshed from the cobs and are not lost, since the entire process takes place in the sack. The disadvantage of the technique is that some of the cobs are

9.5. Threshing with a flail.

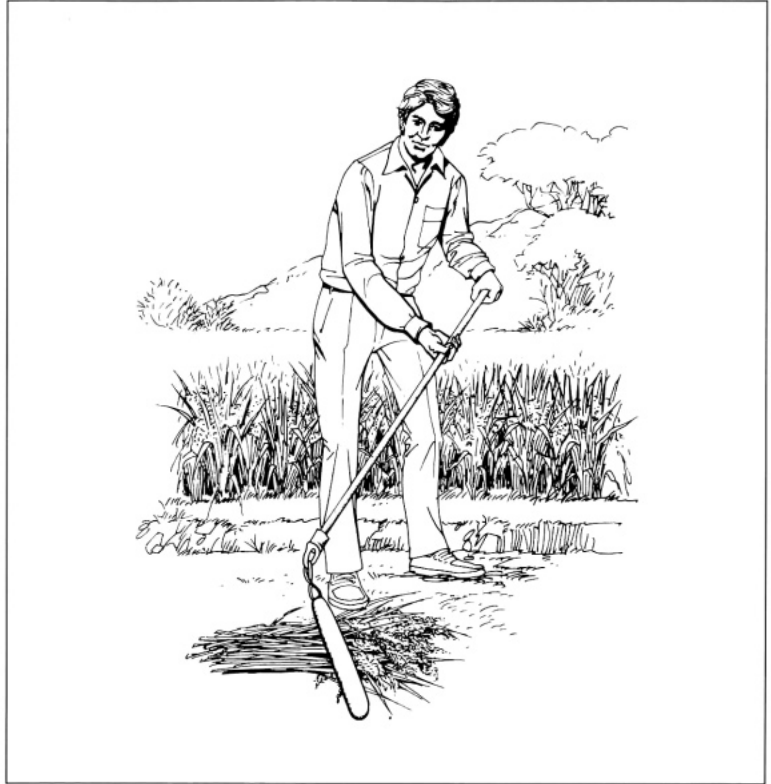

broken and must be removed from the grain. Another method of shelling maize is to build an elevated slatted floor. The spaces between the slats should be larger than a maize kernel but smaller than a cob. The maize is spread on the floor and beaten with a stout stick. The kernels fall through the spaces between the slats and are collected below the platform. These methods provide best results when the maize is very dry.

A simple hand-held sheller consisting of a truncated cone with internal flutes can be used to shell one ear of maize at a time. The sheller is held with one hand, and the ear is twisted in the sheller with the other. These shellers are inappropriate for small farmers because of the considerable time required to shell the maize. Moreover, in many countries no premium is paid for shelled maize free of broken cobs. Hand shellers are more appropriate for plant breeders and other experimenters who need small batches of clean seed maize. A practical type of manually powered maize sheller is the two-hole disc-type sheller (Fig. 9.6). This tool consists of a cast-

9.6. Manually powered disc-type maize sheller.

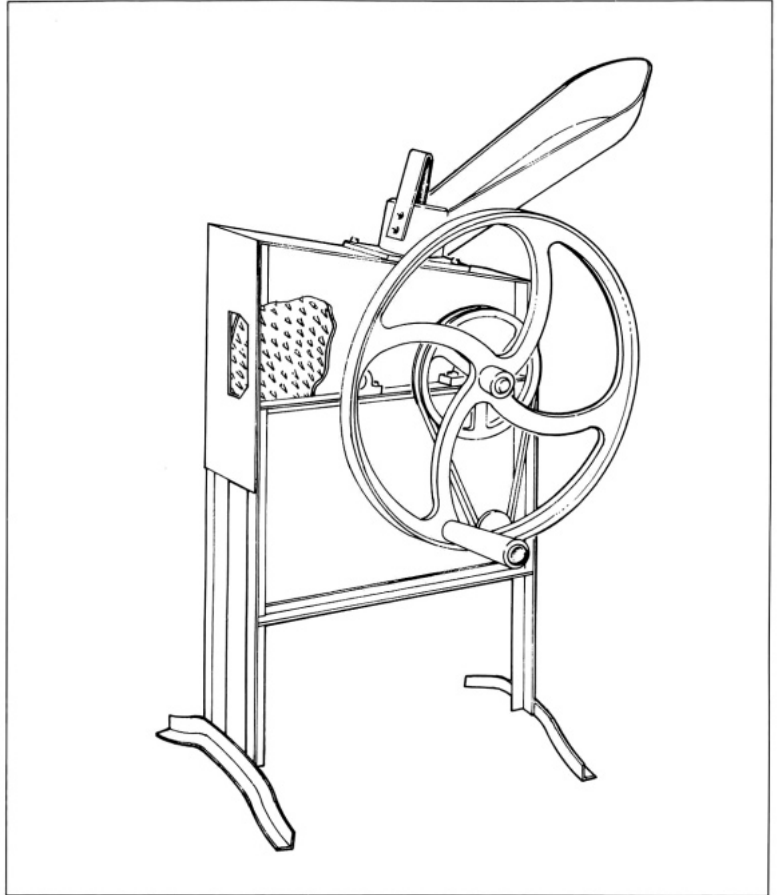

iron disc with teeth on both sides. Chutes feed ears to both sides of the disc. As the ears are constrained between the sides of the machine and the rotating disc, the teeth rotate the ear and remove the kernels. This type of sheller, which may be motor-driven, does not break the cobs.

In Asia, the primary method of threshing rice is beating sheaves against threshing racks, logs, or rocks 3-10 times depending on the variety. The grain falls, and the sheave of straw is tossed aside. Since some rice flies off to the side, many farmers recover the grain by placing the threshing rack in a tub surrounded by sacking for about 300° and about a meter high (Fig. 9.7).

Foot-powered treadle head-threshers with a wire loop cylinder are used by farmers for comfort or for hard-to-thresh rice varieties (Fig. 9.8). The operator holds the grain (head)

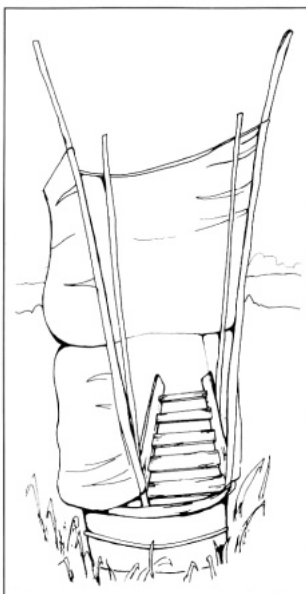

9.7. Rack in tub for threshing rice.

end of the sheave in the thresher. When the wire loops have stripped out the grain, the sheave of straw is tossed aside. Wire loop threshers are effective for rice, but not for other grains (except perhaps oats). Results of tests of the threshing rack, the pedal thresher, and engine-driven threshers in the Philippines are shown in Table 9.1.

In Bangladesh and Peru, efforts have been made to design hand-cranked or foot-powdered rasp bar threshers, but they have been unsuccessful. Wheat is more difficult to thresh than rice, and the power requirements for a hand-cranked wheat thresher have been too high for farmer acceptance.

Where grain is manually threshed, it is usually cleaned by manual winnowing. The grain is poured in thin stream into

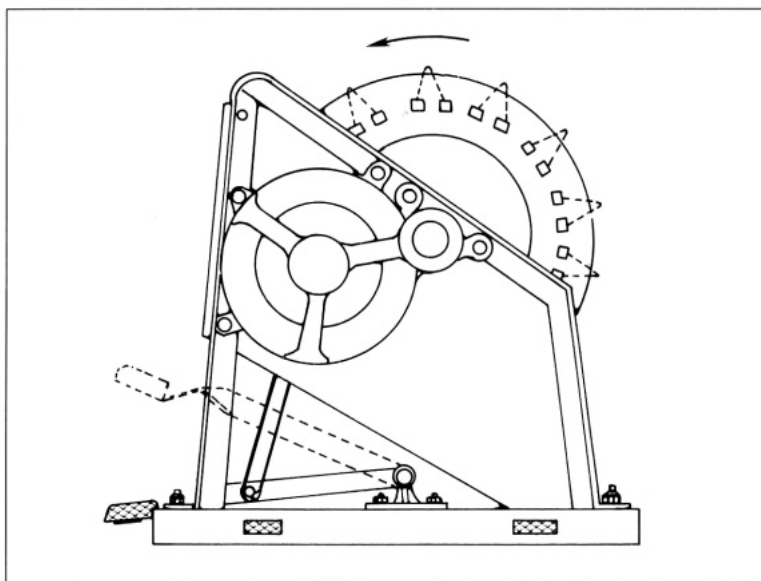

9.8. Wire loop treadle thresher.

Table 9.1. Characteristics of threshing techniques in the Philippines.¹

Method	Laborers required (no.)	Grain output (kg/h)	Grain output (kg/man per h)
Threshing rack	1	44-48	44-48
Pedal wire-loop thresher	2	70	35
Motorized wire-loop thresher	2	200	100
Axial-flow thresher (about 7 hp)	3	880	290
McCormick thresher (about 40 hp)	12	3520	290

the wind so that the wind removes the light chaff and straw pieces as the heavier grain falls into another basket or onto a mat. Sometimes a hand-operated fanning mill is used to create artificial wind.

9.1.2 Reapers. The reaper is a machine that cuts grain and places it in a windrow, where it is gathered and bound into sheaves and carried to a thresher. Large reapers—sometimes called grain windrowers—place the grain in a windrow where it is collected by a combine with a windrow pickup.

The widths of cut for reapers for pedestrian tractors are commonly 1, 1.2, and 1.6 m. These reapers are used primarily for harvesting rice, although they perform well with other small grains. Grain stalks are cut with a scissor action between a reciprocating sickle bar and ledger plates mounted on

9.9. Reaper on pedestrian tractor.²

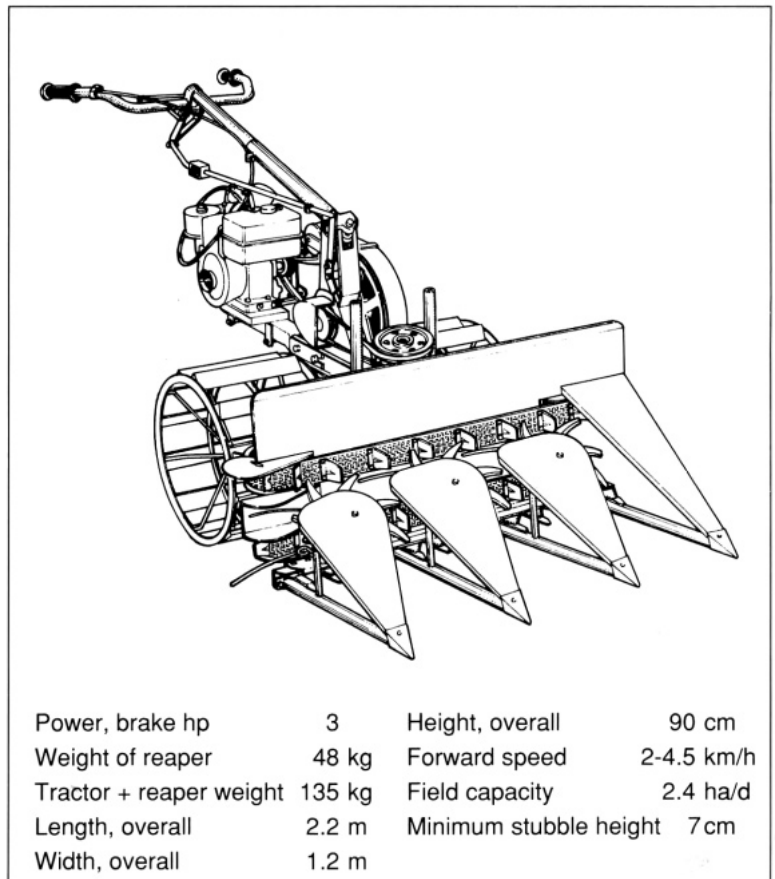

conventional mover guards. Star wheels and two belts keep the crop standing upright as it is moved to the right and released to form a windrow. The reaper shown in Figure 9.9 is an attachment for a pedestrian tractor.

Animal-drawn reapers (Fig. 9.10) were developed from the McCormick reaper, which was basically a mower with a platform. A man walking behind the machine raked the grain from the platform to form a windrow. Today, animal-drawn reapers often have ground-driven cam-rakes. The most common type of animal-powered reaper has a moving canvas platform behind the cutterbar that drops the grain from the right side of the machine into a windrow. This reaper usually has a grain reel that facilitates cutting a lodged crop. When a tying mechanism is added, this type of reaper also becomes a binder (Fig. 9.11).

Animal-drawn reapers and binders are powered by a large bull wheel, which carries most of the weight. By means of gears, chains, and sprockets, the bull wheel powers the sicklebar and the knotter. The knotter uses binder twine to tie stems of grain together into sheaves. The operator dumps five to six sheaves by actuating a foot trip that releases the bundle carrier.

In North America, workers walking behind the binder pick up two sheaves at a time. Standing the sheaves, upright

9.10. Reaper.

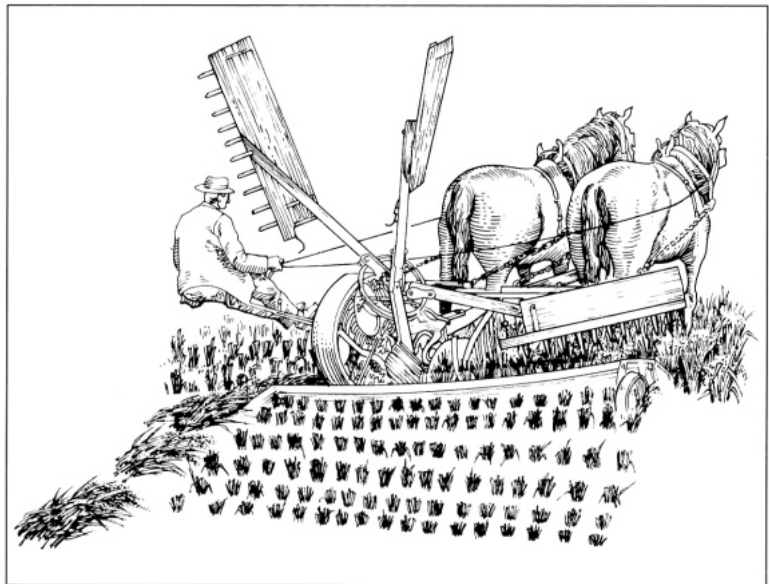

9.11. Grain binder.

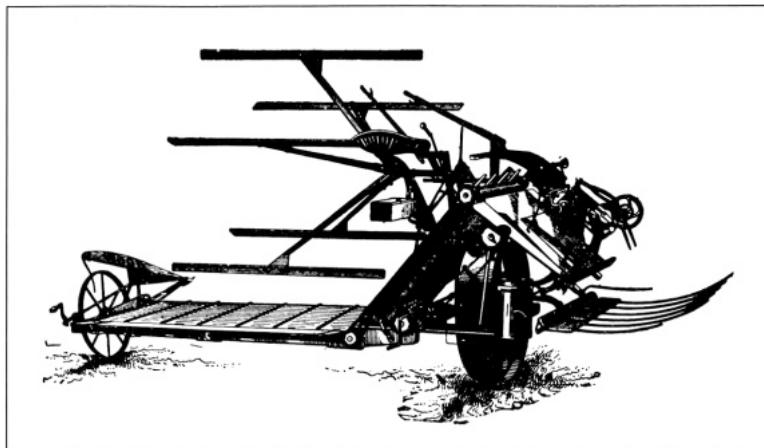

with the grain on the top, they place four together and fan out a fifth sheaf on top. This sheaf serves as a roof to protect the sheaves from rain until they can be threshed. In areas where rain is not anticipated at harvest, six sheaves are set together with no sheaf on top. In some localities in the Philippines where rice is cut with a sickle and tied into sheaves by hand, about 25 sheaves are placed together to form a shock. On some farms the sheaves are hauled into a barn and threshed several months later. In other localities the thresher is brought to the field at harvest time and the sheaves are hauled from the shock directly to the thresher.

Reapers mounted on four-wheel farm tractors (Fig. 9.12) or designed as self-propelled machines are used when grain is endangered by hail, when weeds in the grain must be dried so that they can be separated by threshing, or when moisture-sensitive crops such as birdsfoot trefoil seed are harvested. Self-propelled reapers are also used when economic conditions preclude the cost of binder twine or combines, but a machine of more capacity than a pedestrian tractor reaper is required.

Self-propelled windrowers utilize moving canvas platforms to move the grain stalks from the sicklebar to the centerline of the machine, where the stalks are dropped into a windrow. Most tractor-mounted windrowers form the windrow at the side of the machine instead of the center. It is important when forming a windrow that the grain heads are all in the same direction and the stalks are more or less parallel.

9.12. Schematic of a tractor-mounted reaper.

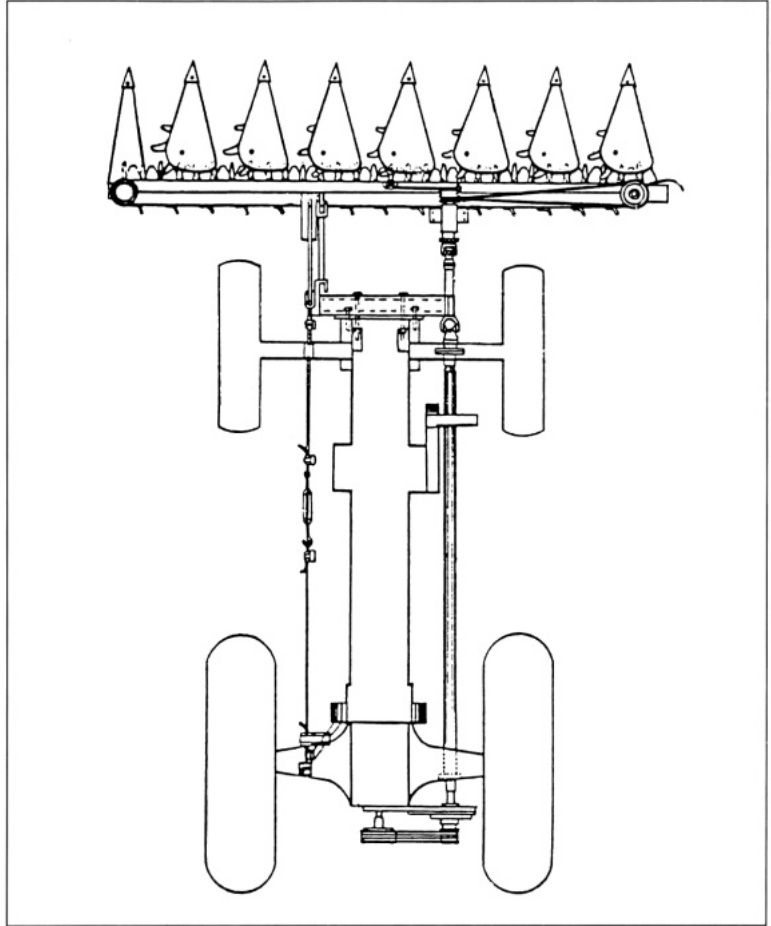

9.1.3 *Threshers.* In sections of Indonesia rice is threshed by men and women in bare feet, shuffling in the form of a dance upon sheaves of rice lying on a woven reed mat. Periodically, the straw and grain are removed from the mat, and unthreshed sheaves are added. Threshing rice by this means is possible because the rice is harvested by an ani-ani (see Fig. 9.1) and thus has very short stems. Furthermore, the sheaves are dried in the sun for a number of days before threshing. Rice is easier to thresh than most grains, and dry sheaves of rice are very easy to thresh.

Threshing by animal hooves on a hard clay floor is an ancient agricultural practice. Bullocks, water buffalo, donkeys, and burros are the most common animals used for threshing in this manner (Fig. 9.13).

9.13. Bullocks trampling out grain on threshing floor.



In using a threshing floor, sheaves of grain are laid out in a low cone about 4 m in diameter and ranging from a height of about 1.5 m at the center to a single layer of sheaves toward the edge. As the animals trample out the grain along the periphery of the circle, straw is removed and more sheaves are tossed under the animals' hooves.

Farm tractors have replaced animals on threshing floors in some countries. The tractor drives around and around the threshing floor, with the lugs of the pneumatic tires threshing out the grain. The method of removing the straw from the periphery and tossing unthreshed sheaves from the center remains the same. This is not an efficient use of tractor power, but tractors purchased for tillage or transport can be used for threshing with no modification of the traditional threshing floor, except that it is no longer necessary to scoop up animal droppings.

A study in Sri Lanka compared threshing rice on a threshing floor by water buffalo, a farm tractor, and a 5-hp mechanical thresher.³ The sheaves of grain were piled 5 ft (1.5 m) high in the center and out to a diameter of 12 ft (3.6 m). Five water buffalo were driven around and around at a speed of 2.25 mph (3.6 km/h) for the animal threshing test. The tractor threshing was done by a 45-hp farm tractor going

around and around at a speed of 5-10 mph (8-17 km/h). The thresher was a small axial-flow type, as shown in Figure 9.14, powered by a 5-hp engine. Results of the study are shown in Table 9.2.

Concrete and asphalt highways serve as long threshing floors, and passing cars, trucks, and buses as the threshing implements in many rural parts of the world. Sheaves of grain lying on the highway are threshed as they are rubbed between

3.14. Small axial-flow thresher with oscillating cleaning screens.

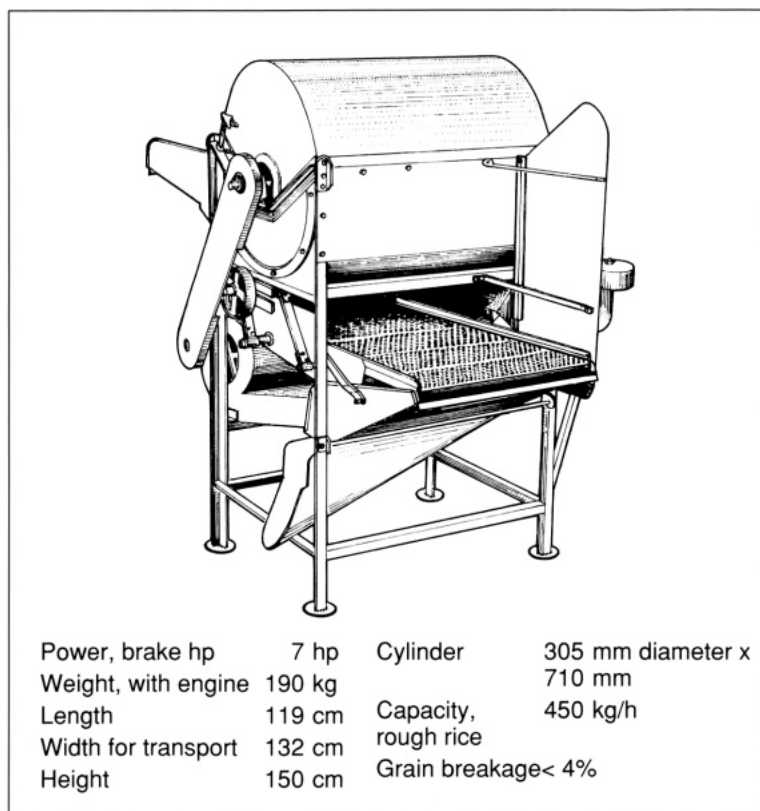

Table 9.2. Comparison of threshing floor and mechanical thresher.

Technique	Threshing rate kg grain/h	Threshing efficiency (%)	Threshing hours per ton of rough rice	Winnowing hours per ton of rough rice	Head rice loss (%)	Fuel in liters/t (US gal/t)
5 water buffalo	120	96.0	43.9	3.5	6.2	
45-hp farm tractor	2000	97.4	16.6	3.6	7.0	5.0 (1.3)
5-hp axial-flow thresher	400	99.9	10.1	0.9	0.7	3.5 (0.9)

the highway surface and the rubber tires of the vehicles. The work is not strenuous and is often done by young children or old persons. Not only do the tires of vehicles do the threshing, but the draft of fast-moving vehicles also blows away much of the chaff. This form of threshing can be dangerous, slows traffic, damages grain, and in many countries, e.g., China, is illegal. However, farmers without threshing equipment continue the practice, since it is easier and faster than flailing the grain out by hand. Local police do not enforce the ban on highway threshing, since they too are part of the local agricultural community.

The small mechanical thresher has the advantage that it can be carried to the ricefield so that sheaves need not be transported to the threshing area. The study reported in Table 9.2 was conducted where the field was 150 m away from the threshing floor; the small axial-flow thresher was operated in the field. For each ton of threshed rice, 37.7 h of labor were required to transport sheaves of grain to the threshing floor, while only 11.5 h were required for the thresher.⁴

In the 18th century, George Washington used horses pulling a center-pivoted roller to thresh grain on the second story of his barn. The threshing floor consisted of wooden planks set on edge with sufficient space between them to allow the grain to fall to the floor below.

Threshing rollers, threshing sleds, and disc threshers are used for threshing small grains. The Egyptian threshing sled does the job of 4 or 5 bullocks and cuts the straw into short pieces 1-2 cm long (Fig. 9.15). The straw, called *tiben* in Egypt and *bhusa* in India and Pakistan, is used as bullock feed. A typical Egyptian threshing sled is 107 cm wide and has 3 axles on 25-cm centers with four 45-cm-diameter 16-gauge (0.060 in) steel discs on each axle. The crop—usually wheat—is spread 30-50 cm deep for threshing. In India, a similar type of disc thresher is called an *olpad*.

The concept of threshing grain with a threshing roller on a threshing floor has been modernized, somewhat inefficiently, by some Pakistani farmers who use tractor-drawn disk harrows such as shown in Figure 4.26 to thresh wheat as their forefathers used bullock-drawn threshing rollers or disk threshers. These means of threshing do not completely separate the grain from the straw, and further winnowing is required.

9.15. Egyptian threshing sled.



Threshing machines are used to thresh small grains, grasses, sorghums, and legumes. Most are not designed to thresh maize. Threshers can be classified by power, throughput, cylinder type, number of cylinders, and the direction of material flow through the machine.

Threshing occurs as the grain passes between the rotating elements in the cylinder and the stationary elements of the concave. The primary types of cylinders are the wire loop, spike tooth, rasp bar, spring tooth, angle bar, and drummy.

The inexpensive wire loop cylinder (Fig. 9.8) is used almost exclusively for threshing rice.

Spike- (or peg-)tooth cylinders are used to thresh all small grains. These rugged threshers can be adjusted by removing or installing spikes on the cylinder, or by bolting stationary spikes to the concave. Peg-tooth cylinders break dry straw and make cleaning difficult. Although peg-tooth cylinders are still used with rice, they have been replaced by rasp bar types for other small grains and maize.

A rasp bar looks like a large, coarse file. Rasp bars work very well with most grains and can be adjusted to handle various moisture contents and grain sizes. However, they are expensive and difficult to manufacture.

Spring-tooth cylinders are used for easily damaged crops such as dry bean and peanut.

Inexpensive angle bar cylinders are usually faced with tough rubber strips and are used for small grains and small seeds.

Drummy threshers are used in India and Pakistan, where the thresher also reduces the straw to lengths of 1-2 cm. The drummy is constructed like a hammermill with a hardened steel plate on the end of each spoke. The cylinder works against a concave made of rigid steel bars. Threshing occurs when the rotating plates force the straw and grain through the concave grates. An aspirator then separates the kernels from the short pieces of straw. The drummy performs best in a very dry climate, where the straw is easily broken and reduced in size.

Most threshers have one cylinder. However, by placing two cylinders in tandem, it is possible to thresh difficult crops without excessive damage. The first cylinder handles the crop gently and causes little or no damage. The second cylinder is more aggressive, since it must thresh the stubborn grain. Quite often both cylinders are identical, except that the second cylinder is run at higher speed. Double drum wire loop threshers use this technique. Two-cylinder threshers designed for dry bean use a spring-tooth cylinder running at low speed as the first cylinder to avoid damaging the beans. A spike-tooth cylinder operated at high speed is used as the second cylinder to assure that all the beans are threshed.

Most threshers are designed to allow the straw to flow straight through the machine. The sheaves are fed into the front of the thresher, and the grain is removed as the crop passes between the cylinder and the concave. The threshing occurs in about 120° of cylinder arc. Reciprocating saw-toothed fins called straw walkers toss and fluff the straw mass to free kernels of grain and move the straw rearward to the end of the machine, where it is sucked up by a fan and blown onto a stack.

The axial-flow thresher (Fig. 9.14) was invented at IRRI in the Philippines as a low-powered thresher for rice. The sheaves are fed tangentially into the concave opening at one end of the cylinder. The cylinder is a conventional spike-tooth; however, stationary helical segments fixed above the cylinder move the straw axially because of the interaction between the teeth and the helical segments. Thus, instead of subjecting the crop to only 120° of threshing, it is subjected to perhaps 300°. Blades welded to the exit end of the cylinder expel the straw from the machine.

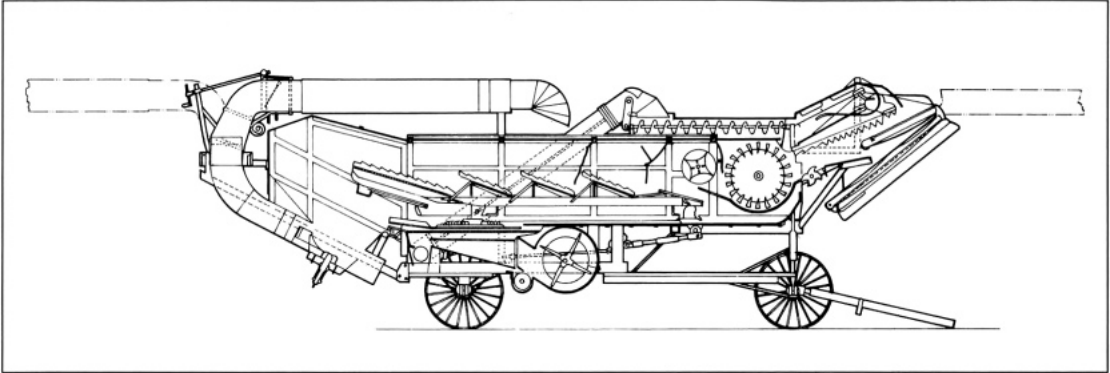

9.16. North American stationary threshing machine.

The stationary threshing machine (Fig. 9.16) is described by the diameter and length of the threshing cylinder (measured in inches); 20 x 28 and 40 x 62 are typical sizes. It performs the following operations:

- feeds sheaves into the machine,
- threshes out the grain.
- separates grain from the straw,
- cleans the grain,
- weighs and records grain weight, and
- blows straw and chaff into a stack.

The section of the threshing machine with the grain-cleaning sieves had the general outline of a shoe in early machines. Today the section of a threshing machine or combine with the sieves continues to be called the "shoe."

9.1.4 Combines. The combine is so named because it combines the reaper, the threshing machine, and the grain cleaner into one mobile machine. The first combines were drawn by tractors, horses, or mules, but today most combines are self-propelled. A conventional combine has the same arrangement as a stationary threshing machine: a threshing cylinder, straw walkers, cleaning shoe, and a fan.

A typical self-propelled combine (Fig. 9.17) weighs about 7.5 t. A full grain tank adds another ton. About 85% of the weight rests on the front drive wheels. Combines are steered by the rear wheels, which are often hydraulically powered to provide additional traction in mud.

The traction components of self-propelled combines are basically the same as those of tractors or trucks. The main exception is that most self-propelled combines use an adjust-

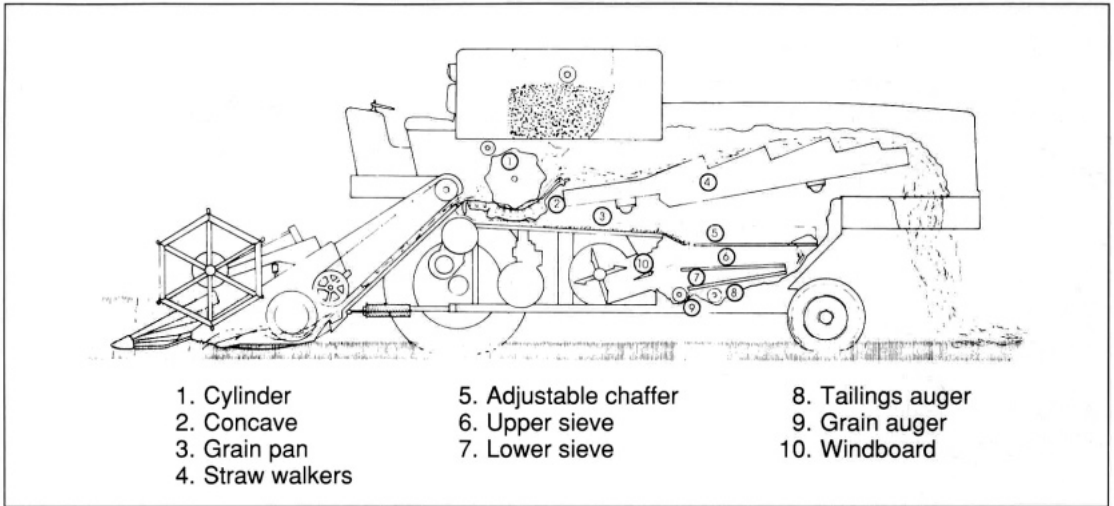

9.17. A conventional self-propelled combine.

able speed V-belt drive or a hydrostatic drive. The infinite speed range allows the speed of the combine to be matched to its capacity to harvest the grain.

When fields are soft and flotation is a problem, large-diameter pneumatic tires—sometimes called *rice tires*—can be installed. Alternately, dual tires can be installed on the driving wheels. When a combine is used on soft fields most of the time, it can be equipped with tracks instead of wheels. Tracks provide better flotation, but both the purchase price and the maintenance cost are higher than with pneumatic tires. Also, tracks do not allow high road speed. If poor flotation conditions are encountered only occasionally, half-tracks can be installed as a compromise.

The reaper function of the combine is performed by the *header*, the design of which depends on the crop. A header for small grains such as rice or wheat consists of a reciprocating knife to cut the crop, an auger to move the severed material to the feed opening, and a reel to assure that the severed stalks fall onto the header. The auger and the sheet metal supporting the cutter bar and reel are called the platform. The reel's height and speed are adjustable. Adjustments can be made from the cab by means of hydraulic controls in larger combines.

In areas where grain may be damaged by hail or green weeds, or must be threshed within a very narrow range of moisture, it is often windrowed and allowed to dry before

combining. Crops such as beans must be combined within a narrow moisture range and may be too dry to combine without excessive cracking in late afternoon, so the farmer allows the windrowed crop to absorb moisture from the night air, then combines the crop in the morning.

Windrows are gathered and fed onto the combine's platform by a *windrow pickup*, which consists of a wide belt with spring teeth. The entire unit is attached to the front of the header. A typical windrow pickup is 3.2 m wide. The speed of the pickup belt (also known as a draper) can be adjusted to the travel speed and crop condition.

Row crops such as maize are combined directly by attaching a snapping head—sometimes called a *maize (corn) head*—in place of the sickle bar header. Maize heads are manufactured in twos, fours, and eights for 75- to 100-cm row spacings.

A short *feeder-conveyor* moves the crop from the maize head or the platform to the threshing cylinder. The feeder-conveyor is usually a part of the base unit of the combine, whereas the maize head and the platform are attached to the feeder-conveyor housing.

Combines usually have a cab to protect the operator from dust, noise, rain, and cold. In hot climates the cab may be equipped with a fan or air conditioner. Since a large combine costs about \$100,000, it makes sense to place the operator in a comfortable environment. Besides the controls common to tractors and trucks, the following controls are located in the cabs of most self-propelled combines:

- pivoting ladder control
- unloading auger swing control
- grain tank unloading lever
- threshing cylinder speed control
- cylinder speed tachometer
- hydrostatic reel drive control
- header drive clutch
- separator control lever
- concave-cylinder clearance control
- header height control
- hydraulic lift reel control
- straw walker warning horn

Most combines collect the threshed grain in a tank that holds at least 1 t of grain. In regions where grain is transported

in bags, a bagging platform and a bag chute to drop the bag onto the field replace or supplement the grain tank and unloading auger.

Threshing occurs at the threshing cylinder. The types of cylinders are the same as those in stationary threshing machines—rasp bar, spike tooth, and angle bar. Some small Asian self-propelled combines for rice, such as the one illustrated in Figure 9.18, use a wire loop threshing cylinder. Others use a spike-tooth cylinder for harvesting rice.

The rasp bar is the most common type of threshing cylinder in combines. Besides the conventional rasp bar cylinder (where the material to be threshed is passed under and perpendicular to the cylinder and concave), the axial-flow cylinder is used on many combines because it provides greater threshing capacity without increasing the overall dimensions of the combine. Since the axial-flow design eliminates the need for a straw walker, the space formerly occupied by the walker can be used for threshing and separation. Because of the 360° between rotor and concave, the crop is subjected to a much longer period of threshing than in the conventional combine.

One self-propelled combine uses an axial-flow threshing cylinder similar to the IRRI design. Another uses 2 rotors, each one 43 cm (17 in) in diameter. One rotor turns clockwise and

9.18. Japanese self-propelled combine with two wire loop cylinders.⁵

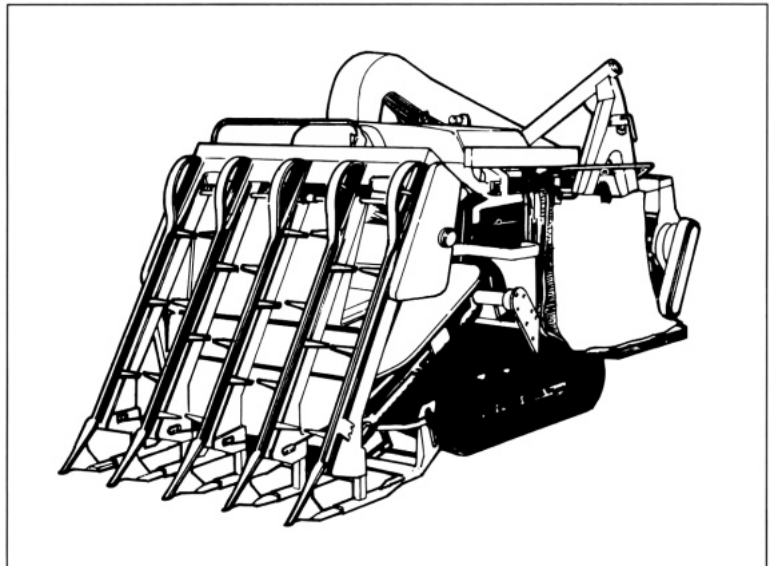

the other counterclockwise. Still another manufacturer uses 1 large rotor, 76 cm (30 in) in diameter. Most axial-flow combines perform a feeding function in the first 20% of the rotor length, thresh in the next 40%, and separate grain from straw in the last 40%.

Reciprocating straw walkers (as shown in Fig. 9.17) are used on most conventional combines, although a large European combine with a 1.58-m-wide (5.2-ft) threshing cylinder has 8 pairs of separating cylinders, one behind the other and in the same plane, to move straw rearward from the threshing cylinder and to save grain.⁶

Performance of a combine varies with the type of crop, weather conditions, and skill of the operator. It is impossible to operate a combine without grain loss. Some grain will not be picked up by the header, some will not be threshed, and some will ride out on top of the straw and become lost in the stubble. A 2-3% grain loss is acceptable; to reduce it further increases the cost of harvesting, since reducing the rate of harvesting costs more than the value of the grain saved. In the US, the top 10% of combine operators experience about 1.5% loss when combining maize and about 3-4% with soybean. The average combine is probably operated with a grain loss of 4-8% of the crop yield. To reduce grain losses and to operate at maximum efficiency, electronic grain loss sensors, straw walker overload warning sensors, and shaft speed monitors can be installed in the cab.

Hillside combines utilize a pendulum and hydraulic cylinders to keep the combine body level, even while the header and the tires remain in contact with the ground as the combine moves along the side of a steep hill. If the body of the combine is not level, the grain accumulates on the downhill side of the cleaning sieves, and the straw tends to overload the downhill side of the straw walkers. These conditions cause a loss of grain over the chaffer and out of the rear of the combine.

Three types of self-propelled combines are illustrated in Figures 9.19, 9.20, and 9.21.

A combine is similar to a good camera in that the various adjustments will provide good results if made correctly, but constant adjustment is necessary to meet changing conditions. When combining, adjustments must be made depending on the type of crop, grain moisture, amount of green

9.19. Self-propelled combine with tangential cylinder and straw walkers.⁷

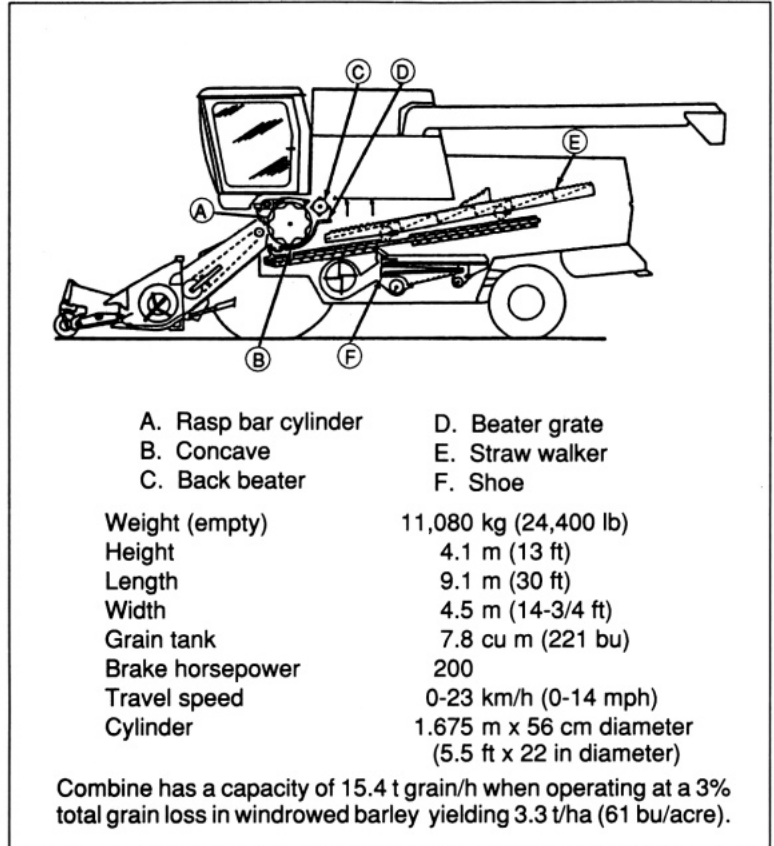

weeds, and crop yield. The major adjustments are made in cylinder or rotor speed, concave-cylinder clearance, chaffer opening, sieve opening, fan output, and travel speed.

For wheat, the peripheral velocity of the threshing cylinder should be 22-35 m/sec (4300-7000 ft/min [fpm]) and the concave-cylinder clearance 3-13 mm (1/8-1/2 in). For rice, the peripheral velocity should be 20-30 m/sec (4000-6000 fpm) and the clearance 1.5-13 mm (1/16-1/2 in). Beans require very low cylinder speed with a peripheral velocity of 7-20 m/sec (1400-4000 fpm) and a clearance of 13-25 mm (1/2-1 in). Clover seed requires high cylinder speed with a velocity of 25-41 m/sec (5000-8000 fpm) and a clearance of 3-10 mm (1/8-3/8 in).

During combining, moisture can be transferred from the straw to the grain, thereby increasing the moisture level in the grain tank 0.1-3% higher than in the kernels in the field.

3.20. Self-propelled combine with transverse axial-flow cylinder.⁸

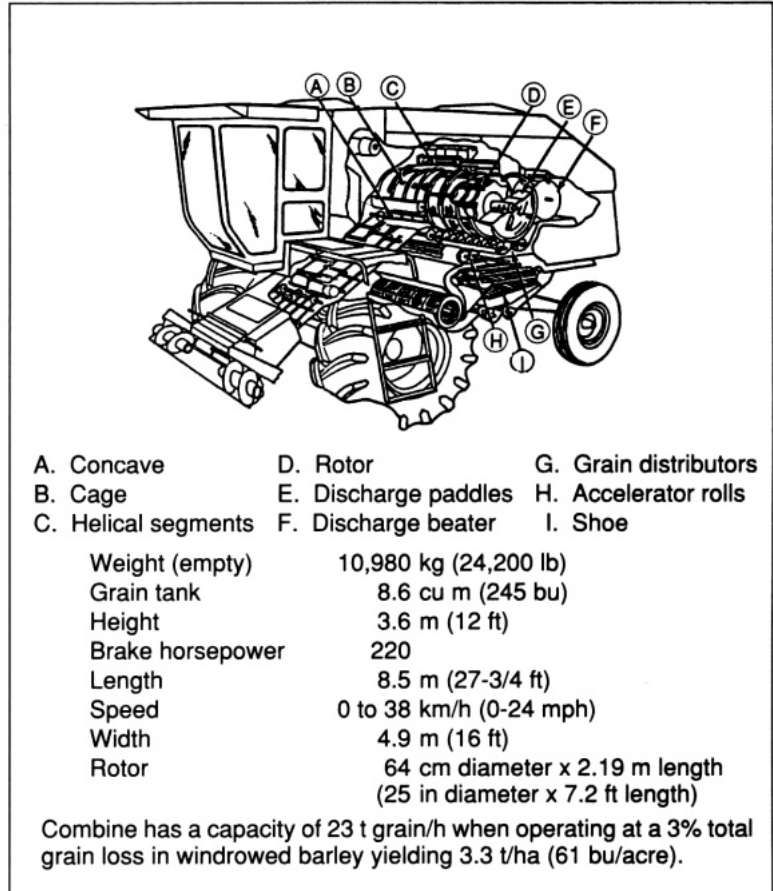

9.2 Root and tuber harvesting

Root and tuber crops such as Irish potato, sweet potato, yam, cocoyam, cassava, taro, peanut, and sugar beet are hidden from the farmer at harvest time. Unless the entire mass of earth about the tubers is lifted as a unit, tuber damage can easily occur.

Cassava is grown throughout the tropics and is usually harvested by hand. Since cassava tubers can be harvested over several months and are difficult to store, subsistence farmers harvest the tubers as required by digging them out of the soil with a machete and a hoe or a fork. In sandy soil, tubers can be lifted to the surface by the stem if some of the topsoil is first removed. The woody stem of a year-old cassava plant can transmit a maximum lifting force of about 1,500 N (337 lb) before breaking. To pull a cassava plant from sandy soil requires approximately 1,000 N (225 lb).

9.21. Self-propelled combine with longitudinal axial-flow cylinder.⁹

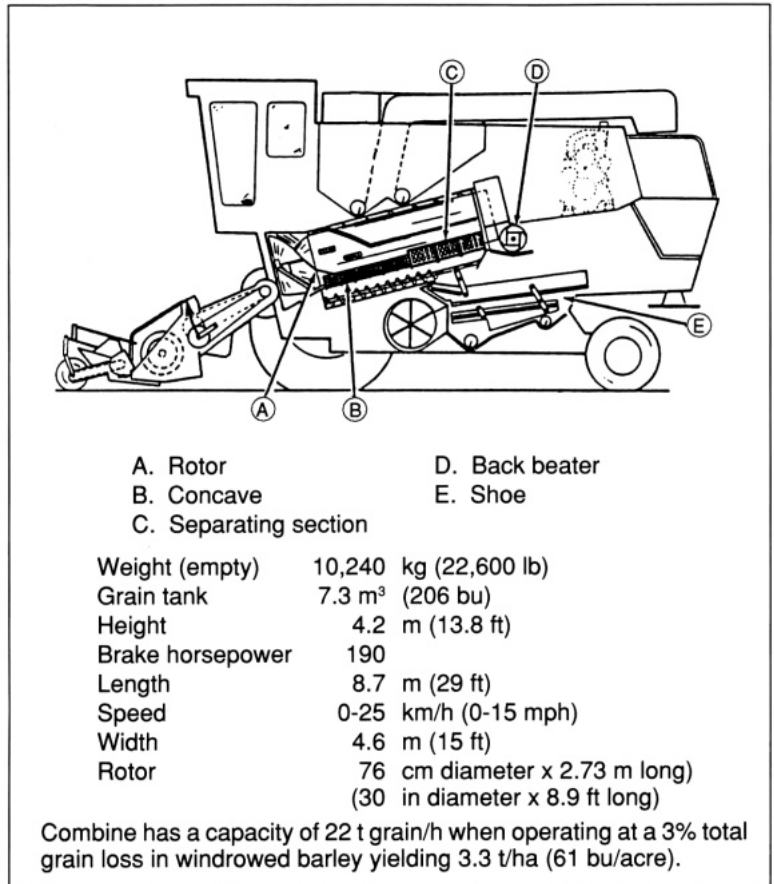

Experiments in Surinam with a two-person cassava lifter demonstrated that a simple cassava lifter was more effective than a spade in light soil. The lifter is simply a lever with a 3:1 mechanical advantage mounted on a stand. A pair of tongs hangs from the short end of the lever. One person places the jaws of the tongs around the cassava plant stem while the other person pushes down on the long end of the lever. Since a man can exert a downward force of 600 N (135 lb) with his body weight, the 3:1 mechanical advantage of the lever produces a lifting force of 1,800 N (405 lb) at the tongs. Table 9.3 provides a comparison of the two-person lifter and a fork for harvesting cassava.

A single-bottom moldboard plow can be used as a cassava lifter. If animals are used to pull the plow, they must be well trained. Studies in Fiji revealed that a single-bottom mold-

board plow mounted on a standard 3-point hitch of a 40-hp tractor was satisfactory for lifting cassava roots.¹⁰ Before plowing the cassava, the stalks were cut 10-15 cm above the soil surface. The short stem was used to pull the clump of tubers from the fractured soil after plowing. The aerial parts of the plant were tossed aside from the path of the tractor, which maintained a speed of about 3 km/h while plowing out the crop. The tubers were handpicked and tossed aside before being covered by the overturned soil. The Fiji experiments also tested a tractor-drawn disc plow and a hand fork. Test results are shown in Table 9.4.

Tractor-drawn cassava harvesters resemble the tractor-drawn potato diggers of the temperate regions. The simplest design is merely a lifting blade. A more mechanized design uses an inclined blade that passes under the cassava tubers. The tubers are loosened from the soil and lifted onto a moving conveyor chain or a reciprocating rack and are separated from the soil as the machine moves forward. The tubers fall off the end of the chain or rack onto the ground and are picked up manually. An even more sophisticated system features a side loading elevator at the end of the conveyor chain, which loads the tubers directly into wagons or trucks moving alongside the harvester.

Table 9.3. Comparison of fork and 2-person lifter for raising cassava.¹¹

Tool	Cutting off aerial parts (man-h/ha)	Lifting (man-h/ha)	Yield (t/ha)	Tubers left in soil (t/ha)	Tubers undamaged on lifted stems (t/ha)
Fork	30	180	49.7	6.1	39.7
Two-person lifter	30	120	47.3	2.6	44.6

Table 9.4. Comparison of methods of harvesting cassava in Fiji.

Item	Tractor and moldboard plow	Tractor and disc plow	Animal-drawn moldboard plow	Man with fork
Tubers exposed (kg)	115.6	71.1	53.0	59.7
Tuber damage (%)	1.4	7.8	25.0	5.2
Time required to harvest (h/ha) ^a	15	14	58	92
Persons required (no.)	2	2	2	1

^aDoes not include time for removing aerial parts.

In 1978, two cassava harvesters were evaluated at CIAT in Cali, Colombia.

The CIAT lifter was a two-row machine adapted to the three-point hitch of a category II tractor. Two inclined lifting planes, 50 cm wide on 1-m centers, corresponded to the row spacing. The planes elevated the tubers but did not separate them from the soil. Depth of work was controlled by the setting of the hydraulic lift.¹²

The second machine was the Australian Richter harvester. It is a category II, one-row, PTO-driven machine with a curved digger blade. A chain web elevator 1.6 m (5 ft) long directly behind the blade separated soil from the tubers as they were elevated about 50 cm above the ground. Depth of work was controlled by two adjustable land wheels at the rear of the machine.¹³

The harvesters were evaluated in 7-mo-old cassava planted on ridges, beds, and the flat. Several cassava varieties were planted. Row spacing of 1 m was maintained in both flat and ridge plots. Plant densities of 1,000, 5,000, 15,000, and 20,000 plants/ha were obtained by 200-cm, 66-cm, and 50-cm row spacing as well as by plant spacing within the row. The beds were 1.3 m (4 ft) wide on the soil surface, with 2 rows in each bed 90 cm (3 ft) apart. Plant spacings within rows were adjusted to provide the same densities as the flat and ridged plots. Before harvesting the cassava, the aerial parts of the plants were cut and removed from the field.

The following observations were made regarding the two machines.

- Both machines were effective under the test conditions. The chain web elevator on the Richter harvester laid the tubers on top of the ground, where the workers collecting them could easily find them.
- The small volume of soil displaced in the ridged plots minimized draft and energy requirements.
- Crop density did not appear to affect the quality of work, except that a higher density appeared to reduce crop damage by abrasion on the Richter elevator.
- Mechanical harvesters left two to three times fewer difficult-to-harvest tubers (tubers with a spreading type of root system) than did workers harvesting by hand. The opposite was true of the easy-to-harvest varieties,

which produce compact, conical tubers attached directly to the stem.

- Manual harvesting produced the least tuber damage.

Table 9.5 compares the harvesting machines with hand harvesting.

The mechanization of cassava harvesting requires modification of cultural practices in addition to alterations in harvesting tools and machines. Uniformity of tuber position in the row results in lower loss of tubers. Uniformity of position is enhanced by planting varieties with compact root systems, growing cassava on beds or ridges, removal of the aerial portions of the plants before harvest, and care in planting the stakes.

Potato harvesting can be by hand or by machine. A few potatoes can be removed from the soil by a person with a spade. Animals can be used to pull a single-row potato plow or an elevated potato digger (Fig. 9.22).

In many countries, potatoes are harvested with a farm tractor equipped with either a spinner, an elevated digger, or a potato harvester. A spinner is a tractor-mounted, PTO-powered machine consisting of a share to pass beneath the potato row and loosen the tubers, and an assembly of revolving tines that throw the loosened soil and potatoes to the side. Most of the potatoes land on top of the ground. The potato spinner is simple and works well in wet conditions. However, it can bruise the potatoes. Moreover, the potatoes are not laid in a compact windrow to facilitate manual picking. Potato spinners are common in Europe but have never been used commercially in North America.

Table 9.5. Comparison of manual and machine harvesting of cassava.

Variety	Harvest system	Yield (t/ha)	Leavings (t/ha)	Broken tubers (%)
MMEX 11 (difficult)	Manual	19.0	1.03	1.5
	CIAT		0.37	2.4
	Richter		0.58	7.6
CMC 84 (intermediate)	Manual	20.9	0.28	0.9
	CIAT		0.58	2.0
	Richter		0.68	6.9
MCOI (easy)	Manual	15.6	0.29	0.4
	CIAT		0.44	6.2
	Richter		0.42	11.2

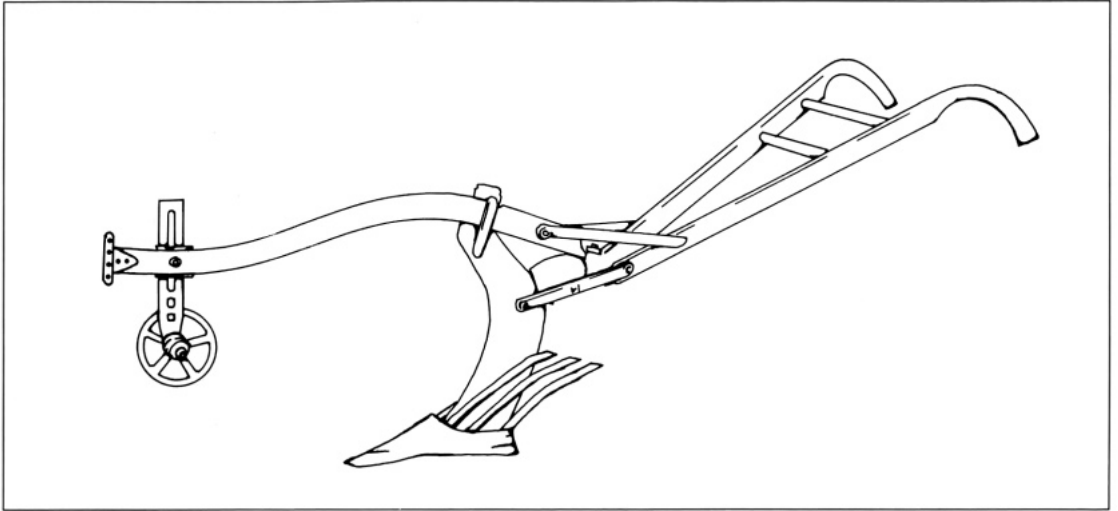

9.22. Animal-drawn potato plow.

An elevated digger has a broad share that slides under the row and loosens the tubers. Since the rear of the share is tilted upwards, the earth and tubers must be lifted by a steel elevator chain. The chain is shaken by agitator sprockets so that soil falls through the elevator as the potatoes are moved rearward. Chain speed is such that the potatoes and soil are moved rearward at the same speed that the digger moves forward. The agitator sprockets are selected according to the specific soil conditions and potato variety in order to obtain a windrow of soil-free potatoes with a minimum of bruising. Most elevator diggers are two-row machines, because when the tubers from two potato rows are placed in a single windrow, less labor is required to pick them.

The potato harvester is really a potato combine, since it combines the tasks of digging, picking, and sorting (Fig. 9.23). Most potato harvesters are 2-row machines pulled by a farm tractor of 75 hp or greater. A 2-row harvester traveling at 3.2 km/h (2 mph) with the blade 10 cm deep lifts 8-10 t of soil per minute. The common means of separating the tubers from the soil, stones, and clods is the tilted conveyor. This unit is a variable-tilt picking table manned by two to seven workers. Some potato harvesters use an air blast to remove light debris and flat stones. Other machines use rotary brushes to remove tuber-shaped rocks from tubers. The tubers ride atop the brush rollers, while the stones fall through the bristles to the ground.

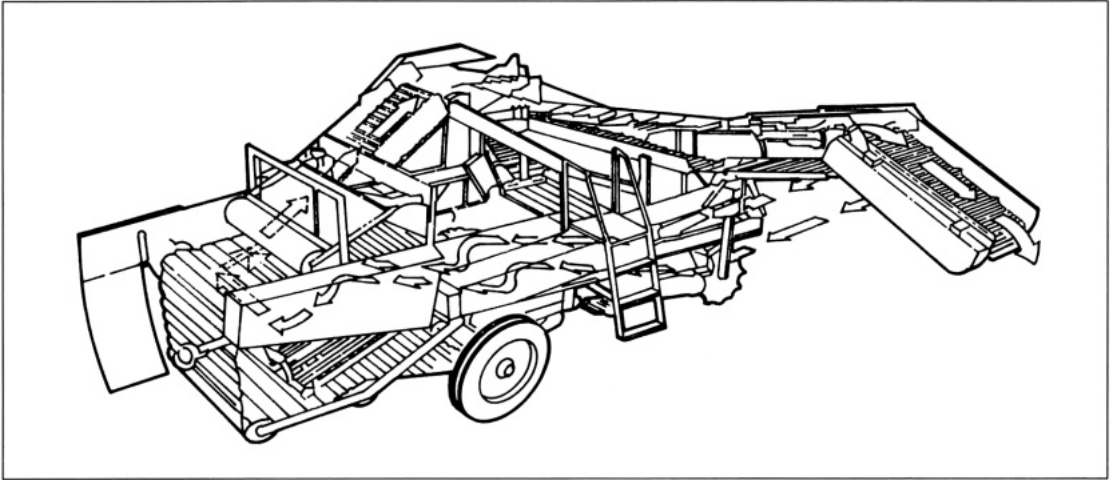

9.23. Potato harvester.

Liquid can also be used to separate tubers from stones. Although flotation is efficient in stationary installations, it has not proved successful on field machines. The flotation solution is heavy and cannot be maintained because of contamination with soil and debris in the field.

Some potato harvesters are equipped with X-ray sorters. A thin layer of material passes a bank of X-ray emitters, and corresponding sensors distinguish tubers from stones and clods. A commercial harvester uses a bank of 16 pairs of emitters, sensors, and pneumatically operated support fingers to distinguish a tuber from debris. When a tuber is identified by the X-ray sensor, it passes onto the conveyor. If the X-ray sensor identifies the object as debris, the corresponding support finger swings away, and the object drops to the ground.

Since it is crucial to use a ground speed that will provide the proper amount of soil and tubers on the primary apron, the tractor must have a transmission that will provide a large selection of gears. Tractors with hydrostatic transmissions are often preferred for operating potato harvesters.

9.3 Forage harvesting

Forage harvesting refers to the harvesting of grasses and legumes used in the form of fresh cut, hay, or ensiled fodder for animals.

9.3.1 Hand tools. Grasses and legumes are reaped with sickles or scythes similar to those used for harvesting grain,

except that these sickles are not usually serrated, and the scythes have shorter backs. A machete can also be used for harvesting forage. When cutting very flexible blades of forage with a machete, a stick is used to provide resistance to the impact of the blade.

9.3.2 Mowing machines. The reciprocating mower (Fig. 9.24) cuts like scissors by moving a section knife across a mating surface (ledger plate). It is the oldest and most common type of mowing machine. It is easily identified by the guards that separate the crop, lift lodged plants, shield the section knives at the end of the cutting stroke, and protect the knife from damage by rocks and rigid obstructions.

The reciprocating mower has low power requirements and is used for animal-power machines. Horse-drawn mowers normally have a 5 ft (1.5 m) cutter bar, while tractor mowers range from 5 to 9 ft (1.5-3 m). The knife cuts on both the outward and the return strokes. Throughout the world, knife sections are manufactured to a width of 3 in (7.6 cm), and the guards are spaced to the same measurement. Many mowers made for high-speed mowing have a stroke longer than the 3-in guard spacing. e.g., 3.75-4.75 in (9.5-12 cm). The knife moves through the crop at high velocity with the cutting side of the knife section within the lip of the guard at the

9.24. Reciprocating mower.

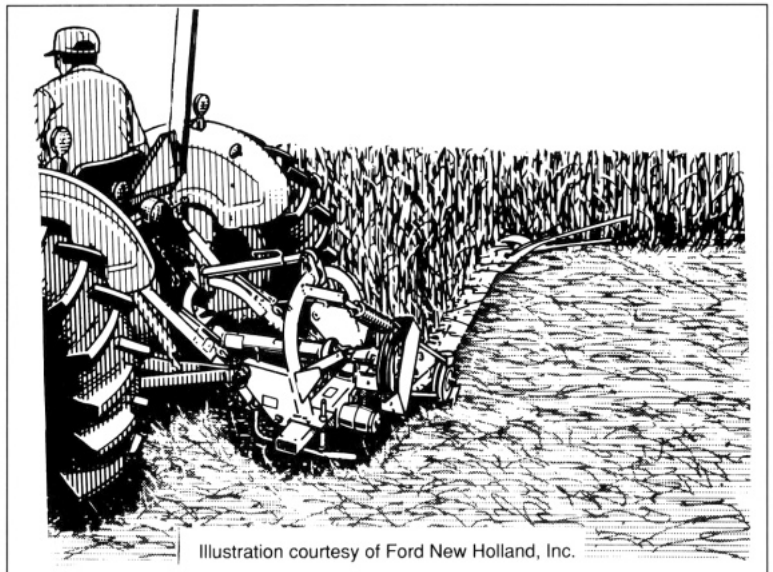

Illustration courtesy of Ford New Holland, Inc.

beginning and end of each stroke. Mowers with a long pitman usually operate at a crank speed of 700-1,000 rpm, while those using a rocker mechanism or a 2-throw crank drive the knife at speeds of 1,000-2,000 strokes/min.

It is essential that the knife section fit tightly against the ledger plates for smooth cutting. Otherwise, good cutting action is lost, and the crop clogs the guards. The cutting edges of the knife sections and the ledger plates must be kept sharp, and the guards must fit on the bar so that all of the ledger plates are on the same plane. A pry bar and heavy hammer are often used to nudge a guard into position. The knife is pressed onto the ledger plates by hold-down clips, which must be adjusted frequently.

The maximum forward speed of a reciprocating mower is greatly affected by the velocity of the knife moving across the ledger plates. The double-knife mower has two reciprocating knives, one above the other. When pressed together and held in position with a guide about every 15 cm (6 in), good cutting action between the upper and lower knife sections is obtained. The double-knife mower does not have guards. In smooth fields, it is able to mow heavy hay crops at high speed. Thick growth presents no difficulty to this mower. However, damage from large stones can occur since there are no guards. A test of a typical double-knife mower with a 1.5-m-wide cut revealed that the mower operates satisfactorily at speeds as high as 15 km/h.¹⁴ The speed and rate of work are about 50% higher than those of a conventional reciprocating mower under the same conditions. The operator's comfort and safety are quite often factors limiting travel speed. The double-knife mower is able to cut closer to the ground than the conventional reciprocating mower, and for this reason it is used where short stubble is desired.

Most tractor mowers connect the cutter bar behind for ease of attachment. Other mowers are mounted on the right-hand side of the tractor and forward of the driver. This arrangement makes it easy for the operator to watch the action of the mower and to make sharp turns. Mowers are occasionally mounted in front of the tractor for a few specialty crops. Break-away protection, which allows the cutter bar to swing rearward to prevent a damaging shock load should the cutter bar strike an immovable object, is difficult to design on a front-mounted mover.

Rotary mowers cut by impact rather than scissor action. Free-swinging knives about 7.5 cm (3 in) long do the cutting. The knives are mounted on from 2 to 6 high-speed drums or disks spinning at 1,800-4,000 rpm. Typically, three knives are mounted on the periphery of a disk. While cutting, the knives travel at about 340 km h. Rotary mowers are of three main types: disk, drum, and rear mounted.

The knives in disk mowers (Fig. 9.25) are driven by spur gears enclosed in a housing that resembles the cutter bar of a reciprocating mower.

Drum mowers (Fig. 9.26) are supported and driven from the top. Vertical cylinders (drums) support the driving mechanism 1.5-2 m above the ground and cut at ground level. Swinging knives are attached to the bottom of the drums. The rotors of disk and drum mowers are arranged in counter-rotating pairs for ease of manufacturing. The counter-rotating arrangement is normally satisfactory, although on some grass crops the pairs of drums tend to deposit the crop in rows instead of an even swath.

The rear-mounted rotary mower is used for trimming pastures and lawns. It usually has a vertical drive shaft with two heavy swinging blade attached to the bottom of the shaft. Centrifugal force throws cut herbage from below the sides and rear of the mower deck, which is attached to the tractor's three-point hitch.

Flail mowers have free-swining flails (knives) attached to a shaft mounted transversely at the rear of the tractor and powered by the tractor's PTO. A sheet metal hood over the shaft and flails directs the severed crop rearward into a swath and prevents stones and other objects from being thrown

9.25. Disk mower.

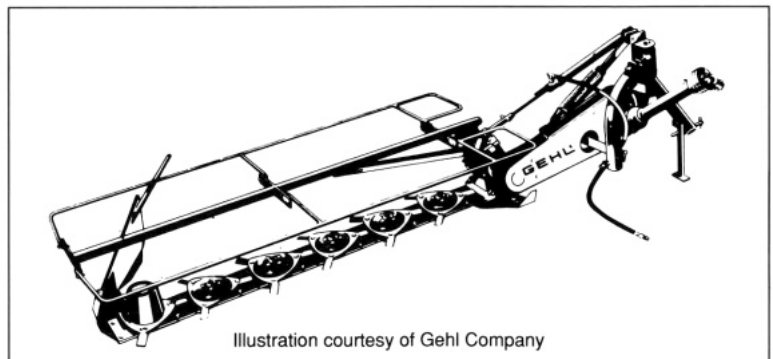

9.26. Drum mower.

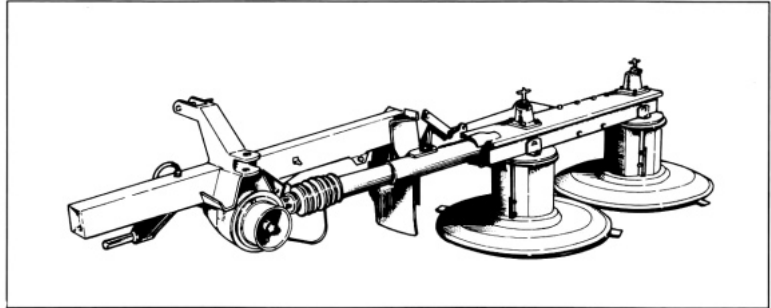

outside of the swath. The flail mower is very similar to a flail forage harvester, except that its rotor operates at a lower speed. Another difference is that the crop is placed into a swath instead of being blown through a discharge pipe. By placing retarding bars between the periphery of the flails and the hood, stems can be cracked and conditioned to enhance drying.

The power requirement for a rotary or disk mower is between that needed for a sickle bar reciprocating mower and that of a flail mower. For the same width of cut, a rotary mower requires five times as much power as a sickle bar mower, and two-thirds as much as a flail mower. The free-swinging knives that cut by impact give the rotary mower 2 important advantages over the conventional sickle bar: it can cut 70% faster and it cannot be clogged.

A rotary or flail mower is preferred with grass crops, in orchards where twigs and limbs are difficult for a sickle bar mower, where there are anthills or woodchuck mounds, or where the terrain is rough and the hay crop is frequently lodged. On the other hand, if the field is fairly smooth, the sickle-bar mower is preferred, since it requires less power, does not recut the crop, and has a low initial cost. Rotary and disk mowers have largely replaced double-knife mowers, since they are capable of mowing at high speed, and the cutting elements are much easier to replace than are the sickle knives of the double-knife mowers.

9.3.3 *Conditioners and rakes.* Grasses and legumes have high moisture content at mowing time. If the forage is to be stored as hay, it must be dried to 20% moisture content (MC). If it is to be stored as haylage (wilted hay crop silage), it should be dried to 55-65% MC. A tremendous amount of water must

be evaporated from a freshly cut hay crop to convert it to haylage or hay. Four tons of freshly cut grass or alfalfa at 80% MC must lose 2 t of water to wilt it to 60% MC before it can be stored as haylage. If the crop is to be made into hay, 3 t of water must be evaporated from 4 t of fresh material to obtain 1 t of hay at 20% MC.

To promote drying of the forage where no machines are available, farmers use hay forks to turn the bottom of the swath toward the sun and wind. The tedder is a machine that fluffs up the swath and rearranges the orientation of the leaves and stems to the sun and air. Tedders are drawn by both animals and tractors. The animal-drawn units are reel or kick type, in which the tines that lift and rearrange the hay crop are powered by the ground wheels.

The rotary tedder is tractor powered and available in both trailing and three-point hitch models (Fig. 9.27). In addition to tedding, most rotary tedders can form a swath into a windrow or spread a windrow into a swath. A typical reel tedder has a swath width of 2 m (6.5 ft), weighs 300 kg, and is operated at 10 km/h (6.2 mph). Rotary tedders are made for swaths from 1.5 to 6 m (5-20 ft) wide. A typical rotary tedder designed to work on a 3.5-m-wide swath weighs 250 kg and is operated at about 10 km/h (6 mph).

Tedders are more useful with grasses than with alfalfa, since they tend to knock leaves from the alfalfa stems and thus reduce its value.

Frequently the top part of a windrow of a drying hay crop is dry enough to bale, but the bottom is too wet. By inverting the windrow without tearing it apart as with a tedder, the wetter underside is exposed to the sun and air to dry, while the dry top surface is placed underneath. Windrows can be inverted by flipping them over with the end of side-delivery rake. A windrow inverter (Fig. 9.28) is designed specifically

9.27. Rotary tedder.

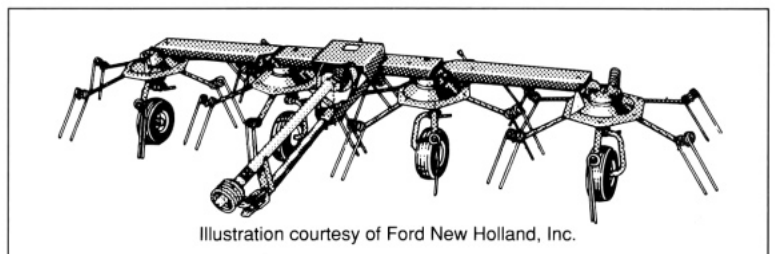

to turn windrows without much disturbance to the integrity of the windrow in a gentle fashion so that dry leaves will not be stripped away and the wet and dry materials are not mixed. The windrow inverter shown in Figure 9.28 uses a spring tine pickup to place the windrow on a transverse rubber belt that moves the hay to the side where, guided by deflectors, it forms an inverted windrow as it falls from the belt.

Research conducted in New York State with various types of tedders and conditioners to determine their effect in shortening the drying time for alfalfa revealed that

- crops cut with a mower-conditioner dried significantly faster than crops that had been mowed and tilled with a rotary or reel type tedder; and
- crops cut with a mower-conditioner and tilled dried significantly faster than crops not tilled.¹⁵

The tests revealed that 28 h after cutting, the crop that had been mowed and left in the swath had 27% MC; mowed and tilled twice, 25%; cut with a mower-conditioner, 22%; and cut with a mower-conditioner and tilled twice, 20%.

Where alfalfa is the hay crop, leaf loss, cost of tilling, and the marginal reduction of drying time do not justify the use of a tedder.

The drying of hay crops with hollow stems such as alfalfa is enhanced if the stem is crushed or crimped. Unless the stems are crushed or crimped, the leaves become overdry before the stems are dry enough to store. Smooth roll crushers that crush the entire length of stem are not as efficient as rubber roll crimpers. The crimpers provide more aggressive crop movement through the conditioning rolls. Also, it is

9.28. Windrow inverter.

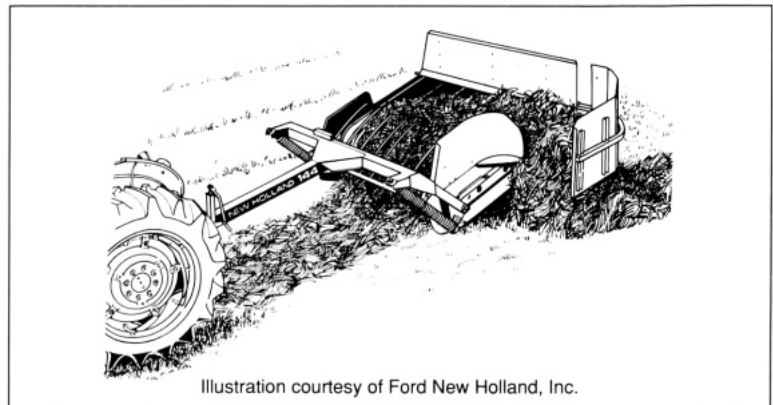

Illustration courtesy of Ford New Holland, Inc.

unnecessary to crush the stem, since crimping it about every 10 cm is satisfactory.

Some hay crop conditioners use swinging tines to abrade the stems so that moisture can move more easily through the epidermis. The tines are usually rubber-mounted steel bars or rigid-mounted plastic fingers.

Mower-conditioners combine mower, reel, conditioning rolls, and optional windrowing shields into a single tractor-powered or self-propelled machine (Fig. 9.29). The reel speed is extremely important, because it provides support for the standing crop while it keeps the cutter bar cleared of cut material, thus alleviating plugging of the sickle bar. The peripheral speed of the reel should be 10% greater than ground speed. Reel tooth action is usually controlled by an adjustable cam. Mower-conditioners are available with either reciprocating or disc mowing elements.

The mower-conditioner is a basic tool in North America and Europe for conserving the hay crop as hay or haylage. A comparison of mower-conditioners harvesting alfalfa in Wisconsin revealed that the unit with a disc-type cutter bar had a higher loss of material than the unit with a reciprocating sickle cutter bar: 5.9% total dry matter loss vs 3.9%. The unit with swinging rubber-mounted tines to condition the crop

9.29. Mower-conditioner.

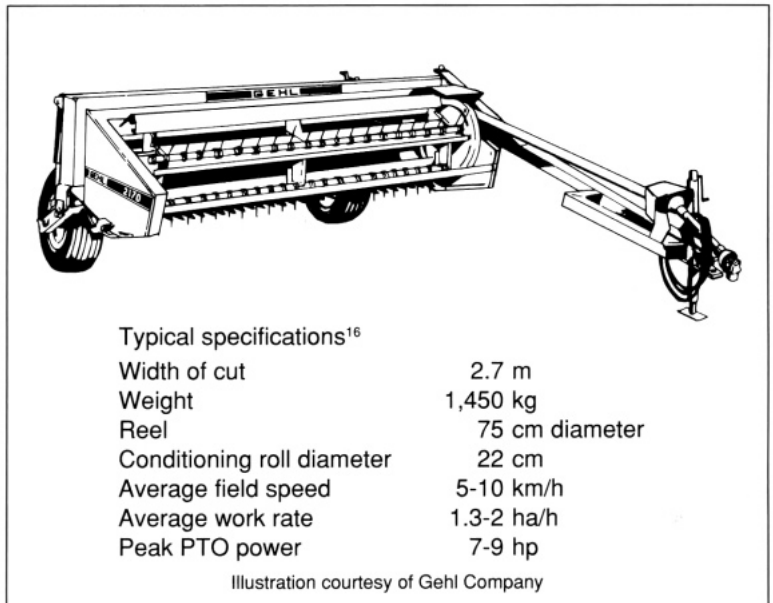

had a higher loss than the one using a pair of rubber flutes for crop conditioning: 7.2% vs 5.9%.¹⁷

In humid areas, grass or legumes grown for haylage are dried in the swath to about 40% MC, wet basis (wb), and are raked into a windrow, remaining there until dry enough to bale. In low-humidity areas, the forage is made into a loose windrow by the mower-conditioner and left to dry before baling. The various side-delivery rakes used for this purpose are cylindrical reel, oblique parallel bar, finger wheel, rotary, and transverse endless-chain types.

The cylindrical reel rake is usually ground driven, since it was first designed as a horse-drawn implement. This rake has spring tines on three or more reel bars, which move in a cylindrical pattern as they rotate about the center shaft. The reel bars and the basket in which they operate are towed at an angle to the swath. Thus, the interaction of the tines and the forward motion of the rake moves the hay to one end of the rake and deposits it as a windrow. Many models of cylindrical reel rakes can also be shifted into a tedder mode in which the swath is kicked out to the rear to form a loose swath. The cylindrical reel type rake is bulky and slow when compared to other rakes.

The oblique parallel bar rake (Fig. 9.30) is the most popular rake in North America. The bars are designed so that the tines remain nearly vertical as they descend into the swath, move sideward, and lift out. This rake forms a uniform

9.30. Oblique parallel bar rake.

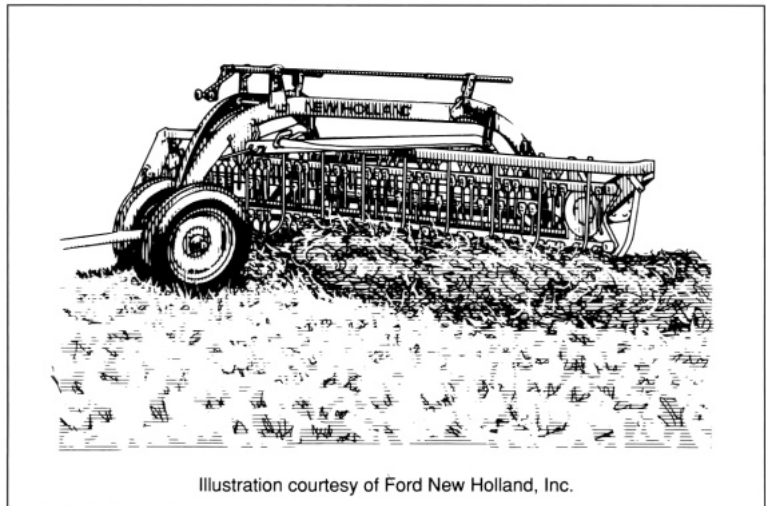

Illustration courtesy of Ford New Holland, Inc.

windrow, which is necessary to achieve high performance from a baler or forage harvester. Adjustments allow the tines to be tipped forward to make a loose, fluffy windrow, or tipped backward to make a tightly rolled windrow. Oblique parallel bar rakes are normally about 3 m wide and are operated at about 8 km/h (5 mph).

A finger wheel rake (Fig. 9.31) is very simple. It consists of a frame with a number of independently mounted, large-diameter wheels with spring teeth. The wheels are mounted slightly obliquely to the direction of travel and are rotated by the tines striking the swath. The wheels are spring-mounted so they can float and overlap, thus moving the hay sideways from one wheel to the other. This rake, is inexpensive and can be operated at 8-13 km/h (5-8 mph). A disadvantage of the finger wheel is that it picks up aftermath from previous crops, since the tines are in contact with the ground. Also, wind has a negative effect on the rake, since it blows some of the crop over the top of the finger wheels. Wind guards are sometimes installed to alleviate this condition.

The rotary rake is the most popular type in western Europe. This rake has spring tines mounted on stars, which rotate about vertical axes and are driven by a gearbox from the tractor's PTO. The rotary rake resembles a rotary tedder, and some models can easily be converted into either a tedder or a swath-turner. A typical rotary rake weighs 300 kg (660 lb) and has 4 rotary stars to provide a working width of 4.8 m (16 ft).

9.31. Finger wheel rake.

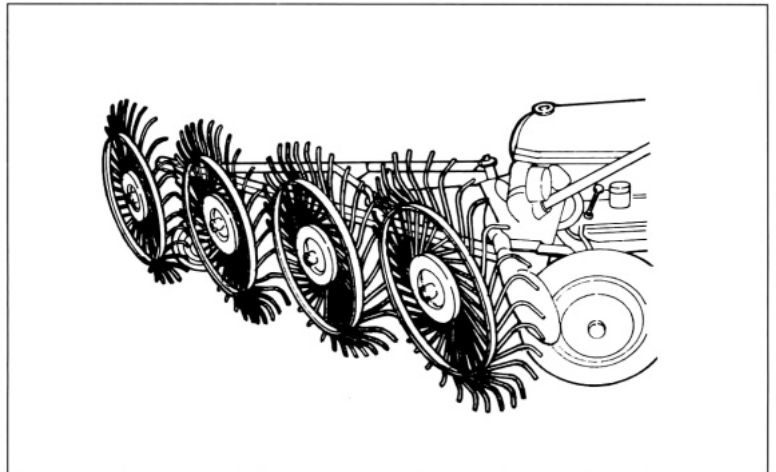

The transverse endless-chain type of side-delivery rake is a mounted PTO machine with a pair of chains running perpendicular to the direction of travel. Spring tines attached to the chains move the hay across the swath to form a windrow. This rake is not as simple or maintenance-free as the other rakes.

9.3.4 Forage harvesters. Forage harvesters are used to cut standing crops or to pick up windrows. Since the machines chop material into short lengths and then blow it 6-8 m (20-26 ft) into a wagon, they are normally powered by tractors of 60 hp or more. Only the multibottomed plow demands as much power as the forage harvester among ordinary farm machinery.

Forage harvesters are available in tractor-mounted, pull-behind, and self-propelled models. They are designed as base units with various attachments, commonly called *heads* in North America. The head is designed for gathering the crop and moving it to the cutterhead of the base unit. Common heads are the row crop, windrow pickup, direct cut, and snapper. The row crop head is for harvesting standing row crops such as maize, sorghum, and sunflower. The windrow pickup head is used to pick up forages such as alfalfa or grasses that have been placed into windrows. The direct cut head has a wide sickle bar and is used to cut a standing crop such as alfalfa. Direct cut heads are frequently used when alfalfa is cut for dehydration since it is important to shorten the time between standing crop and dehydration.

A flail forage harvester (Fig. 9.32) is the simplest and least expensive type of forage harvester. Farmers frequently use them for the daily chopping of fresh animal forage. The flail rotor is the heart of the flail harvester. Typically, the rotor is equipped with flails (knives) that cut a 2-m swath. The rotor is driven at about 1,500 rpm; thus, centrifugal force keeps the flails rigid as they sever the plants just above the soil surface. The flails are driven so that they move forward into the crop. Since the forage is usually longer than desired for silage, retarding bars are often placed on the inner surface of the rotor hood to reduce the forage length. The lacerated forage is thrown from the discharge spout by the energy imparted to it by the flails. The distance that the flails can throw the chopped material is often insufficient.

9.32. Flail forage harvester.

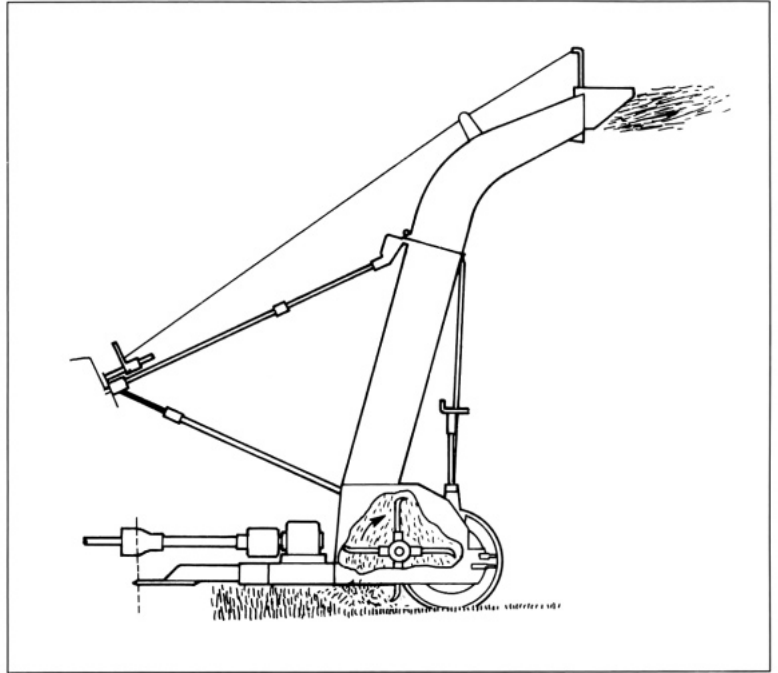

Flail harvesters equipped with blowers can throw the chopped material into the rear of a trailing wagon, even against the wind. By placing a transverse auger behind the flail rotor and a flywheel cutter-head at the exit end of the auger, a double-cut flail harvester is obtained (Fig. 9.33). It is possible to cut the long forage into shorter pieces and blow it with sufficient velocity into a trailing wagon. The cutterhead knives cut the forage into shorter pieces, but, since the material cannot be fed into the cutterhead at a uniform rate, it is not cut into uniform lengths. In fact, even with six cutterhead knives instead of three, the actual length of cut is not half as long as with the three knives.

Precision-cut forage harvesters have feed rolls that control the speed of forage through the cutterhead to obtain a uniform length of cut. The combination of cutterhead speed and the speed of the feed rolls controls the length of cut. Most precision-cut forage harvesters are set for a length of cut between 0.5 and 1.5 cm (3/16-5/8 in).

A cut-and-throw precision-cut forage harvester is designed so that the cutterhead throws the forage through the discharge spout and into a trailing wagon. When a higher

9.33. Double-cut flail forage harvester.

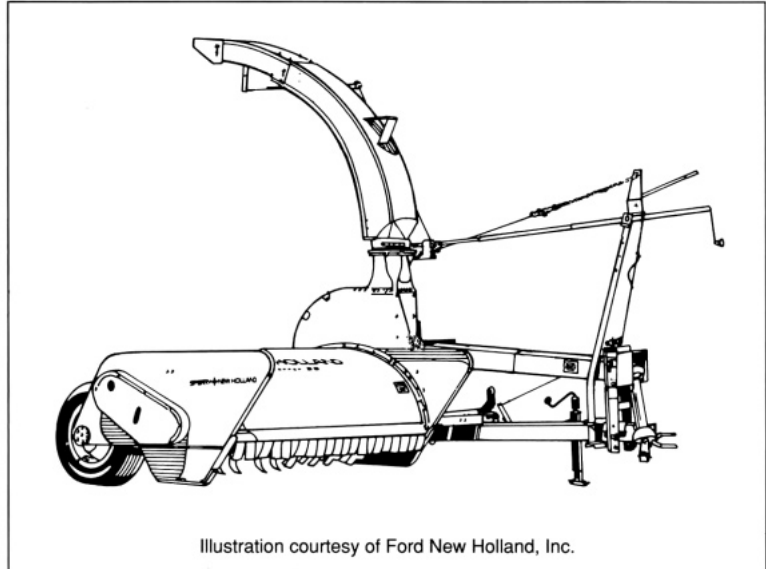

discharge velocity is desired, a forage harvester with a separate blower (cut-and-blow) should be used.

Several decades ago, most precision-cut forage harvesters utilized flywheel-type cutterheads (Fig. 9.34), because the first forage harvesters were merely ensilage cutters fitted with wheels and a row crop head. The flywheel-type cutterheads were satisfactory when the largest farm tractor was about 50 hp. However, as more power became available, and greater

9.34. Precision-cut flywheel-type forage harvester with row crop head.

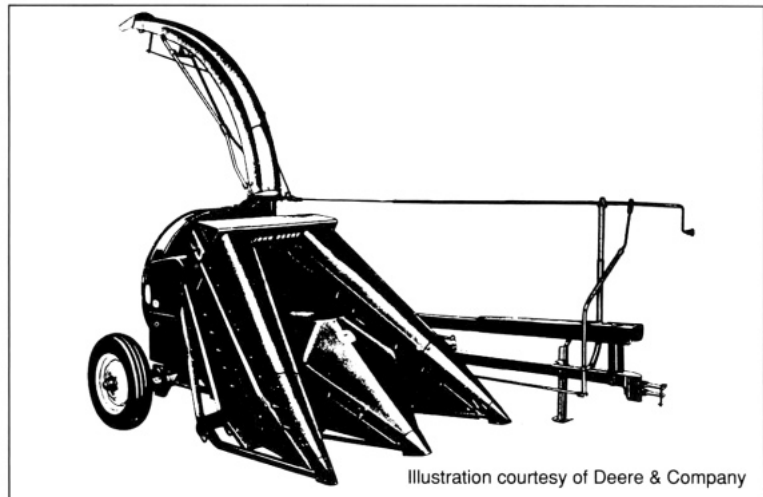

capacity was desired, larger machines were constructed. For each unit of increase of throat width, a flywheel cutterhead required two units of increase in diameter. Flywheel cutterheads became larger and more expensive. Although it is possible to make a thicker mat of material go through the cutterhead, better cutting action is obtained when the mat is thin. Manufacturers gradually moved from flywheel to cylindrical cutterheads (Fig. 7.35). A cylindrical cutterhead can run at higher speed and be made wider than a flywheel type, thus obtaining a short length of cut with a thin mat of material. Power consumption by a forage harvester according to function is shown in Figure 9.36. The figure is for a flywheel-type forage harvester cutting maize at a rate of 16.4 t/h with a 1.25-cm length of cut.¹⁸

A precision-cut cutterhead cuts with a scissors action. To retain nonragged particles, the knives and the stationary shear bar must be kept sharp and properly adjusted. About two-thirds of the energy consumed by a flywheel type or a cut-and-throw type of precision-cut forage harvester is by the cutterhead (Fig. 9.36); however, dull knives or a poorly adjusted shear bar can increase power consumption significantly. It is necessary to remove the knives from a flywheel cutterhead to sharpen them—not an easy task. Cylindrical cutterheads are designed so that the knives can be sharpened in the machine. The cutterhead is powered at low speed while a sharpening stone is moved across the cutting edges.

9.35. Precision-cut cylinder-type forage harvester and windrow pickup.

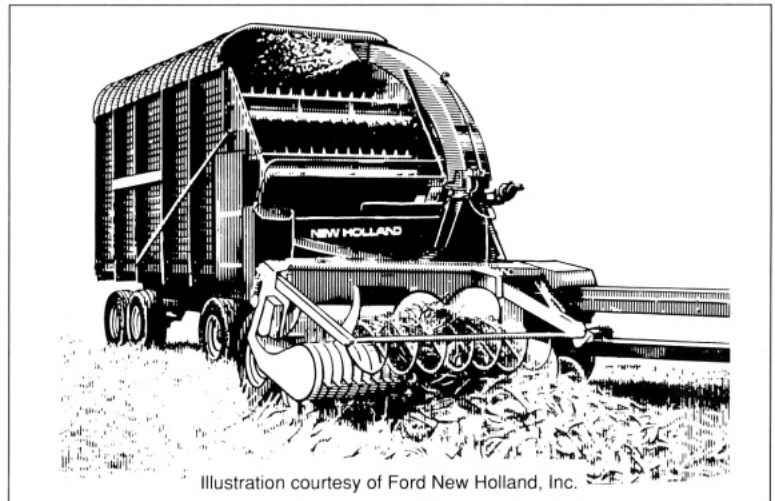
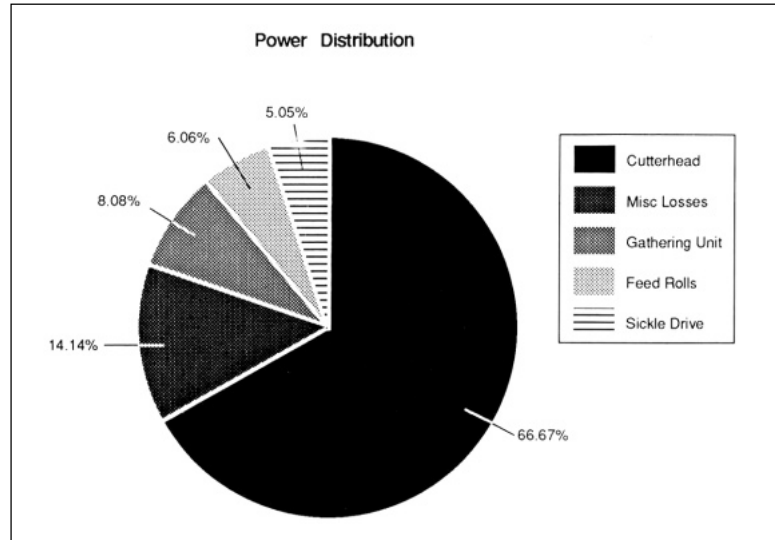

Illustration courtesy of Ford New Holland, Inc.

9.36. Power needs by a flywheel-type forage harvester.



Precision-cut forage harvesters are used primarily to harvest forage for storage in silos. Since silo unloaders for tower silos require a short length of cut to operate satisfactorily, precision-cut harvester must be used to harvest forage to be stored in tower silo.

To produce a finer chopped material than is possible with knife speed and feed roll speed combinations, a recutting screen can be installed in a cut-and-blow harvester. Recutting screens are heavy, curved, perforated steel plates similar to hammermill screens. They fit closely behind and below the cylindrical cutterhead and are available with hole sizes ranging from 1 to 10 cm (3/8-4 in) in diameter. A shorter length of cut is obtained, but at the expense of more power. Since forage harvesters are normally operated at full horsepower, the installation of a recutting screen reduces the harvesting rate.

A forage harvester equipped with snapper-head attachments can be used to snap maize ears and grind them into a maize and cob mix. The attachments are usually combine snapper heads adapted for use with forage harvesters. Snapper heads are available only for cut-and-blow machines with recutter screens

9.3.5 *Hay balers.* Baling is a method of packaging hay so that it can be stacked and handled by machinery. The bulk density

of the bale is important because it affects storage and transportation costs. If the hayfield is close to the storage facility, low-density bales of long, loose hay are desirable. When the bales must be shipped hundreds or thousands of kilometers, the hay is formed into cubes or wafers. Bulk densities of typical hay packages are shown in Table 9.6.

The three major types of pickup hay balers are those for small rectangular bales (Fig. 9.37), large rectangular bales (Fig. 9.38), and large round bales (Fig. 9.39). Rectangular bales have adjustments to vary the length of the bale, but the

Table 9.6. Bulk densities of various forms of packaging hay.

Hay package	Bulk density in	
	kg/m ³	(lb-ft ³)
Long loose hay	30 - 60	(2 - 4)
Chopped hay	60 - 100	(4 - 6)
Baled hay	100 - 200	(6 - 12)
Grass silage (haylage)	150 - 250	(9 - 16)
Cubed hay	375 - 700	(23 - 44)

9.37. Pickup baler for making small rectangular bales.¹⁹

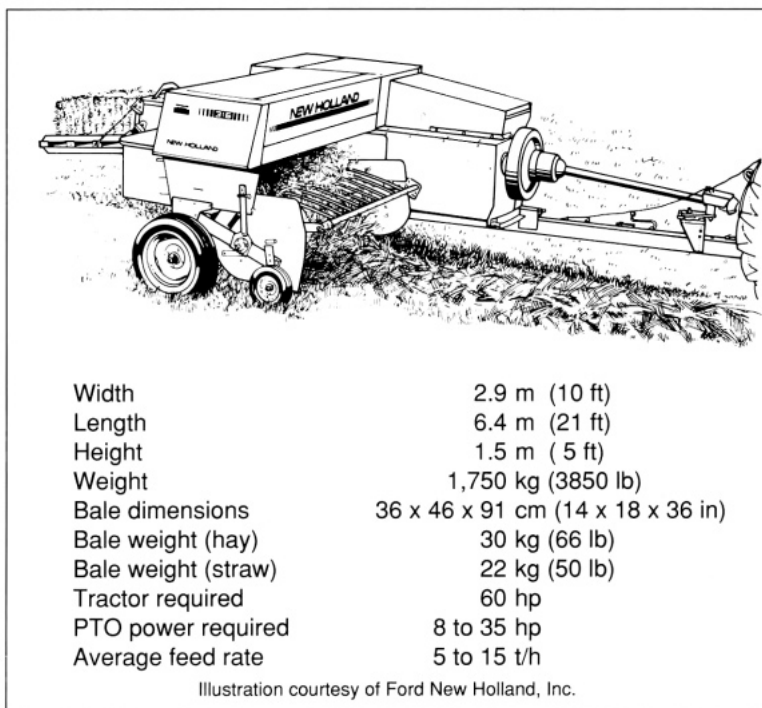

9.38. Pickup baler for making large rectangular bales.

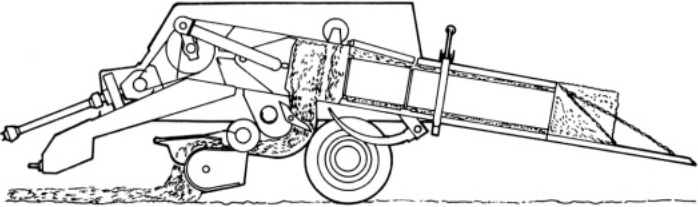

Width	2.8 m (9 ft)
Length	3.7 m (12 ft)
Height	3.2 m (10.5 ft)
Weight	7,800 kg (17,200 lb)
Bale dimensions	1.2 x 1.3 x 2.4 m (48 x 50 x 94 in)
Bale weight (hay)	900 kg (2000 lb)
Bale weight (straw)	650 kg (1433)
Tractor required	125 hp
Average feed rate	18 t/h

9.39. Variable chamber baler for making large round bales.

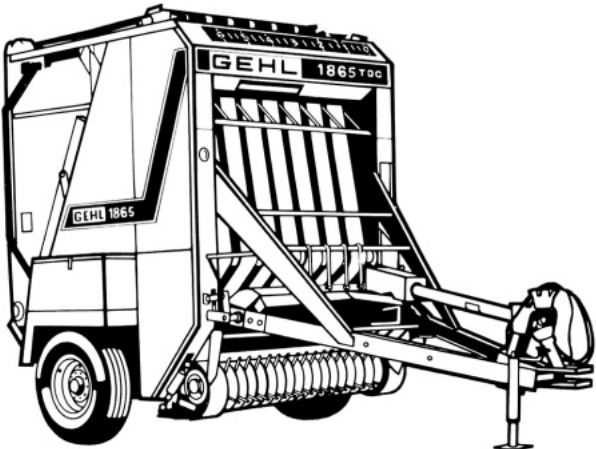

Width	2.6 m (8.5 ft)
Length	4.0 m (13 ft)
Height	2.4 m (7.9 ft)
Weight	1,750 kg (3850 lb)
Bale dimensions	170 x 170 cm dia (67 x 67 in dia)
Bale weight (hay)	800 kg (1760 lb)
Tractor required	60 hp
PTO power required	8 to 35 hp
Average feed rate	5 to 15 t/h

Illustration courtesy of Gehl Company

cross-sectional dimensions are determined by the bale chamber and cannot be altered. The standard cross-sectional dimensions for balers making small rectangular bales are 14 x 18 in, 16 x 18 in, and 16 x 23 in (35 x 46, 40 x 46, 40 x 58 cm). The length of small rectangular bales can be adjusted from about 30 to 125 cm (12-48 in). Two strands of twine or wire are used to keep the bale compressed and to retain its shape. The strands are usually against the larger cross-sectional dimension of the bale.

Large rectangular bales cannot be handled manually because of their size and weight. Cross-sectional dimensions of large rectangular bales range from 80 x 80 cm (32 x 32 in) to 120 x 125 cm (47 x 49 in). Five to six strands of twine are used to hold a bale together.

If a rectangular bale is stored outdoors for several months in a humid climate, it will mold and rot, since it cannot shed rain or snow. The round bale was developed for outside storage of winter feed. In some areas, bales are left where ejected from the baler, and are used for winter feeding months later. The hay forming the cylindrical surface in round bales serves as a thatched roof to the rain and snow. There is some deterioration of the outside 15 cm (6 in), but the bulk of the hay remains in good condition. The Storage loss of a large round alfalfa or mixed hay bale stored inside a barn is about 3% of dry bale weight. The same bale stored outside for 6 mo in humid temperate climate will lose about 15%.²⁰

Although balers have been developed for making small round bales—35-50 cm in diameter x 90 cm in length (14-20 x 36 in), weighing 20-45 kg (44-100 lb)—they are no longer commonly used. One type of baler is a very simple machine that forms the bale by rolling the windrow between the baler and the ground. Because the bale is formed on the ground, the baler cannot carry the bale, but must leave it behind. These bales are about 2 m in diameter by 2.1 m long, weigh 500 kg, and have a density of about 100 kg/m³.

Another type of round baler picks up the windrow and feeds it between sets of belts, chains, or powered rollers to form the bale. The belt- or chain-type bales are usually variable chamber machines, while the powered roller balers are usually fixed chamber machines. The variable chamber machines can make bales of various diameters, while fixed chamber balers make only one size bale.

The ends of most round bales are not tied with knots. The twine is merely wrapped on the bale while it is compressed and rotating in the chamber.

The PTO power requirements for a large round baler are fairly constant. A typical baler consumes 4 hp at no load. As hay is fed into the chamber, the PTO power increases to about 15 hp as the bale weight increases to 100 kg (220 lb). The power requirement remains constant as the bale weight increases to about 300 kg (660 lb), and then rises to 20 hp as the bale approaches a weight of 400 kg (880 lb). About 10 dwb hp is required for a large round baler traveling at 10 km/h (16 mph) on a dry flat field.

9.4 Fiber harvesting and field processing

9.4.1 Cotton. Cotton is a perennial crop, but it can be grown as an annual. The fibers that grow from the seed coat are called *lint*. These fibers are the most valuable part of the plant, although the seeds are also valuable, since they are about 20% oil by weight. The seed and lint are contained in a seed pod called a *boll* (Fig. 9.40). Each boll contains four or five clumps called *locks*, which contain the seeds and lint. The seeds and attached lint are called *seed cotton*.

Cotton can produce up to 3300 kg seed cotton/ha (3000 lb/acre), but the yield is more commonly 1,500 kg/ha (1340 lb/acre), and in primitive conditions it is often as little as 300 kg/ha (268 lb/acre).

Traditionally, cotton is handpicked. A good worker can pick 45 kg (100 lb) of seed cotton per day in a heavy crop, but on poorer yields the average is probably 10 kg (22 lb) per picker per day. Unfortunately, cotton bolls do not open uniformly, so a field must be picked three or four times weekly. Cotton should be dry before it is picked. The picker pulls a sack that can be up to 2 m long. The open end of the sack is tied to the picker's waist so that both hands are free to pick the cotton. Cotton pickers are usually paid by the weight of seed cotton picked. After weighing, the cotton is put into 30-kg (66-lb) bags and transported to a cotton gin, where the lint is removed from the seeds. The lint is baled into 227-kg (500-lb) bales.



9.40. Ripe cotton boll ready to harvest.

The disadvantage of harvesting cotton mechanically is that it usually results in an accumulation of trash—pieces of leaves, stems, and unopened bolls. The gin must therefore remove the additional trash. There is no difficulty in ginning

handpicked cotton in a gin designed for mechanically harvested cotton, but cotton from a mechanical harvester can cause difficulties in a gin designed for handpicked cotton. An example of a mechanized cotton picker is shown in Figure 9.41.

Chemical defoliant is necessary in harvesting cotton mechanically. Defoliation removes leaves, which interfere with machine harvesting, prevents staining of the lint by green leaves, and eliminates dry leaf trash, which is difficult to remove.

Mechanical cotton pickers are of two types: stripper harvesters and spindle pickers. Stripper harvesters operate best with low-growing, short-limbed plants. At first glance, a cotton stripper resembles a maize snapping head for a combine or maize picker. For each row there is a pair of stripping rolls about 15 cm in diameter, 1 m long, and set at about 30° to the horizontal (Fig. 9.42). The rolls consist of alternate longitudinal rows of brushes and rubber flaps. The rolls are driven so that they pull up on the plant (opposite to the direction of rotation of snapping rolls on a maize harvesting head). The stripper rolls snap off the cotton bolls, which are discharged into conveying augers and then into an airstream, which separates the mature bolls from the green, unopened bolls by blowing them into a storage basket.

Gin turn-out is the weight of recovered lint divided by the weight of field-run seed cotton and expressed as a percentage. It is sometimes used as an index of the efficiency of the

9.41. Self-propelled spindle-type cotton picker.

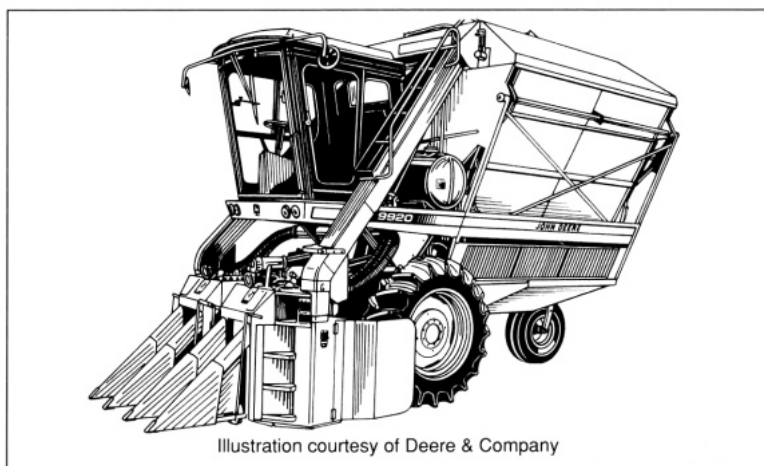
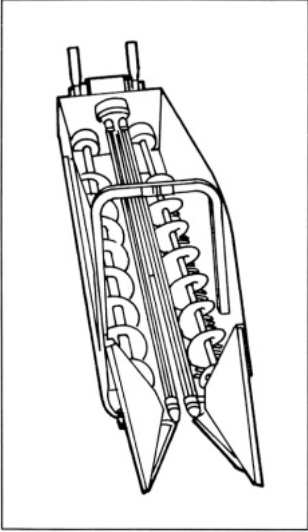

Illustration courtesy of Deere & Company



9.42. Stripping rolls of a cotton stripper.

harvesting system. In a test of harvesting systems, the gin turn-out for hand picking was 37%; spindle picker, 36%; and stripper harvester, 23%.²¹

Instead of pulling the cotton bolls from the plant, the spindle picker uses revolving spindles to penetrate the plant. The seed cotton is then wound upon the spindles. In some machines, the spindles are tapered with three or four longitudinal rows of barbs (Fig. 9.3). The barbs on the spindles snag the cotton, which is pulled from the bolls and wound on the spindles as they rotate at 2,000-4,000 rpm. Other machines use straight spindles with circular or square cross sections (Fig. 9.44). Their cross-sectional area is smaller than that of the tapered spindles, and they rotate at about 1,500 rpm. Both straight and tapered spindles must be moistened with water, since a wet steel spindle adheres to cotton better than a dry spindle, and the water keeps the spindles clean of gum and dust.

Figure 9.43 shows tapered spindles mounted on a drum. The peripheral speed of the drum is the same as the ground speed of the machine. There are 2 drums per row, with a total of 500-600 spindles. Cotton is removed from the tapered spindles by powered doffer plates.

Some chain-belt types of spindle pickers are designed to pick from only one side of the row, while other machines are designed so the the row passes between a set of belts holding

9.43. Top view of spindle picker, drum type. with tapered spindles.

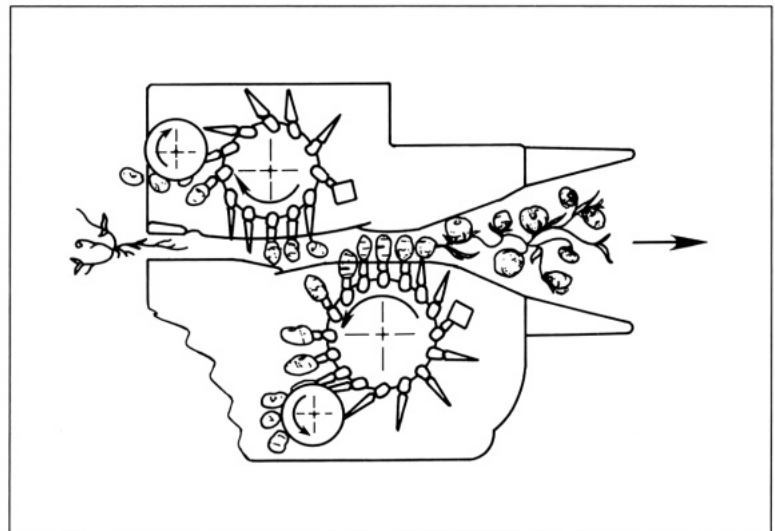

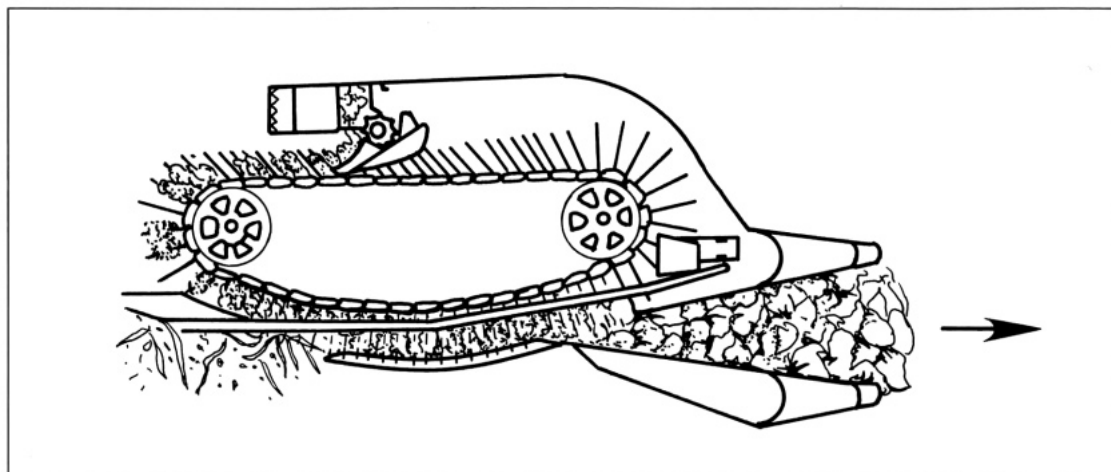

9.44. Top view of spindle picker, chain type, with straight spindles.

spindles. A chain type of spindle picker with straight spindles, as illustrated in Figure 9.44, may have nearly 1,300 spindles. The spindles rotate only while passing through the cotton foliage. On the return side, the spindles are not rotated and the cotton is stripped as the spindles pass between the teeth of stationary strippers.

9.4.2 Jute. Jute (*Corchorus capsularis* or *Corchorus olitorius*) ranks second to cotton in importance as a fiber plant. A jute stalk at harvest time is 3-4 m high, with a diameter about that of a man's small finger. The stalks are harvested between the time of blooming and the appearance of the seed capsules. Harvesting is usually accomplished by workers with hand sickles, who sever the stalks 3-5 cm above the soil surface. Jute is produced mainly in the river deltas of Bangladesh. It is often harvested while partially submerged by the annual monsoon floods. Since the jute plant has a very small root system, partially submerged plants are harvested roots and all. The roots are cut off later on dry ground.

Jute yields about 28,000 kg/ha of green crop, although under excellent conditions, yields of 45,000 kg/ha are possible. Since the extracted dry fiber by weight is about 4-4.5% of the green crop, a normal crop yields about 1,400 kg dry fiber/ha.²²

Harvesting of jute goes hand in hand with primary processing. Jute fibers are located in the cylindrical stalks between the epidermis and a central woody core. The fibers

are detached from each other, the woody core, and the bark by immersing the stalks in water for a period of days. This process is called *retting*. Sometimes jute fanners set up the stalks in shocks to dry for several days before retting. Other farmers take their crop directly to the water, where a raft of 10-15 bundles of stalks with 50-100 stalks/bundle is placed in the water. Weight is placed on top of the raft to force the stalks underwater. After 8-10 d, the fermentation progresses to a stage where the fibers are flexible and can be separated from the stalk. The stalks are removed from the bundles, and workers pull the fibers from the stalks with their hands. The process can be expedited by using a wooden mallet. The fibers are washed in the water and hung up to dry in the sun. An experienced person can extract about 3 kg of dry fiber per hour.

Machines have been developed to partially decorticate jute stalks before retting. By machine extraction, the fiber-bearing strips are made uniform, and retting is uniform throughout the length of the strip, whereas in traditional retting the thinner tops ret early while the thicker base of the plant is only partially retted. Machine decortication before retting reduces retting time to 5-6 d, provides more uniform fibers, and reduces labor.²³

9.4.3 Kenaf. Kenaf (*Hibiscus cannabinus*) is used as a substitute for jute. It has more luster than jute, but is coarser and less supple. In the 19th century and during World War I, one variety (*Cannabis sativa*) was grown in the United States as a source of cordage. Kenaf is an annual crop with a single stem about 4 m high. Harvesting and primary processing of kenaf are identical to that of jute.

9.4.4 Flax. Flax (*Linum usitatissimum*), a fiber crop of the temperate zone, is the plant from which linen is made. The fibers are located in the stem between the epidermis and a central wooden core. At harvest, the flax plant is 50-100 cm high.

Flax harvesting and primary processing consist of six steps:

- | | |
|---------------|--------------|
| 1. harvesting | 4. drying |
| 2. deseeding | 5. scutching |
| 3. retting | 6. combing |

These operations may consume 1.5-2 yr. Although this length of time could be greatly shortened by artificial drying, the weather and the agricultural work load patterns where flax is grown determine a long time period.

Flax harvest is traditionally accomplished by pulling the plants out by the roots. Experienced workers require 168 h to harvest 1 ha of flax manually. Because of high labor cost, harvesting is usually accomplished by cutting the plants with animal- or tractor-drawn reapers or mechanical pullers. However, the reapers waste fiber by cutting too high, and a pulling machine may scuff or crush the straw where the grip is applied. The fibers in the damaged sections may be weakened during retting. After harvesting, the plants are placed into shocks and left to dry.

Deseeding removes the seed bolls from the plants. In primitive systems, the seed bolls are removed by pulling the plant through an upright steel comb called a *ripple* (Fig. 9.45). A typical ripple consists of a row of iron spikes in² (3.2 cm²) in cross section and 18 in (45 cm) high with a 3/16-in (5-mm) clearance at the bottom. The top 3 in (7 cm) of the spike tapers to a point.²⁴ Ripple deseeding requires about 18-20 h/t of pulled flax.²⁵ When powered rolls are used for deseeding, the work is accomplished faster. The flax plants are fed through spring-loaded metal rolls, which crush the seed bolls. The flax seed falls onto a screening device, which cleans and collects it. After deseeding, the flax is rebundled into sheaves.

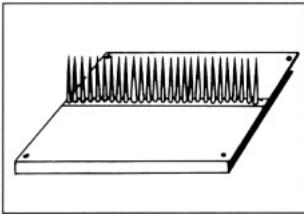

9.45. Ripple.

Retting is a fermentation process in which microorganisms loosen the bond between the fiber and the rest of the plant. Repeated exposure of flax to dew by spreading it on the ground is called *dew retting*. The immersion of sheaves of flax in water is called *water retting*. In unsophisticated systems, the flax is placed in ponds or streams. In systems with greater control, the flax is placed in large tanks, where the water temperature is maintained at 30-35 °C and retting is completed in 4-6 d.

After retting, the wet flax straw is spread in a field and dried in the sun. This is the fourth step in the preparation of linen cloth.

Scutching, the separation of the fibers from the rest of the plant, is the fifth step. During this operation, the dry, woody portion of the stem is crushed and broken by passing it through a series of fluted rollers. The straw is then held at one

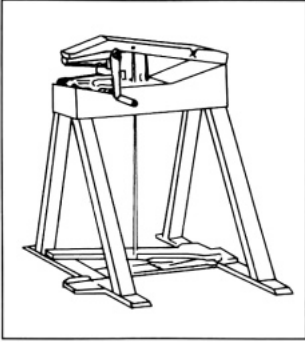

9.46. Decorticator.

end, and, by beating and scraping, the dry broken pieces of the stem are removed from the fibers (decorticated). A decorticator is shown in Figure 9.46.

Combing—also called *backling*—is the sixth and final step. The scutched fiber is drawn manually over a series of combs. This process removes short, tangled fiber: straightens the long fibers: and lays them in parallel strands. In mechanized operations, hackling is done during the last stage of the scutching process.

9.4.5 Coir. Coir is the fiber obtained from coconut husks. “White” coir is produced from green (unripe) coconuts by manually beating the fibers out from the husk. The fibers are then spun into yarn and made into mats and other household products. “Brown” coir is a by-product extracted from the husks of ripe coconuts harvested for copra, oil, or desiccated coconut, and is the coir usually referred to in commerce. Forty coconuts yield about 2.7 kg of coir.²⁶ The first step in preparing coir is to husk the coconut by ramming it onto a stationary spike and ripping the husk from the nut into three to five pieces. The husks are then retted for 1-6 mo in either fresh water or seawater to loosen the fibers from the rest of the husk. Powered steel crushing rolls are often used to crush the husk before retting to hasten the retting process.

After retting, the fiber is sun-dried and then decorticated. The dry husks are held with both hands against a powered roller containing a number of steel spikes called *needles*, which strip particles from the fiber. A foot-treadle machine can handle 3-5 kg of husk (10 pieces) per hour, while a 3-hp machine tended by three operators has a capacity of 200-250 kg, or 600 pieces per hour. An 8-hp engine-driven decorticator will decorticate nonretted husks at the rate of 2,000 complete husks in a 10-h day. The fibers from the decortivating machine must then be put through a carding machine before being made into rope, twine, or mattress stuffing.

9.4.6 Sisal. Sisal (*Agave sisalana*) is used primarily for agricultural baler twine. (Henequen [*Agave fourcroydes*] and maguey [*Agave cantala*] are also referred to as sisal for commercial purposes.) Sisal is grown for the fibers contained in the plant’s fleshy leaves. Sisal leaves are usually about 1.2 m long with a sharp spine at the end of each leaf. Each mature

leaf contains about 1,100 creamy white fibers. A sisal plant produces 2-3 leaves per month, or 200-250 leaves over its 7- to 12-yr lifespan. A sisal plant flowers once and then dies. When the plant is about to flower (pole), a shoot resembling a giant spear of asparagus arises from the center of the plant to a height of 5-6 m. A sisal plant from which no leaves are removed until poling will live about 4yr, but by regular cutting of a few leaves from a plant throughout the year, its lifespan is lengthened and its fiber productivity increased. The leaves are cut from the stem with a blade about 18 cm long and 3 cm wide; 16-18 leaves are left on the plant, except at the last cutting at poling, when all the leaves are removed.

Under primitive conditions, the fibers are extracted by beating the leaf to a pulp with a mallet. The fleshy particles are scraped away by drawing the fibers over the corner of a block of wood, and then washing them. Sophisticated decortication is accomplished by engine-powered machines such as a *raspador*, or automatic decorticator.

The raspador is a wheel 1 m in diameter and 30 cm wide, on the rim of which steel bars or knives are fastened. The wheel is mounted on a horizontal shaft and driven at a speed of about 500 rpm. The bottom of the wheel is set about 5-6 mm above a stationary base plate. The operator feeds a leaf into the space between the wheel and base plate. The direction of the rotation of the wheel tend to pull the leaf into the machine, but the operator holds onto the leaf and allows it to enter the machine at a uniform speed. Fleshy particles of the leaf fly from the rear of the machine. After the leaf is halfway into the machine, the operator removes it, grasps the exposed fibers, and decorticates the other half. One operator can decorticate 400-500 leaves per hour, although the work is tiring.

Automatic decorticators consist essentially of a shaft or drum to which beater knives are fastened. The leaves enter the automatic decorticator parallel to the axis of the drum. The flesh of the leaf is removed as it passes between the drum and a concave. The leaves are carried into the throat of the automatic decorticator by means of a conveyor. An automatic decorticator can process 25,000 leaves (10-20t) per hour.

During and after decortication, the fiber is washed with fresh water. The fiber is then dried, combed, and baled for shipment.

9.4.7 *Abaca*. *Abaca* (*Musa textilis*) is a member of the banana family and provides a fiber that is sometimes called Manila hemp. (The fiber is actually not hemp, but got its name from the port of Manila from whence it was first exported.) *Abaca* is a tropical plant requiring a hot and humid climate, heavy rainfall throughout the year, and well-drained soil. *Abaca* fiber is light buff and lustrous in color and the strongest of all the natural fibers.²⁷ In addition to its use in cloth and twine, it is superb for marine ropes because of its elasticity, strength, and resistance to salt water.

Abaca stalks can be harvested at about 4 yr of age, although the plant can live as long as 25 yr. New plantings are made after 10 yr of harvest, since maximum production falls off after about 8 yr. *Abaca* is harvested when blossoms appear on the flower stalks. Pseudostems at least 2.5 m (8 ft) long are cut off near the ground, and the leaf sheaths are stripped off. Each pseudostem has an outside layer that contains the commercial fiber, a middle layer with a few weak fibers, and an inner layer of soft tissue with no fibers. By inserting a machete between the outer and middle layers, ribbons of the outer layer 6-7 cm wide are stripped off for processing. The remainder is thrown away.

Manual processing consists of pulling the ribbons—called *tuxies*—between the knife edge of a machete and a hard wooden block. A smooth knife edge is used to produce fine fiber, while serrated blades are used to produce coarse fiber. A knife with large serrations requires little effort and wastes little material; a smooth or finely serrated knife leaves more waste and requires more work. An output of 10 kg of well-cleaned undried fiber per day by this method is considered good. The fiber is hung on lines and sun-dried after stripping.

An engine-driven spindle rotating at about 600 rpm can be used to pull the *tuxies* between the knife and the wooden block. The spindle is a cantilevered truncated cone about 15 cm diameter on one end, 10 cm on the other, and about 30 cm long. The conical spindle is whittled out of soft wood, since hardwood will not provide sufficient friction for the *tuxy*. The spindle is located between the operator and the knife/block assembly. The operator steps on a spring-loaded lever to open the space between the knife and the bottom plate, and inserts about half the length of a *tuxy* under the

knife. Removing his foot and allowing the tuxy to be caught between the knife and the block, he then wraps his end of the tuxy around the spindle, as a sailor would wrap a line around a capstan. The operator then pulls on the tuxy to create friction on the spindle, which pulls the tuxy between the knife and block. Since the spindle is conical, the tuxy is easily released by moving it axially toward the small end. The operator then flips the tuxy end over end and repeats the operation until the flesh is removed from the fibers.

Mechanization of abaca fiber production utilizes an engine-driven decorticator similar to the one used for sisal. When the decorticator is used, the outer sheath is not separated from the middle and inner sheaths, since the entire pseudostem is put through the decorticator. First, the stems are flattened by putting them through a pair of crushing rollers. Copious amounts of water are used by the decorticator for cleaning the fiber and washing away extraneous material. A decorticator produces cleaned fiber at the rate of about 0.5 t/h.

REFERENCES CITED

1. Philippine Council for Agriculture, Forestry and Natural Resources Research and Development (1977) *The Philippines recommends for rice*. Los Baños, Laguna, Philippines.
2. Agricultural Engineering Department (1982) *Operator's manual for CAAMS-IRRI 1.0 m reaper*. International Rice Research Institute, P.O. Box 933, Manila, Philippines.
3. Fernando M D, Palipane K B (1983) *A comparative study on buffalo, tractor, and mechanical threshing in Sri Lanka*. RPRDC Technical Report 14/83. Rice Processing Research and Development Center, Jayanthi Mawatha, Anuradhapura, Sri Lanka. p. 3-10.
4. *Ibid.*, p. 8.
5. Shimamoto T, Hiyaniuda S, Fujita S, Nozoe A, Yamaguchi, H, Kabushiki J (1969) *Harvester combine*. U.S. Patent 3,423,910. Assigned to Kubota, patented 28 Jan. 1969.
6. Anonymous (1986) *Rotary roundup*. Power Farming. p. U5. October 1986.
7. Prairie Agricultural Machinery Institute (1981) Report No. E3180D, John Deere 8820, self-propelled combine. Humboldt, Saskatchewan, Canada.
8. Prairie Agricultural Machinery Institute (1981) Report No. E3180B, Allis Chalmers Gleaner N-6 self-propelled combine. Humboldt, Saskatchewan, Canada.
9. Prairie Agricultural Machinery Institute (1981) Report No. E3180A, International Harvester 1480 self-propelled combine. Humboldt, Saskatchewan, Canada.

10. Sherma A P (1979) Studies on the mechanized harvesting of cassava in Fiji. *Agric. Mech. Asia* 10(2):39-41.
11. van der Sar T (1979) Hand-operated cassava harvesters. *Agric. Mech. Asia* 10(1):64-68
12. Kemp D C (1978) Harvesting: a field demonstration and evaluation of two machines. Pages 52-57 *in* Cassava harvesting and processing proceedings, CIAT, Cali, Colombia, 24-28 April, 1978. E.J. Weber, J.H. Cock, and A. Chouinard, eds. International Development Research Center. Ottawa, Canada.
13. Leihner D (1978) Follow up evaluation of two harvesting machines. Pages 58-59 *in* Cassava harvesting and processing proceedings, CIAT, Cali, Colombia, 24-28 April, 1978 Weber, E.J. et al, eds. International Research Development Research Centre, Ottawa, Canada.
14. Klinner W. E, Aspinwell J S (1963) Report on test of Busatis BM 315 KW rear-mounted double-knife mower. National Institute of Agricultural Engineering, Silsoe, England
15. Campbell J K (1971) An Investigation of tedding upon field drying of alfalfa. Agricultural Engineering Staff Report No. 71-1. Cornell University, Ithaca, New York
16. Prairie Agricultural Machinery Institute (1980) PAMI Evaluation Report E3179D. International 1190 mower-conditioner. Humboldt, Saskatchewan, Canada.
17. Koegel R G. Straub R J. Walgenbach R P (1984) Quantification of mechanical losses in forage harvesting. ASAE Paper 84-1524. American Society of Agricultural Engineers, St. Joseph, Michigan.
18. Blevins F Z, Hansen HJ (1956) Analysis of forage harvester design. *Agric. Eng.* 37(1):21-29.
19. Prairie Agricultural Machinery Institute (1979) New Holland Model 320 Baler, PAMI Evaluation Report E1978C. Humboldt. Saskatchewan. Canada.
20. Belyea R, Bell S, Martz F (1984) Large, round bales work well. but *Hoard's Dairyman*, August 25, 1984, p. 971.
21. Watson L J (1951) The effect of mechanical harvesting on quality. Pages 25-26 *in* Proceedings of the fifth annual cotton mechanization conference. National Cotton Council, Memphis, Tennessee.
22. Weindling L (1947) Long vegetable fibres. Columbia University Press, New York.
23. Mandal T C, Dutta R K, Ojha T P (1987) Principles of mechanical extraction of base fibre. *J. Agric. Eng.* 24(2):197-205.
24. Royle J F (1855) The fibrous plants of India. Smith, Elder & Company, London. p. 216.
25. Hammond J E (1951) Processing of fiber flax in Oregon. *Crops In Peace And War, The Yearbook Of Agriculture 1950-1951*; United States Department of Agriculture. U.S. Government Printing Office. Washington. D.C.
26. Royle, op. cit., p 102-103.
27. Kirby R H (1963) Vegetable fibres. Interscience Publishers, New York.

BIBLIOGRAPHY

- Avery P J (1963) Hay baling apparatus. U.S. Patent No. 3,110,145; 12 Nov. 1963.
- Barrington G P, Berge O L, Finner M F (1969) Effect of using a re-cutter in a cylinder cut forage harvester for chopping low moisture grass silage. ASAE Paper No. 69-145. American Society of Agricultural Engineers, St. Joseph, Michigan.
- Bolley H L, Marcy W L (1907) Flax culture. Farmers' Bulletin 274. United States Department of Agriculture, Washington. D.C.
- Campbell J K (1986) Reducing potato harvester bruising by adjusting apron speeds. Agricultural Engineering Idea Sheet 76. N. State College of Agriculture and Life Sciences. Cornell University, Ithaca, New York.
- Chuo , Boeki Goshi Kaisha (Central Commercial Company) (no date) CeCoCo guide book for rural cottage and small and medium scale industries. 7th ed. "CeCoCo" Exhibition Demonstration Center, Ibaraki City, Japan.
- Dewey L H (1914) Hemp. Pages 283-346 in 1913 yearbook of agriculture. United States Department of Agriculture. Washington, D.C.
- Hennen J J (1971) Power requirements for forage chopping. ASAE Paper No. 71-145. American Society of Agricultural Engineers, St. Joseph, Michigan.
- Kepner R A, Bainer R, Berger E L (1972) Principles of farm machinery. 2d ed. AVI Publishing Co., Westport. Connecticut.
- Quick G, Buchele W (1978) The grain harvesters. American Society of Agricultural Engineers, St. Joseph, Michigan.
- Schrock M D, Figurski D L, and McReynolds K L (1975) Hay handling systems. Report C-537. Kansas State University Extension Service, Manhattan, Kansas.
- Tracy S M (1903) Cassava. Farmers' Bulletin 167. United States Department of Agriculture, Washington, D.C.

10 Grain drying and storage

Grain drying and storage usually occur at a static location and are not normally included in a book primarily about mobile tools and field machinery. But the drying and storage of a crop are affected by its harvesting and transport, and the costs of growing and harvesting cannot be recovered until the crop is stored safely. This chapter deals primarily with the basic principles of drying and moving air through agricultural products.

10.1 Basic principles

A grain kernel appears inert, but it is actually a living organism consuming oxygen and carbohydrates. It produces carbon dioxide and heat. Fungi are always present, waiting to attack the grain and cause its deterioration. Between harvest and safe storage, farmer and fungi are engaged in a race to determine which will enjoy the grain as food.

Grain can be protected during storage and kept suitable for human consumption by any or all of these measures:

- drying the grain until fungi are inactive and grain respiration ceases,
- cooling the grain until fungi are inactive and grain respiration is nil,
- placing the grain in an environment with very little oxygen. and
- using a fungicide such as propionic acid to preserve the grain.

In storage, grain must be protected from rodent and insect infestation, deterioration by extremes of temperature and moisture, loss through mishandling, mixing with other lots of grain, and damage by microorganisms.

At harvest, grain and pulses usually contain too much moisture for safe year-round storage. Grain is often harvested before it is dry so that it cannot be threshed from the plant by the wind or eaten by birds and rats while still in the field. Also, harvest frequently occurs during the rainy season. Better quality grain can often be obtained if it is harvested before becoming fully dried on the stalk, and then artificially dried under controlled conditions.

Moisture content (MC), the most useful and reliable index of the keeping quality of cereals and pulses, is expressed in percent and is usually calculated on wet basis (wb):

$$\%MC = \frac{\text{weight of water in grain}}{\text{weight of water in grain} + \text{dry grain matter}} \times 100$$

Water molecules in air are in motion and exert a vapor pressure. The vapor pressure in grain is determined by the grain's characteristics, the amount of water in the grain, and the temperature of the grain. If the vapor pressure created by the water molecules in the grain is greater than the vapor pressure of water in the surrounding air, the crop loses moisture to the air until the vapor pressures equalize. When conditions are reversed, the crop absorbs moisture. A biological material such as grain or forage attains equilibrium moisture when, at the same temperature as the air, both the air and the biological material have the same water vapor pressures. When equilibrium moisture content exists, no moisture interchange occurs. A crop's equilibrium moisture content should not be confused with relative humidity (RH).

When is grain dry? In general, grain must be dried to a MC not greater than its equilibrium moisture at 70% RH and 27°C (80°F) for long-term storage. Table 10.1 lists equilibrium moisture values at 70% RH and about 25°C (77°F) for common grains and other agricultural products. This is the maximum acceptable level for long-term storage.

To dry grain, the vapor pressure of the moisture in the air surrounding the kernels must be less than the vapor pressure of the moisture in the grain. The most common means of lowering the air's vapor pressure is to heat the air. If the air temperature is increased while air moisture is constant, the vapor pressure drops. Decrease in vapor pressure is revealed by a decrease in RH. For example, if air at 27°C (80°F) and

Table 10.1. Equilibrium moisture content at 25 °C (77 °F) and 70% RH.¹

Commodity	Equilibrium moisture content (% wet basis)
Barley	13.5
Buckwheat	14.2
Cocoa bean	7.0 ^a
Copra	7.0 ^a
Cottonseed	10.1
Cowpea	15.0 ^a
Dry bean, red Mexican	15.2
Dry bean, flat small white	15.0
Dry bean, pinto	15.2
Flaxseed	9.3
Peanut, shelled	7.0 ^a
Maize, yellow dent shelled	14.0
Millet	16.0 ^a
Oat	13.0
Palm kernel	5.0 ^a
Rice, rough	13.2
Rice, polished	13.8
Rye	13.5
Sorghum	13.8
Soybean	11.5
Wheat, hard red winter	13.9
Wheat, white	13.7
Wheat, durum	13.1

^aAt approximately 27 °C (80 °F).

95% RH is heated to 38 °C (100 °F), RH drops to 50%; if heated to 60 °C (140 °F), RH drops to 17%.

When air is cooled and moisture is constant, RH increases until the dew point is reached, and water comes out of the air as dew or rain.

The amount of water that must be removed from wet grain can be calculated by the following equation:

$$\text{wt of H}_2\text{O to remove per wt of wet grain} = \text{wt of wet grain} \times \left[1 - \frac{100 - \text{MCWG}}{100 - \text{MCDG}} \right]$$

where wt = weight,
 WG = wet grain,
 DG = dry grain,
 MC = moisture content wb (%)

Example: How many kilograms of water must be removed from 1,000 kg 30% MC grain to dry it to 15% MC?

$$H_2O = 1,000 \times \left[1 - \frac{100 - 30}{100 - 15} \right]$$

$$H_2O = 1,000 \times \left[1 - \frac{70}{85} \right]$$

$$H_2O = 1,000 \times (1 - 0.824)$$

$$H_2O = 1,000 \times 0.176$$

$$H_2O = 176 \text{ kg to be removed}$$

Table 10.2 shows the maximum amount of water that can be absorbed by air at various temperatures because of changes in RH when air is heated. The initial condition of the air is 15.5°C and 65% RH. (The table assumes 100% efficiency. In actual practice, only 50-80% of the water will be removed per hour per 1,000 ft³/min [0.47 m³/sec] of air.)

The length of time grain may be stored without spoilage has an inverse relationship to temperature and moisture content. Although exact data are not available for many grains, the relationship is well documented for shelled maize. Shelled maize at 25% MC can be stored at 75°F (24°C) for only 4.3 d before deteriorating, but the same maize at 35°F (2°C) can be stored for 42 d before, there is significant deterioration to lower the grade.²

In climates where grain is harvested during the dry season, harvesting can be delayed while the grain dries to a moisture suitable for storage. In some areas, farmers break over maize

Table 10.2. Effect of heating upon water-holding capacity of air.

Air temperature		Air RH (%)	Water removed/h	
°F	°C		Per 1000 ft ³ /min (lb)	Per 100 m ³ /min (kg)
60	15.6 (unheated air)	65.0	7	11.3
70	21.1	45.0	12	19.1
80	26.7	32.0	18	29.0
100	37.8	18.0	31	49.8
140	60.0	5.8	60	96.4
180	71.1	2.2	78	125.0

ears on the stalk so that the ear remains attached, but cannot receive moisture from the stalk. Many crops such as rice, however, shatter badly if dried in the field. Moreover, the longer a crop is left in the field, the greater the loss due to wind, insects, and rodents.

Grain density and angle of repose must be considered during handling, drying, and storage. Wheat weighs nearly twice as much as oats, and a third more than rough rice. Thus, the floor of a grain dryer holding wheat must be twice as strong as a dryer holding oats. (In practice, dryers and bins are usually designed to support the densest grains.)

The angle of repose of filling can be determined by pouring grain onto a floor to form a conical pile. The angle between the floor and the tip of the cone is its angle of repose of filling. The angle of repose of emptying can be determined by opening one end of a bin of stored grain and allowing the grain to flow out until the mass of grain stops. The resultant angle between the surface of the grain and the floor is the angle of repose of emptying.

The angle of repose of filling is never greater than the angle of repose of emptying. A grain's density and angle of repose interact to exert pressure on the bin walls. The term *equivalent fluid weight* takes into account the angle of repose as well as density, and is used to estimate the force on side walls of a grain bin. For example, a bin filled with rough rice to the height of 2 m has a mass of 1158 kg on each square meter of the floor ($2 \text{ m} \times \text{density of } 578.96 \text{ kg/m}^3 = 1,158 \text{ kg/m}^2$) and a pressure of 5.56 kPa at the base of the walls ($2 \text{ m} \times 283.5 \text{ kg/m}^3 \text{ fluid density} \times 9.80 \text{ kgf per newton} = 5.56 \text{ kPa}$).

The information given in Table 10.3 is for dry grains used in commodity trading. Grains with higher moisture usually have higher angles of repose for both filling and emptying, as well as higher density.

10.2 Cribs

A crib is a specialized storage structure designed both to hold grain and to enhance the drying process. Cribs are used primarily for drying cob maize (ear maize). Because of the spaces between the ears, the interchange of air and moisture is facilitated better than if the crib were filled with shelled maize. Cribs perform best in temperate regions, where storage of undried grain corresponds to the onset of cooler weather. Figure 10.1 illustrates a typical maize (corn) crib.

Table 10.3. Density and slope characteristics of dry grains.

Product	Unit weight		Angle of repose		Equivalent fluid weight	
	lb/ft ³	kg/m ³	Filling	Emptying	lb/ft ³	kg/m ³
Barley	38.55	617.57	16°	28°	21.9	350.8
Buckwheat	40.16	643.36	30°	30°	13.4	214.7
Maize, shelled	44.98	720.58	16°	27°	25.5	408.5
Oat	25.7	411.71	18°	32°	13.6	217.9
Rice, rough	36.14	578.96	20°	36°	17.7	283.5
Rye	44.98	720.58	26°	26 ^{°a}	17.6	282.0
Sorghum, grain	44.98	720.58	20°	33°	22.1	354.0
Soybean	48.19	772.00	16°	29°	27.4	438.9
Wheat, soft winter	48.19	772.00	16°	27°	27.4	438.9

^a Estimated.

Maize cribs should be constructed and oriented to take advantage of the prevailing wind. Cribs in humid areas must be narrow.

In the northeastern USA, unhusked maize can be safely stored and dried in 1.4-m-wide (4 1/2-ft) cribs at 40% whole ear MC (35% kernel MC).³ In this region, ear maize is harvested and stored during October and November. The drying process is fastest early in the storage period, decreases to a minimum during the cold winter months, and accelerates to completion during the warmer days of March and April.

10.1. Small North American maize crib that holds 15 t dry ear maize.

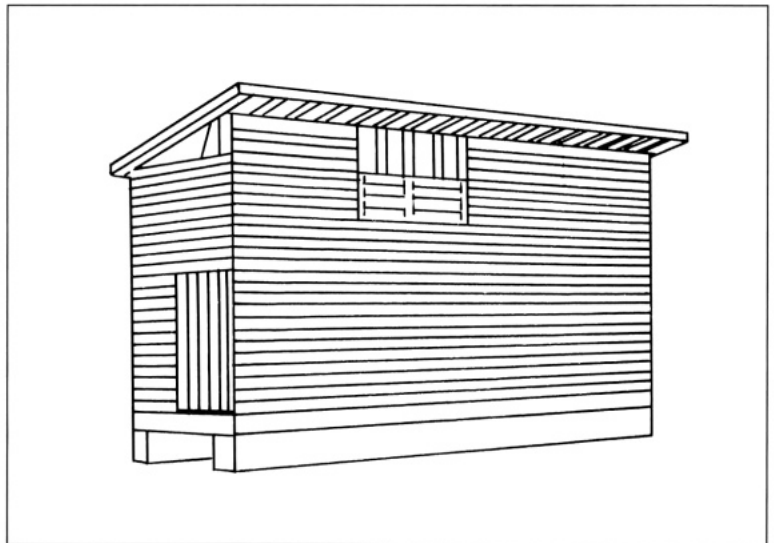

Cob maize shrinks as it dries. Three volumes of wet cob maize shrink to 2 1/2 volumes of dry cob maize, which in turn produce 1 1/4 volumes of dry shelled maize.

Husks are usually removed before cribbing to ensure quicker drying. Where maize with tight-fitting husks is grown and pesticides are not used during storage, unhusked maize should be stored, since the husks provide a mechanical barrier to moths and insects.

Tobacco barns are essentially large cribs. Their sides are large doors that can be opened to provide air movement during good drying weather. During wet weather, the doors are closed. The tobacco leaves are hung from poles spaced for adequate air movement.

10.3 Drying with heat

Drying with heat does not eliminate the need for air movement. In fact, the heating of moist grain to hasten the drying process is of no avail unless air moves through the grain and carries away the water molecules.

Shallow layer solar drying is the most elementary drying system. The grain is spread to dry in a thin layer on a flat area exposed to sunlight: packed earth, concrete, matting, or plastic sheet (Fig. 10.2). The surface of the drying area should

10.2. Shallow layer solar drying and types of drying in the Philippines.

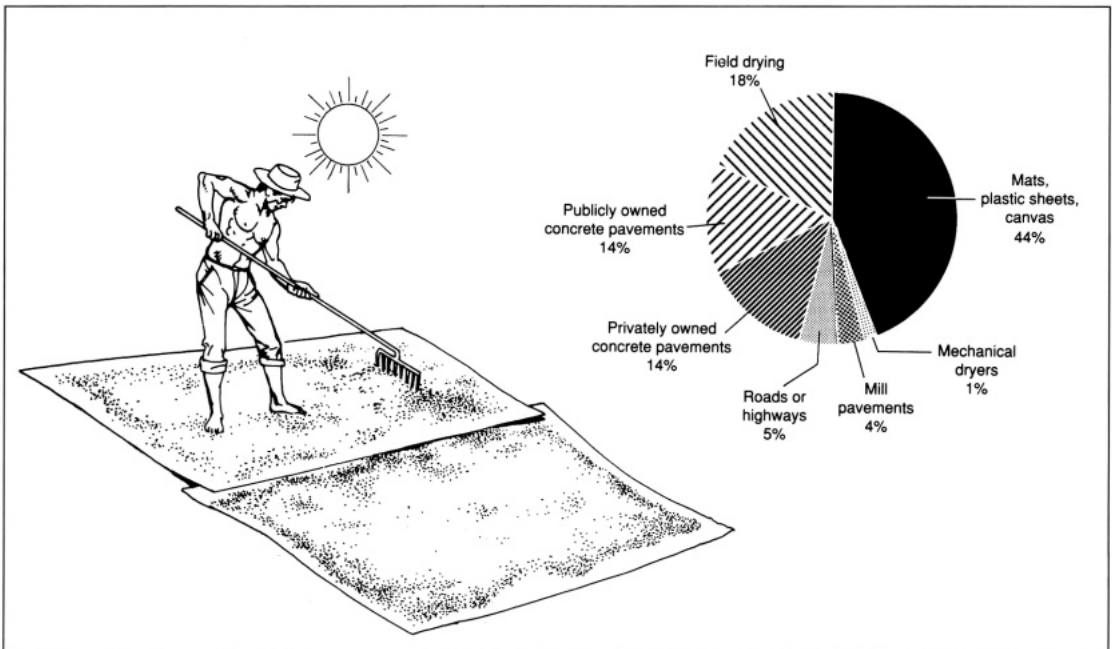

prevent the movement of soil moisture from the drying floor to the grain. The optimum thickness for sun-drying rough rice is 2-4 cm.

Grain should be turned during drying to ensure even drying and to prevent overdrying of the grain on top. A wooden rake, scraper, or plow is pushed through the grain to mix it. Care must be taken to prevent foreign material such as pebbles and soil from mixing with the grain, as some kernels may be broken. Sun-drying is advantageous in that it does not require purchased equipment, except perhaps a plastic sheet. In many regions in Asia, edges of paved highways or concrete plazas are utilized to sun-dry rice and other grains. Since sun-dried grain is exposed, provision must be made to cover it or to shovel it into containers when rain is imminent.

An investigation of rice production in the Philippines revealed that conventional solar drying on pavements or hard earth resulted in significantly lower head rice recovery than mechanical drying.⁴ Head rice recovery is the percentage by weight of unbroken kernels of milled rice. Total rice recovery, which includes both broken and whole grains from the rice mill, was only marginally lower than that of mechanically dried rough rice. The recovery rate is affected by both the type of mill in which the rough rice is processed and the drying method.

Sun-drying research on rough rice revealed that

- if the rice is mixed at half-hour intervals, there is no significant difference in uniformity of moisture distribution throughout grain depths of 1, 2, 4, and 6 cm;
- when the rice is mixed at intervals of 2 h or longer, or not mixed at all, grain depth should be 1-2 cm;
- total milling recovery is unaffected by 1-6 cm rice thickness if mixing occurs at half-hour intervals;
- head rice recovery and the degree of uniformity of rice MC are directly related.⁵

The passive solar dryer (Fig. 10.3) is a glass-covered box containing a perforated tray that supports the produce. This type of unit is more often used for drying fruit and vegetable slices than grain. Its primary advantage is that the glass (or transparent plastic cover) protects the produce from dust, insects, and rain. Its secondary advantage is that its design provides a natural draft that removes saturated air from the

10.3. Passive solar dryer.

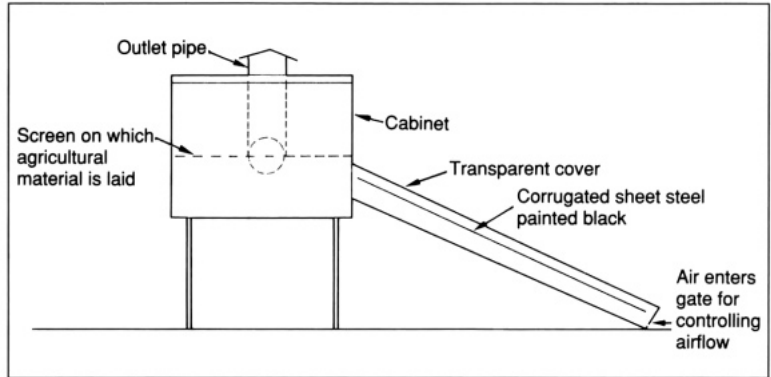

dryer. A typical solar dner has 3 drying area of about 1.25 m^2 . Its framework is nude of wood and hardboard sheets; wood shavings and excelsior are used for insulation. Two sheets of mylar polyester film 0.13 mm (5 mil) thick and spaced 2 cm apart are used for the transparent cover. The angle of the transparent cover is determined by the latitude where it is used. The angle of the absorber to the horizontal should approximate the degree of latitude. Air flows upward by natural convection through holes at the base of the cabinet. It then circulates around the produce, which is placed on a wire tray positioned several centimeters above the cabinet floor. The air is then exhausted through holes along the upper sides and rear of the cahinet.

The oil-barrel dryer (Fig. 10.4) burns fuel to provide heat without using a mechanically driven fan to force air through the grain. Its name is derived from an early design that used oil barrels as a source of construction material.⁶ The grain must be spread in a thin layer, since little airflow through it is possible. The temperature of the grain should not be greater than $50\text{-}55 \text{ }^\circ\text{C}$ ($120\text{-}130 \text{ }^\circ\text{F}$). Wood, coconut husk, straw, or other biomass is generally used for fuel. Oil-barrel dryers are usually wasteful of fuel, and grain temperature is difficult to control.

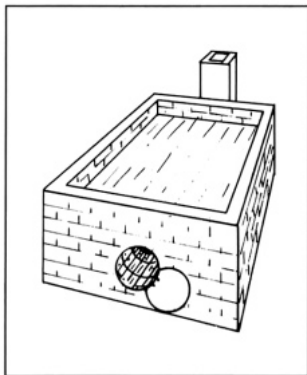

10.4. Oil-barrel dryer.

The conduction-type continuous-flow drum dryer is an improvement of the oil-barrel dryer. In some areas where rice is sun-dried, a serious problem exists during the monsoon, when it may rain constantly for a week or two. The conduction-type continuous-flow drum dryer is designed to complement sun-drying. Rough rice harvested at 27% MC (wb) will heat and spoil in a few days unless it is dried.

Continuous-flow drum dryers such as the IRRI predryer (Fig. 10.5) can dry rough rice to 18-20% MC.⁷ The rice can subsequently be held for up to 2 wk without deteriorating. It can then be sun-dried from 18% MC to its storage level of 14% MC.

The conduction-type continuous-flow drum dryer shown in Figure 10.5 uses biomass such as coconut husk, straw, or wood as fuel. Average fuel consumption is about 1 kg coconut husk per kg moisture evaporated, or approximately 16.9 MJ gross energy per kg moisture evaporated (7260 BTU/lb moisture).

The powered conduction-type drum dryer utilizes biomass such as charcoal, rice husk, or coconut husk as the heat source. The drying cylinder is about 35 cm in diameter and 120 cm long. It is surrounded by an insulating cover made from rice straw and mud plaster. The mud-straw plaster requires replacement after about 4 mo of use.

For drying rice, the drum temperature should not exceed 250°C (480°F), for puffing occurs when the rice approaches

10.5. Conduction-type continuous-flow drum dryer.

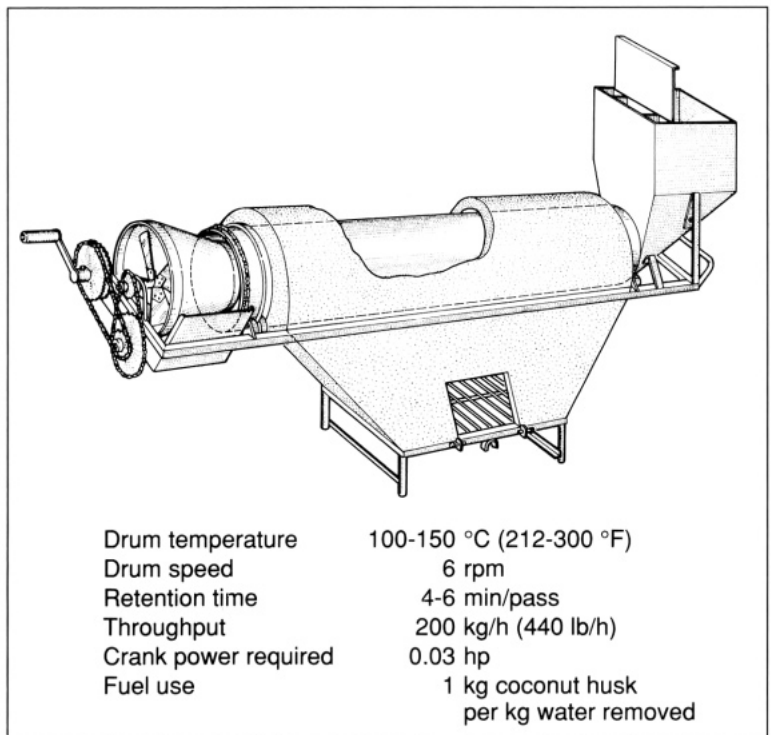

100°C (conduction dryer drum temperature 250°C). Rice yellows when subjected to higher temperatures, with a subsequent loss in commercial value. The dryer can reduce grain moisture by 1-2% when initial moisture is below 24%, and by 3-5% when initial moisture is above 24%. Two passes through the dryer with a cooling interval of one to several hours reduces moisture content to 18-20%. The grain can then be held until it can be sun-dried to its storage moisture content of 14%. Higher head rice recovery is usually obtained with a conduction-type of drum dryer than with 100% sun-drying, but the degree of whiteness of the milled rice may be lower.

The direct burning of biomass is satisfactory for small conduction dryers, but for larger units it is usually better to convert the biomass into gas first and then burn the gas in the dryer. Although the system requires the purchase of a gasifier, better control of drying temperature is possible, and gas is a clean-burning fuel.⁸

In some parts of India, wet grain is dried by mixing it with hot sand. Heat transfer to the rice is rapid because of the intimate contact and the great mass of sand. The rice is slightly parboiled, with gelatinization occurring in the outer layer of the kernel. A continuous-flow, heated-sand rotary dryer built at IRRI constantly heated the sand to 150-180°C (300-350°F); introduced wet grain into the hot sand at the ratio of about 1 to 20 by weight; screened the dried rice from the sand; and returned the sand to be reheated. The dryer was able to reduce moisture by 20% in 15-30 sec. The thermal efficiency was between 30 and 40%—high speed demanding more energy. Tests showed that heated-sand drying of rough rice above 20% MC (wb) increased head rice yield, but drying of rough rice below 20% MC at a sand temperature above 118°C (245°F) decreased head rice yield.⁹

10.4 Drying with forced air

Since airflow is useful for absorbing moisture from grain and transporting it away from the grain, all common drying systems utilize it. The sun-drying method uses natural airflow above the grain, while the conduction-type drum dryer uses air contacting the grain as it cools between passes. It is possible to hasten drying by constructing a building with a tall chimney to create an air draft. High-value crops such as hops are sometimes dried in such buildings. Airflow is not controlled by an operator in these drying methods.

Wind is undependable and varies in strength. To obtain more control over drying, fans driven by electric motors or internal combustion engines are used for nearly all mechanical drying systems. (The exception is the conduction-type continuous-flow drum dryer.) The most important part of a mechanical dryer is a fan to provide airflow through the grain.

To dry grain satisfactorily in a mechanical dryer, minimum airflow rates must be observed to prevent spoilage. Table 10.4 lists recommendations for drying some common grains.

10.5 Resistance of grain to airflow

Grains and seeds resist the movement of air. Rough rice offers twice the resistance of shelled maize. Resistance to airflow depends on the shape and size of the grain, the amount of trash in the grain, the depth of grain, and the airflow per unit volume of grain. Airflow resistance is measured as a pressure drop in inches or centimeters of water.

Pressure drop for specific grains is plotted on Shedd's Chart (named for C.K. Shedd, who devised it), shown as Figure 10.6. The total resistance of grain and ductwork to airflow is called static pressure (SP). Figure 10.6 refers to clean

Table 10.4. Recommendations for batch-drying of grain.¹⁰

Parameter	Ear maize	Shelled maize	Wheat	Rice (rough)	Barley	Sorghum	Soybean
Maximum grain moisture (%) for drying with							
Ambient air	30	25	20	25	20	20	20
Heated air	35	35	25	25	25	25	25
Maximum grain moisture for safe storage (%)	13	13	13	12	13	12	11
Maximum grain temperature (°C) ^a when used for							
Seed	43	43	43	43	40	43	43
Commercial use	55	55	60	43	40	60	50
Animal feed	83	83	83	-	83	83	-
Minimum airflow (air volume per volume of grain) ^b of unheated air for drying grain at a moisture content of							
30 %	1.5	-	-	-	-	-	-
25 %	1.5	4	-	3.25	-	-	-
20 %	1.5	2.5	2.5	2.5	2.5	3.25	3.25
16 %	-	1.5	0.75	0.75	0.75	1.5	1.5

^a40 °C = 104 °F, 83 °C = 180 °F. ^b Cubic meters of air per minute/cubic meter of grain or CFM per cubic foot of grain.

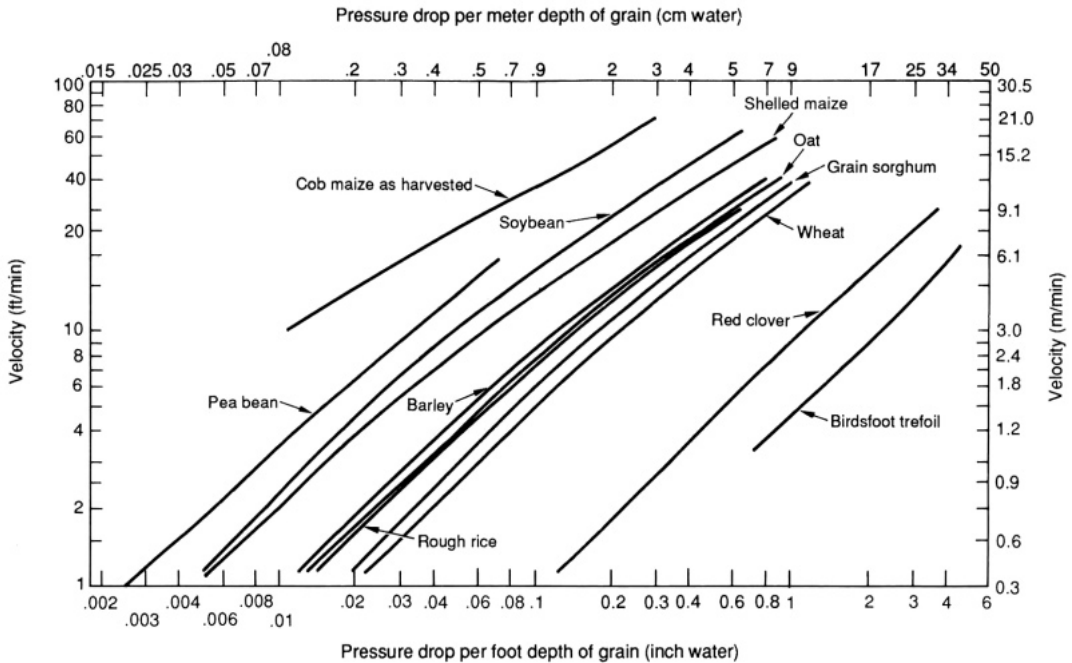

10.6. Shedd's Chart of resistance of grains to airflow.

grain. The chart's curves of airflow versus pressure drop are roughly parallel for the various grains and seeds plotted. For example, barley and rough rice offer more resistance to airflow than shelled maize, while soybean offers less. Broken kernels and fines (small particles of grain) increase resistance.

The ratio of the pressure drop for grain with fines to that of clean grain at the same airflow rate is called the pack factor. US Grade No. 2 shelled corn (maize) with maximum broken kernels and foreign material (3% by weight) has a pack factor of 1.2.¹¹ A poor grade of maize such as No. 7, with about 10% fines, can have a pack factor of 2.3, which means that the resistance to airflow, is the same as that of clean rough rice. The concept of pack factor and the fact that the airflow versus pressure drop curves are roughly parallel can be combined so that all agricultural seeds can be compared with clean shelled maize. Wheat has a factor of 3.48, while ear maize and baled hay have factors of 0.22.

The effect of resistance to airflow is illustrated in Table 10.5. It is assumed that a 7 1/2-hp fan is used to move air through the perforated floor of a 7-m diameter bin dryer containing shelled maize.

Table 10.5. Effect of fines on airflow through shelled maize.

Parameter	Clean shelled maize	Pack factor of 1.2	Pack factor of 2.3
Height of grain (ft)	3.5	3.4	3.0
Fan airflow (cfm)	12,260	11,900	10,500
Airflow (cfm/ft ³ grain)	10	10	10
Air velocity (ft/min)	35.6	34.4	29.8
Static pressure (in of water)	1.56	1.71	2.32
Press drop/ft depth (in of water)	0.44	0.50	0.78

In each case, the fan is working at a rate demanding 7 1/2 hp and is delivering 10 volumes of air per minute per volume of grain. In the case of maize, however, with 3% fines (pack factor 1.2), the height of grain must be reduced by 0.1 ft (3 cm) to keep the airflow per unit volume of grain constant. The grain with the pack factor of 2.3 had to be reduced by 14% in height to keep the airflow per unit volume of grain constant.

10.6 Fan characteristics

Various types of fans are used for drying crops. A fan delivering sufficient airflow against a 1-in SP may be unable to move any air against a 4-in SP. Fans are classed by airflow (in cfm) at the SP (inches of water column [IWC]) created by the resistance of the air duct and the grain. To design a drying system, it is insufficient to cite only the fan's diameter and hp. A fan curve that plots airflow vs SP is also required.

Table 10.6 lists the performance data of two 7 1/2-hp fans used for crop drying. If a fan is needed to dry a crop such as cob maize with little resistance to airflow, fan A should be used, because it produces greater air volume at low SP. To dry a crop with higher resistance to airflow such as rough rice, fan C should be selected. Note that fan C moves over 10 times as much air against a SP of 6 IWC as does fan A.

The two major fan types for drying agricultural products are the propeller fan and the centrifugal fan. The propeller fan is usually less expensive and provides a large volume of air against low SP. The centrifugal fan, on the other hand, provides a large volume of air against high SP. The propeller fan is noisier than a centrifugal fan of the same horsepower. The propeller fan is generally used when the SP is below 3 IWC. The centrifugal fan is designed to operate above 3 IWC. Fan A (Table 10.6) is a propeller fan, while fan C is centrifugal.

Table 10.6. Typical fan performance data for two 7 1/2-hp fans.

Static pressure (in of water)	Airflow (cfm)	
	Fan A	Fan C
0.5	14,250	10,350
1.0	13,400	10,080
1.5	12,500	9,820
2.0	11,500	9,550
2.5	10,400	9,330
3.0	9,000	8,980
3.5	7,500	8,700
4.0	6,200	8,350
4.5	4,450	8,000
5.0	2,250	7,620
5.5	1,350	7,230
6.0	650	6,750
6.5	-	6,250

Occasionally, more than one fan blows air into a common plenum chamber. A fan performance chart can determine the total airflow by summarizing the flow of each fan at a common SP value. For example, if fans A and C in Table 10.6 blow air into a common plenum, the resultant airflow, at 0.5 IWC SP is $14,250 + 10,350$ cfm, or 24,600 cfm. At 3.0 IWC SP, the airflow is $9,000 + 8,980$ cfm, or 17,980 cfm. At 6.5 IWC SP, it is $0 + 6,250$ cfm, or 6,250 cfm. In the last case, although both motors are running, no more air is delivered than by fan C alone. since fan A cannot move air against a SP of 6.5 IWC.

A grain dryer can use ambient air as the drying medium; but for faster drying, heat is frequently used (refer to Table 10.2). Moisture content differences in grain between nondry and dry states are called points of moisture in the USA. If grain is dried from 19 to 14% MC, 5 points of moisture are removed.

10.7 Combined forced-air and heat drying systems

Most grain dryers using solar heat or clean fuels such as electricity, natural gas, or propane to heat the air are direct-fired. All products of combustion pass through the grain being dried. Burners using wood, biomass, coal, or oils are indirect-fired, because the products of combustion do not pass through the grain. Indirect-fired units do not contaminate the grain but are more expensive than direct-fired units. There are four basic forced-air drying methods, any one of which can be the best choice depending on the specific conditions.

- Drying in storage
 - Sack
 - Low temperature
 - Layer
- Batch dryers
 - Batch-in-bin
 - Small flatbed
 - Recirculating batch
- Continuous-flow dryers
 - Nonmixing
 - Mixing
 - Continuous flow in bin
- Combination dryers
 - Dryeration
 - Combination

Drying in storage is a method in which the grain is placed in the storage container (a crib, for example) before being dried. Fans are utilized to move the air, and heaters to warm it.

A sack dryer is a system in which porous sacks such as burlap containing grain are piled to form a tunnel. Air (ambient temperature or heated) is blown through the tunnel, thereby drying the grain. Another sack dryer method makes use of a perforated floor, with each sack placed over an air duct. Sack dryers are more labor intensive than most forced air systems. However, the method is suitable if grain is stored in sacks and the amount is not large. Research stations often use this method for drying small quantities of grain.

The element common to low temperature, layer, and batch-in-bin drying system, is the circular steel grain bin with a perforated floor. Air is blown up through the grain by a fan and exhausted at the top of the bin. A heater placed in line with the fan can heat the air before it goes through the grain. The grain is not moved or circulated during the drying process. Air outlets must be open when drying grain in a storage bin. If the outlets are closed, the inadequate airflow increases SP, and the moistened air is not exhausted as rapidly as desired. Figure 10.7 shows a typical grain bin.

Drying with unheated air is much slower than drying with heated air. For example, air heated to 60°C will absorb 8 times the amount of moisture as air at 15°C. Unheated air drying is satisfactory for small quantities of grain under 25% MC,

10.7. Grain bin used for drying.

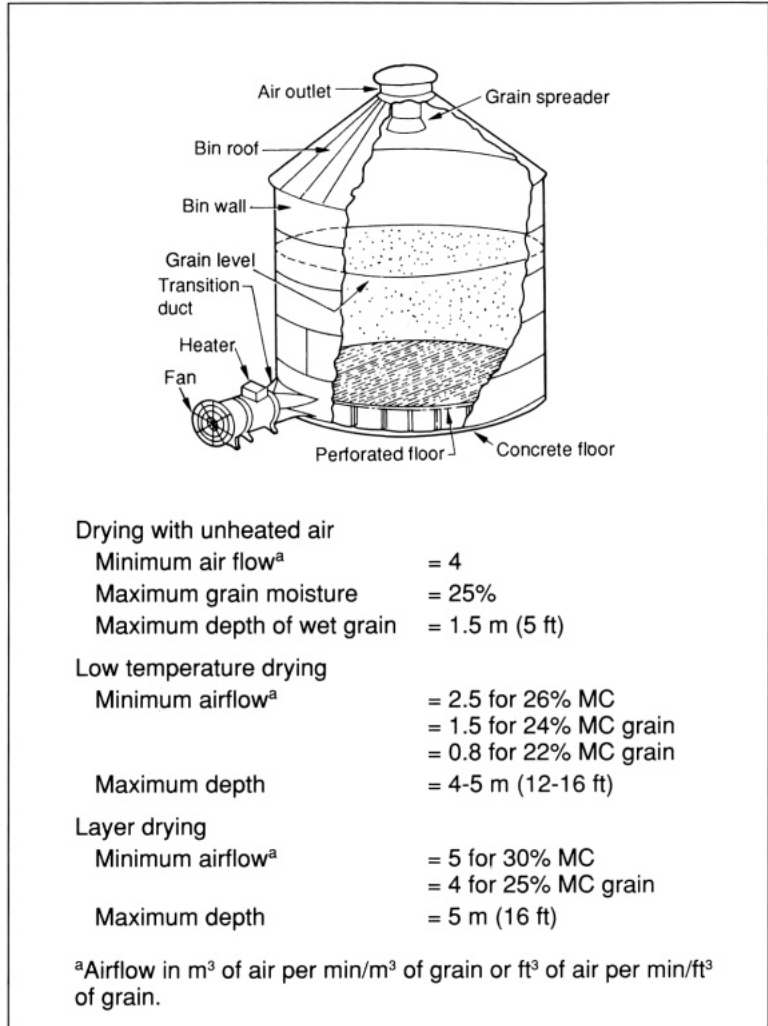

although continuous fan operation for up to 1 mo may be required to dry the grain to a safe storage level.

Dryers should be operated continuously until the grain is dried. During damp weather, some farmers turn the fan off to avoid rewetting the grain. This is a mistake. While it is true that some of the grain at the bottom of the bin may absorb a little moisture, grain continues to dry, and the moving air keeps it cool. Shutting off a fan during drying invites mold and spoilage.

Low temperature drying is sometimes practiced in the temperate zone when the temperature is between 0 and 10 °C.

The air is heated to increase air temperature about 5 °C, the burner is controlled by a humidistat, and the fan operates continuously. This drying method is used to keep fuel consumption down.

In the layer drying method, the bin is lined with successive layers of wet grain as each preceding layer dries. For example, when drying rough rice in a 5.5-m-diameter bin, 5 m deep, using a 7 1/2-hp fan, and when drying air temperature is 35 °C and MC is 28%, the following procedure could be used:

First fill	Second fill	Third fill
2.1 m (7ft)	1.9 m (6ft)	1.0 m (3ft)

When the top of the first layer has dried to 17% MC, the next layer is added. Approximately 3 1/2 d are required for a layer to dry to 17% MC. Note that each successive layer is less deep, since the increasing depth of grain means that less air is available. Drying speed depends on airflow per unit volume of grain when the drying air temperature and grain moisture remain unchanged. The drying air temperature in layer drying systems is frequently limited to a 10 °C (18 °F) increase over ambient temperature.

The dryer is only one element of a drying system. Many farmers experience difficulty not with their dryers, but with obtaining smooth movement of wet grain from field to dryer to storage.

The bin dryer used in the batch-in-bin system is usually constructed so that one day's harvest can be placed in a layer about 0.6-1.2 m deep; and then be dried, cooled, and transferred to storage within 24 h. Drying temperature is 50-75 °C (120-170 °F) while airflow is 12-50 volumes of air per minute per volume of grain. One batch takes up to 20 h to dry. A stirring device should be used for air temperatures greater than 60 °C (140 °F). At the end of the harvest season, the dryer is usually operated as a layer-dryer system or a low-temperature dryer system to fill the bin for grain storage.

The small flatbed dryer consists of fan, heat source, controls, and bin. The bin has a perforated bed, which is flat or inclined to facilitate unloading. It holds 1-2 t of grain up to 0.5 m deep, depending on the crop being dried. The space between the perforated bed, the walls, and the floor serves as a plenum to diffuse the air uniformly throughout the grain. An essential control is a fan switch to cut off fuel to the burner

should the fan stop. Some dryers are also equipped with a thermostatic control to automatically control temperature, and a humidistat to adjust air temperature to grain moisture.

The small flatbed dryer (Fig. 10.8) can be constructed with simple tools. The fan, however, must be designed and constructed with care to obtain the desired airflow/SP characteristics. Using a truck fan or a fan from a junkyard will not do a satisfactory job and will be wasteful of energy.

In a batch dryer, if the air temperature is high and the layer is thick, the grain at the bottom may be seriously overdried by the time the grain at the top is dried to the moisture content required for storage. Table 10.7 cites the results of drying rough rice 43 cm deep in a flatbed dryer using various air temperatures.¹²

The rough rice dried at the higher temperature exhibited greater breakage during hulling than did that dried at the lower temperature.

The drying procedure is the same for flatbed dryers and batch-in-bin dryers. The bin used for a batch-in-bin opera-

10.8. Flatbed dryer showing fan, burner, and bin.

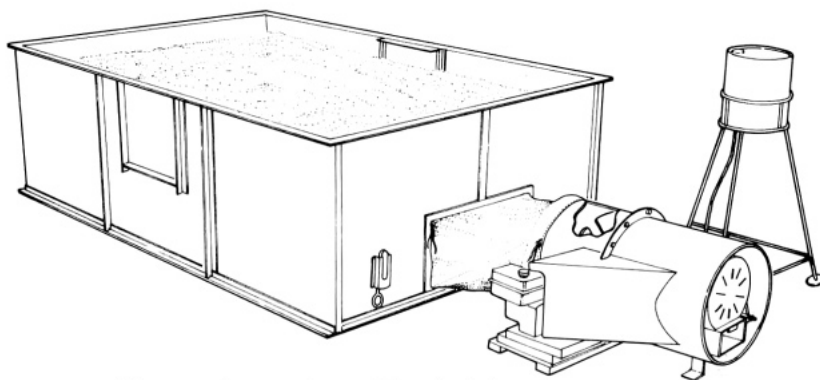

Power	3-hp gasoline engine or 2-hp electric motor
Fan	47-cm-diameter vane-axial
Heater	kerosene burner or rice hull furnace
Bin	275 x 190 x 100 cm
Grain depth	30-50 cm
Drying rate	For 30 cm depth of grain, 43 °C air temperature, and airflow of approximately 1800 cfm at 0.8 in of water, rough rice dries from 22 to 14% MC in 4 h.
Fuel consumption	0.75 liter gasoline/h, 2.0 liter kerosene/h, or 3-4 kg rice hull/h (1 t rough rice contains approximately 200 kg of hulls, sufficient to dry 1 t rough rice)

Table 10.7. Effect of air temperature on drying rough rice in a flatbed dryer.

Parameter	49°C (120°F)	60°C (140°F)	71°C (160°F)
Initial moisture content (% wb)	21.3	22.0	21.7
Drying time (h)	4.3	4.0	3.2
Rough rice moisture at top (% wb)	13.0	13.6	14.4
Rough rice moisture at center (% wb)	13.0	13.8	14.4
Rough rice moisture at bottom (% wb)	9.0	6.3	6.2
Average rough rice moisture of bin (% wb)	11.2	10.1	10.3

tion, however, is circular, with a roof that can be used for grain storage. Flatbed dryers cannot be closed and used for grain storage, since they have no roofs.

Recirculating batch dryers are cylindrical or cubical in shape, as shown in Figure 10.9. They hold 12-20 t of grain per batch. When the dryer is loaded with a batch of wet grain, it automatically circulates the grain through the drying zone. The dryer moves the grain so that grain temperature does not exceed about 60°C, although air temperature may be 65-120°C (150-250°F). The airflow is 30-85 volumes of air per minute per unit volume of grain.

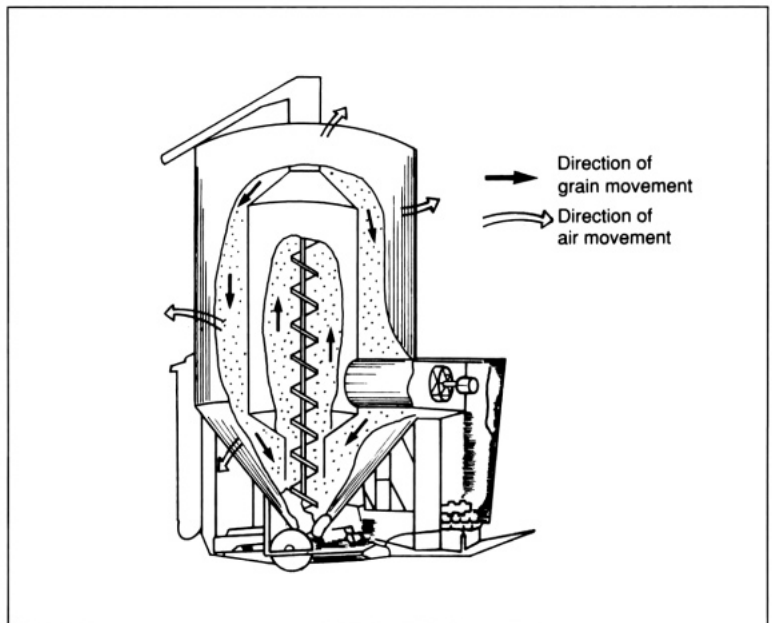
10.9. Recirculating batch dryer.

Removing 10 points of moisture requires 2 h of drying plus another 30-45 min to cool the grain before removing it from the dryer for storage.

Continuous-flow dryers are forced-air dryers designed to continuously receive wet grain and discharge dry grain. In nonmixing continuous-flow dryers (Fig. 10.10), wet and dry grain do not mix, while in mixing-type continuous-flow dryers, they are mixed during the drying process. The integration of wet and dry grain handling equipment associated with different dryers is important, but in the case of continuous-flow dryers it is essential. Storage bins for arriving wet grain must be available, and the dry grain must be moved into storage as soon as it flows from the dryer. Continuous-flow dryers use air temperatures up to 120 °C and airflows of 40 to more than 80 volumes of air per minute per volume of grain.

Nonmixing continuous-flow dryers that dry grain in thin vertical columns in one pass are quite common (Fig. 10.10). Wet grain enters at the top of the dryer and is cooled toward the bottom. Adjustable speed discharge rolls control the length of time the grain is exposed to the drying air.

A typical North American unit 2.5 m (8 ft) wide x 8.5 m (28 ft) long x 4.5 m (15 ft) high weighs 5 t. The grain layer thickness is 30 cm (12 in), and the burner can consume 120

10.10. Nonmixing continuous-flow dryer.

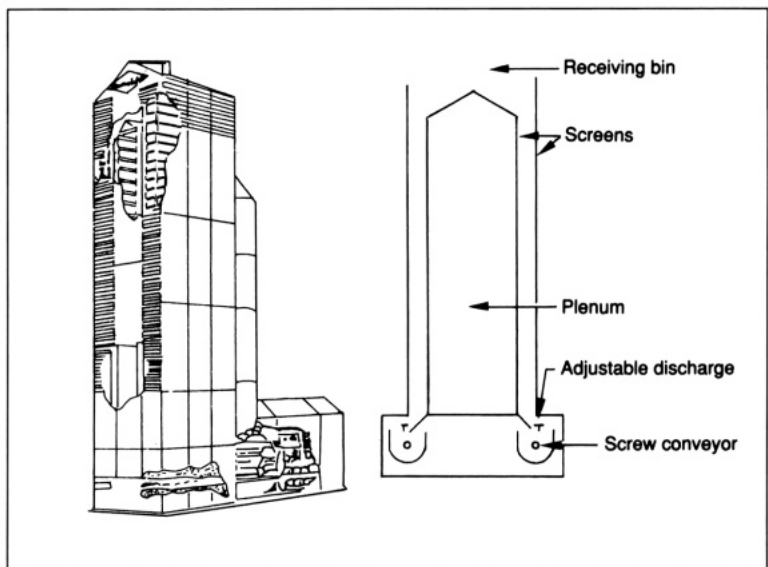

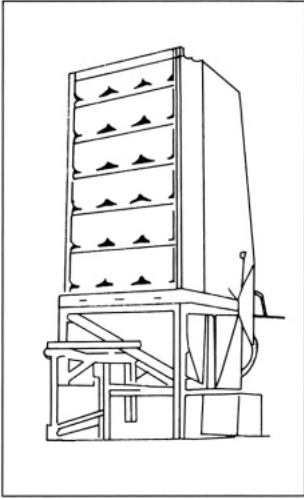

10.11. Mixing continuous-flow dryer.

liters (32 gal) of liquefied petroleum gas (LPG) per hour. Fifty horsepower is required to drive the two 91-cm-diameter (36-in) axial fans. Airflow through the grain is normally 80 or more volumes of air per minute per volume of grain. Drying air temperature is between 60° and 120°C (140-250°F).

Using 80°C (175°F) airflow, the dryer will remove 5 points of moisture per hour from shelled maize. Continuous-flow dryers are designed to remove grain moisture rapidly. They therefore require higher engine power to drive the fans and more fuel to heat the air.

Mixing continuous-flow dryers (Fig. 10.11) are similar to the vertical nonmixing dryers in that the wet grain enters on top and the dry grain exits at the bottom. Some dryers feature stationary baffles that tumble the grain as it flows down the vertical columns.

The Louisiana State University (LSU) dryer is a mixing continuous-flow dryer that mixes the grain as it moves downward past alternately spaced hot air inlets and moisture-laden outlets. The inlets and outlets are shaped like inverted Vs, and the rows are staggered so that the grain mixes as it tumbles downward (Fig. 10.12). Chaff and fines are blown out the outlets. Grain flow and moisture removal are controlled by the speed of grain removal from the bottom of the dryer. Some grains can be dried in a single pass through the LSU dryer. Grains such as rough rice, however, are passed once

10.12. Flow pattern in the LSU mixing-type dryer.

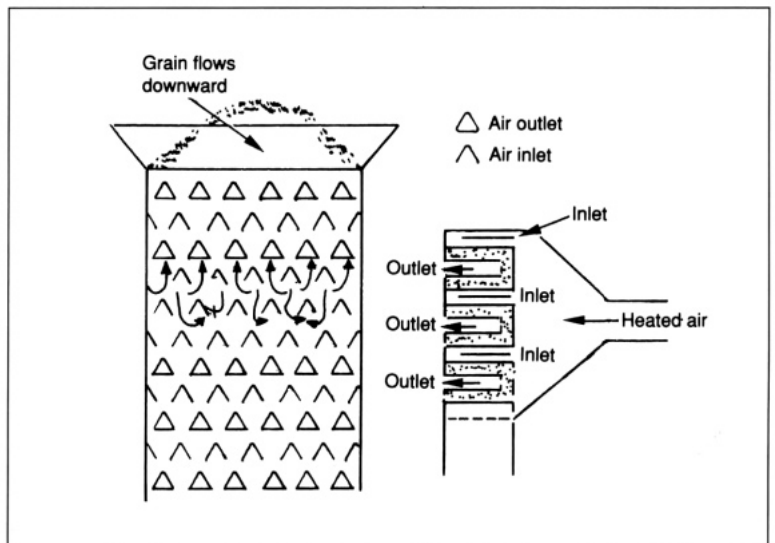

through the dryer to remove about five points of moisture. The grain is then tempered (steeped) in a bin, which causes the moisture in the kernel to flow from the center toward the exterior layer of the kernel. The grain is then passed through the dryer again, and the cycle is repeated until the grain is dried.

High-speed dryers often utilize a drying cycle that tempers, the grain to obtain greater energy efficiency and to reduce stress cracking of grain due to high rates of moisture removal. Tempering is also used in some batch dryers and continuous-flow dryers. Although these dryers remove the surface moisture on grain kernels easily, time is required for internal kernel moisture to flow to the kernel's exterior. Tempering the grain provides that time.

Continuous flow in a circular bin dryer can be obtained by using a sweep auger to remove the thin dry layer of grain adjacent to the perforated floor. The dry grain is then elevated to the top of the bin, thus slowly circulating the entire grain mass over the intensive drying area adjacent to the perforated floor.

Dryeration and combination drying facilitate increasing the throughput of a high-temperature dryer, since the grain is cooled not in the dryer, but in a tempering or storage bin.

The dryeration system was developed to prevent stress cracking during high-speed (high temperature and rapid cooling) drying of grain such as shelled maize. An additional benefit of the system is the reduction of heat loss in the cooling phase. In a dryeration system the grain is dried to about two points above its desired storage moisture level, but it is not cooled before it leaves the dryer. The hot grain is transferred into a circular grain bin with a perforated floor and a fan. After 4-6 h of tempering, the fan is turned on and the grain is dried a final two points of moisture as it cools. The dry grain is then transferred to a storage bin. The dryeration bin requires an airflow of 0.5 volume of air per minute per volume of grain based on full bin capacity.

The combination drying system was developed to reduce the cost of fuel for heating the drying air. Grain such as shelled maize is dried to about 19% MC in a high-speed hot air dryer. It is then transferred to a bin-type dryer used as an unheated air or low-temperature dryer, and dried for about a month until it reaches a storage moisture content of 14%. Another

advantage of the combination system is the reduction of stress cracking. The grain is often stored in the final drying bin.

REFERENCES CITED

1. Hall D W (1970) Handling and storage of food grains in tropical and subtropical areas. FAO Agric. Dev. Pap. 90. Food and Agriculture Organization of the United Nations, Rome
2. United States Department of Agriculture (1969) Guidelines for mold control in high moisture corn. Farmers' Bull. 2238. Washington, D.C.
3. Wiggans RG, French O C (1958) Farm storage of ear corn in the northeast. Agric. Exp. Stn. Bull. 926. Cornell University, Ithaca, New York.
4. Duff J B, Toquero T (1975) Factors affecting the efficiency of mechanization in farm level rice post-production systems. Ag. Econ. Pap. 75-04. International Rice Research Institute, P. O. Box 933, Manila, Philippines.
5. Gayanilo V G, Jeon Y W (1987) Sundrying of paddy: effects of mixing frequency and paddy layer thickness on milling quality, moisture content distribution, and drying time. Paper presented at the 10th ASEAN Technical Seminar on Grains Post-Harvest Technology. Aug 1987, Bangkok, Thailand.
6. Lindblad C, Druben L (1976) Small farm grain storage. VITA Manual Ser. 35E. Volunteers In Technical Assistance. Mt. Rainier, Maryland.
7. Jeon Y W, Halos L S, Elepaño A R (1987) Design and performance evaluation of an IRRI pre-dryer. Paper presented at the 10th ASEAN Technical Seminar on Grains Post-Harvest Technology, Aug 1987, Bangkok, Thailand.
8. Stickney R E, Piamonte V N, Belonio A T (1987) DA-IRRI rotary paddy dryer with rice hull gasifier. International Rice Research Institute, P.O. Box 933, Manila, Philippines. p. 4-7.
9. Arboleda J R (1973) Accelerated conduction drying of paddy. Paper presented at the Annual Convention of the Philippine Society of Agricultural Engineers, 25-26 Jan 1973, Manila, Philippines.
10. Canadian Department of Agriculture (1961) Drying and conditioning. Section 3.1. Ottawa, Canada.
11. Grama S, Bern C J, Hurburgh C R (1981) Airflow resistance of mixtures of shelled corn and fines, American Society of Agricultural Engineers Pap. 81-3526. American Society of Agricultural Engineers, St. Joseph, Michigan.
12. Catambay A B, de Padua D B, Arboleda J R (1960) Drying of rough rice with heated air in flat bed dryers. Philipp. Agric. 44(2,3):75.

BIBLIOGRAPHY

- Bockhop C W, Jeon Y W, Halos L S (1983) Design and development of a furnace for efficient burning of agricultural wastes. Paper presented at the 1983 Grains Post-harvest Workshop, May 1983, Sindanglaya, Indonesia.

- Bockhop C W, Jeon Y W, Halos L S (1984) A warehouse-type dryer for drying and storing agricultural commodities. Paper presented at the 10th International Congress of Agricultural Engineering. International Commission of Agricultural Engineering, Sep 1984, Budapest, Hungary.
- Boumans G (1985) Grain handling and storage. *Developments in Agricultural Engineering* 4. Elsevier, Amsterdam.
- Demegillo J A, Maranan C L, Jeon Y W (1985) Technical and economic evaluation of selected types of mechanical dryers. Paper presented at the ASEAN Technology Seminar on Post-harvest Technology, Aug 1985, Manila.
- Elepano A R, Halos L S, Jeon Y W (1982) Rice hull carbonizing and char briquetting. Paper presented at the 37th Annual Convention of the Philippine Society of Agricultural Engineers. Apr 1982, Manila.
- Espanto I H, Andales S C, Belonio A T, Jeon Y W. (1985) Performance evaluation of the IRRI batch-type and rotary drum dryers. Paper presented at the ASEAN Technology Seminar on Post-harvest Technology. Aug 1985, Manila.
- Halos L S, Jeon Y W, Bockhop C W (1983) Design and performance of a multi-purpose dryer using non-conventional energy sources. Paper presented at the 33rd Annual Convention of the Philippine Society of Agricultural Engineers, Apr 1983, Baybay, Leyte, Philippines.
- Jeon Y W, Halos L S, Bockhop C W (1982) Design of a center-tube type furnace for efficient rice hull burning. Paper presented at the National Workshop on Rice Husk for Energy, Aug 1982, New Delhi, India
- Lawand T A (1966) A solar-cabinet dryer. *Solar Energy* 10:4.
- Ripp B E, Banks HJ, Bond E J, Calverley DJ, Jay E G, Navarro S, eds. (1984) *Controlled atmosphere and fumigation in grain storages*. Elsevier, New York.
- Vo-Ngoc D, Longval J R, Srivastava N K, Jeon Y W, Halos L S (1987) Wind tunnel testing of IRRI vortex wind machine. Paper presented at the 10th ASEAN Technology Seminar on Grain Post-harvest Technology, Aug 1987, Bangkok, Thailand.
- Wimberly J E (1983) *Technical handbook for the paddy rice postharvest industry in developing countries*. International Rice Research Institute, P.O. Box 933, Manila, Philippines.

11 Transport

Good transport is essential both for getting produce to market and for getting urban goods to rural areas. It is important that transport be both efficient and cost effective. In the late 1970s, a large foreign aid project in North Shaba Province of Zaire attempted to increase the production of maize for the workers in the mines and factories of South Shaba. Much money was spent in the local manufacture of hand tools, training centers for agricultural cooperatives, special programs for women, an extensive maize breeding program, and road-building. Analysis surprisingly revealed that the most important factor in increasing maize production in the project area was road construction. The roads allowed the grain traders to drive their trucks to the farm villages to purchase the maize.

Good roads encourage transport for both goods and people. This chapter is about the various means of transport used to move produce from the farm to the main highways, railway depots, or market towns.

Transportation by boat is admittedly important. In some countries such as Bangladesh, much produce is transported by waterways. Only land transport, however, will be discussed in this chapter.

11.1 Manual transport Transporting cargo by humans was discussed briefly in Chapter 1. Carrying poles, handcarts, and bicycles are improvements on carrying headloads long distances, but a bicycle requires at least a smooth trail, and handcarts require roads.

The energy required to propel a wheeled vehicle such as a bicycle, wheelbarrow or handcart depends on the road surface, the wheel size and construction, the type of wheel bearing, and the height of the load. In general, the larger the

wheel diameter, the better, for a large-diameter wheel is less affected by pebbles and surface unevenness than a small one. The width of the wheel is not very important on a smooth, hard surface; but on soft soil, a wide wheel will offer lower resistance to rolling than a narrow wheel. The importance of this phenomenon is illustrated by the fact that indigenous vehicles for rural use, from the wheelbarrow in China to oxcarts in India and Paraguay, have large wheels with wide rims. The pneumatic tire, with its ability to absorb the pebbles or road irregularities that cause sudden resistance to the forward motion of a steel-rimmed wheel, is preferable to a steel wheel for a human-powered vehicle.

Although wood bearing and steel axle or babbitt bearing and steel axle combinations are quite satisfactory for wheeled vehicles, these types of bearings are frequently of poor quality in developing countries. Thus, for manually powered vehicles, sealed precision ball, tapered roller, or needle bearings are preferred.

11.1.1 Carrying pole. Bamboo carrying poles such as the one illustrated in Figure 11.1 are an important means of transporting goods in Asia. Carrying poles provide the bearer a high degree of mobility, yet allow transportation of heavy loads—

11.1. Bamboo carrying pole.

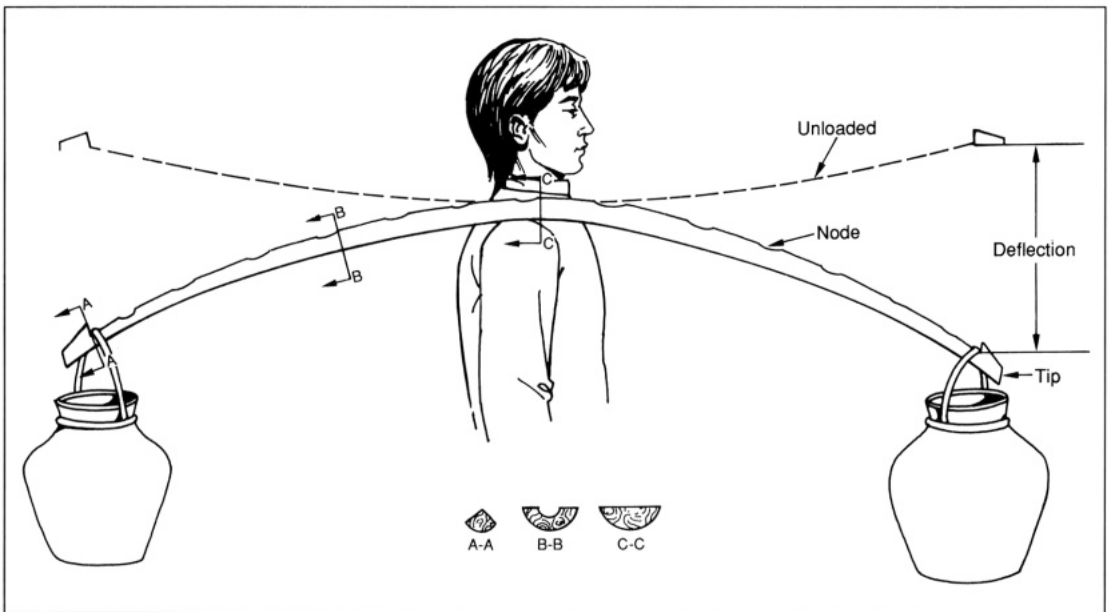

up to 100 kg. Carrying poles are semicircular in cross-section and usually about 2 m long, with tapered ends. The load is suspended from the ends, and the weight is positioned over the bearer's center of gravity. By contrast, a load carried in the arms must be supported in an awkward, off-center, fatiguing posture that can strain the lower back muscles.

A properly designed carrying pole acts as a leaf spring and reduces the magnitude of the shock load when the bearer lifts the burden with a vertical movement. Although the load carried by the bearer remains constant regardless of how the burden is carried, the less shock load transmitted to the bearer, the less tiring is the carrying of the load.

One analysis of the bamboo carrying pole describes it as a *single degree of freedom spring-mass system*.¹ The analysis assumes that the mass of the spring is negligible in comparison with the load, and any damping is small. The natural frequency of the carrying pole and the load depends on the weight of the load and the spring rate of the pole. The bearer's stride in steps per second is called the *driving frequency*. If the pole were rigid, the bearer would receive a peak shock load each step. However, a fairly constant load on the shoulder is more comfortable and less fatiguing than a cyclic shock load. By tuning the spring rate and the weight of the load to the bearer's stride, the shock loads on the bearer's shoulders can be greatly reduced. Figure 11.2 illustrates how the shock loads occurring with a rigid pole can be reduced with a properly designed flexible carrying pole.

11.2. load on bearer vs time with rigid and flexible poles.

TR = Transmissibility.

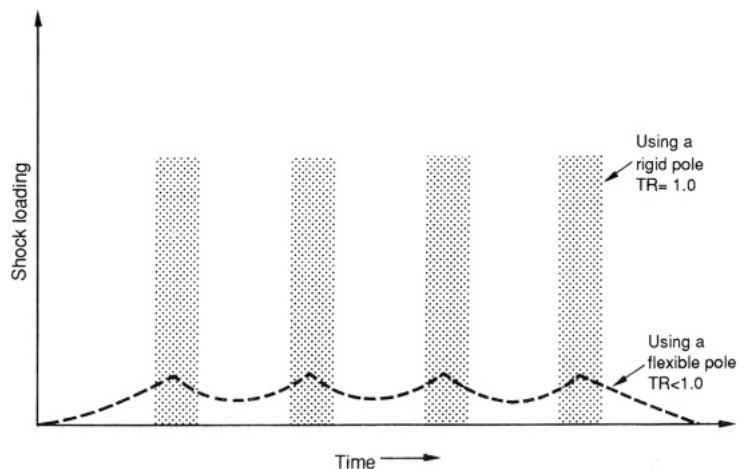

The shock loading can be reduced by stepping more rapidly or by increasing the deflection of the pole. The pole deflection can be increased by using a more flexible carrying pole.

Bamboo is a natural composite material, and a typical bamboo carrying stick has a spring rate of 24 N/cm (13.7 lb/in).² In other words, a force of 24 N deflects the carrying stick 1 cm. A person striding 180 steps per minute and carrying a load of 54 kg (120 lb) will experience a shock loading only one-third as great as if carrying the load at the same speed on a rigid pole.

Once the bearer's stride in steps per minute and the weight of the load are known, the carrying pole can be designed to a specific transmissibility of the shock load using the graph in Figure 11.3, which shows the pole deflection required to secure a specific transmissibility of shock load according to the bearer's gait.

A person with a gait of 120 steps per minute who wishes to reduce the transmissibility of shock load to one-fourth the peak load will need a carrying pole with a deflection of 30 cm. To obtain this condition and carry 80 kg (40 kg on each end of the pole), the carrying pole must deflect 30 cm under a load of 40 kg—a spring rate of 13 N/cm (7.5 lb/in).

11.3. Transmissibility of shock load vs gait.

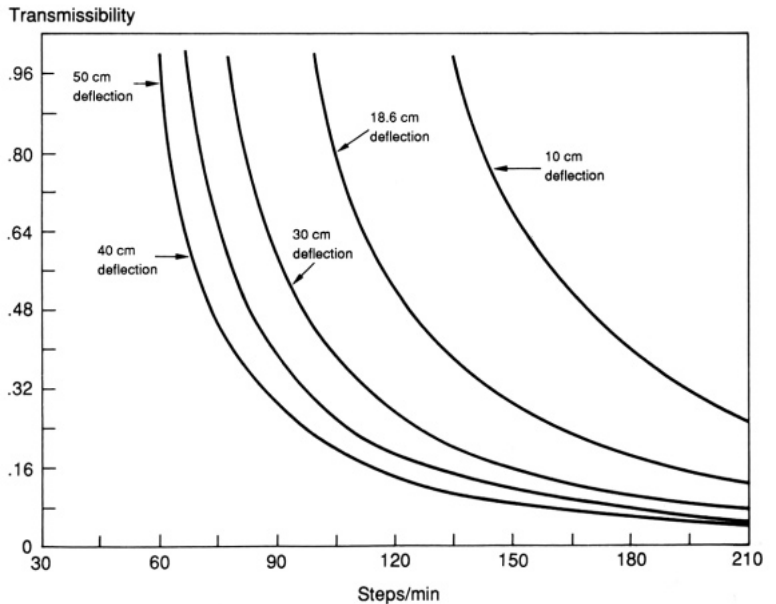

As a rule, the driving frequency should be two to three times the natural frequency of the pole and load for effective reduction of the shock load. When the ratio of driving frequency to natural frequency is less than 1.41, the system will resonate and create a transmissibility greater than one.

11.1.2 Bicycles. It appears to be a paradox that a person can move himself and a machine (bicycle) weighing 10-20 kg with less energy than if he were moving on foot at the same speed. An analysis by Tucker compared the efficiency of moving of various animals, man, and transport devices by using a dimensionless quantity ($P_i \div WV$).³ P_i is the power input commonly known as the metabolic rate, W is the weight of the animal or human, and V is the velocity of the animal along a level path.

When an active muscle shortens, it does mechanical work. When it lengthens work is done on the muscle.

Active muscles stretching as well as shortening during locomotion are characteristics of walking and running in humans and in other terrestrial bipeds and quadrupeds. The necessity for muscle stretching seems to be associated largely with the cyclic acceleration and deceleration of the animal's center of mass during running. The leg muscles shorten, accelerating the animal upward and forward; later in the step cycle, the center of mass falls and the active muscles are stretched as they slow its rate of descent and forward motion. To begin a new cycle, the muscles then shorten again. An alternate strategy for running animals is to prevent active muscles and elastic structures from stretching at all. This can be accomplished by means of a mechanism that converts the downward velocity component of the body's center of mass at the end of one step cycle to the upward component at the start of a new cycle without either storing mechanical energy elastically or degrading it to heat. The mechanism applies a force to the center of mass at right angles to its direction of motion.⁴

A bicycle is such a mechanism. Muscle efficiency while pedaling a bicycle is high—about 25%—because the active muscles are not stretched as much while pedaling as they are while walking or running. Furthermore, the wheel stabilize

the rider's center of mass so that it does not move up and down as when running or walking, but rather moves in a level plane. Body mass is not lifted with each pedal stroke as it is with each step while walking. The energy thus saved can be used by the bicyclist to propel himself and the bicycle forward.

The fastest humans can run a mile in just under 4 min—about 24 km/h (15 mph). A bicycle, however, can reach a speed of nearly 100 km/h (62 mph).

A bicycle used for transporting freight has larger axles, stronger wheels, and a heavier frame than a touring bicycle. Loads are usually carried in a pair of panniers on each side of the rear wheel. Additional loads are sometimes balanced on the handlebars or fixed to a carrier over the front wheel. A load of up to 200 kg can be carried on a bicycle.

A tricycle suitable for transporting freight or passengers is made by replacing one of the wheels of a bicycle with a bed or seat and a pair of wheels set 1-1.5 m apart. In Asian countries such as Bangladesh and Indonesia, a pedicab is constructed by lengthening the frame and replacing the rear wheel of the bicycle with a wide axle, two wheels, and a seat with canopy. Two or more people sit facing the direction of travel. The operator steers with handlebars. In other countries, such as Peru, a tricycle for freight and passengers is created by lengthening the frame and replacing the front wheel with an axle, two wheels, and a box or platform (Fig. 11.4). The operator steers with a handlebar fastened to the rear of the box.

Although multispeed gearshifts might prove advantageous for bicycles used for transport, those bicycles currently used are primarily of a fixed gear ratio.

11.1.3 *Wheelbarrows and handcarts.* Wheelbarrows are commonly used on farms because they can move cargo on paths where two-wheel carts cannot go. Also, they can be turned sharply in restricted areas. Pneumatic tires are preferable to keep rolling resistance to a minimum. If the wheel is steel-rimmed, it should be large in diameter—at least 50 cm—and the rim should be about 10 cm wide.

The European wheelbarrow (Fig. 11.5) is operated by one person and is designed to carry up to about 100 kg over short distances. The Chinese wheelbarrow (Fig. 11.6) is designed

11.4. Tricycle with passengers and cargo (Peru).

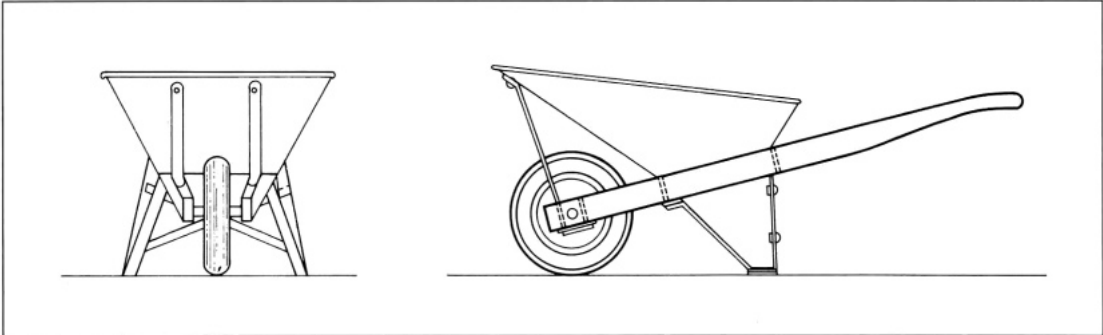
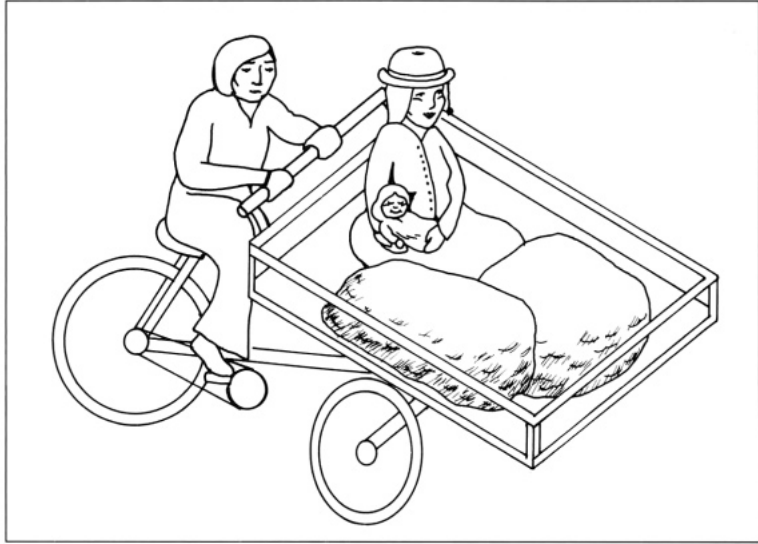

11.5. European wheelbarrow.

11.6. Chinese wheelbarrow.

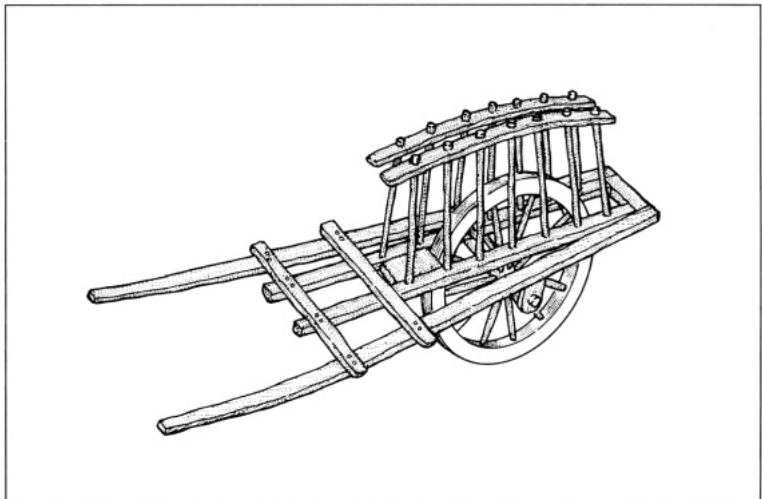

to carry about 250 kg (550 lb) over long distances, with one man between the handles pulling against a strap, and, if necessary, another person pushing at the rear. The Chinese wheelbarrow is designed so the load is balanced on the large wheel (nearly 1 m in diameter). The wheel is secured to the center of the wooden frame so that the weight on the handles does not exceed 20 kg.⁵

The European wheelbarrow is constructed so that the wheel, which is located in front, carries a little over half the load. The operator lifts the remainder of the load by the handles. Since pneumatic tires have much less rolling resistance than steel-rimmed tires, many European wheelbarrows are manufactured with small-diameter pneumatic tires (instead of steel wheels for similar wheelbarrows) so that the wheel can be set closer to the operator, thus carrying a greater percentage of the load.

A steel wheel running on a steel rail has a very low coefficient of friction. In the Philippines, passengers and farm produce are transported on public railroad lines by trolleys (called rail cars or skates in some countries), which are owned and pushed by private entrepreneurs (Fig. 11.7). The trolley consists of a wooden platform about 1.3m square with a split

11.7. Rail car (Philippine trolley).



bamboo floor and a bench for passengers. The platform rides on four ball bearings. Four smaller ball bearings are mounted underneath and ride against the inside of the rails to keep the trolley on the track. The trolley is propelled by the operator pushing off on one rail with one foot while standing on the trolley with the other foot and pushing against a bar on the rear of the passenger bench. Normal speed is 15 km/h. A piece of trucktire attached to the platform and trailing on the rail serves as a brake. By stepping on the piece of tire, the operator can bring the vehicle to a halt.

The trolley is lightweight, as it must be removed from the track when a train approaches. Since the trolleys run on single-track rail lines, unwritten rules of the road have evolved that require a lightly laden trolley to make way for an approaching, heavier laden one; a trolley with young passengers must make way for one with older passengers; and a trolley with male passengers must make way for female passengers. Such a trolley can easily transport 0.5 t of grain and several people from one village to another.

Monorails are used in some rough tropical areas to transport bananas. The bananas are hung from carriers that ride on the monorail on steel wheels mounted on antifriction bearings. An operator pulls the train of bananas from collection depots on the plantation to a highway, where they are loaded into trucks,

Some monorails are equipped with a carrier powered by a 5-hp engine and equipped with a seat so the operator can ride.

11.2 Animal transport

Much of the world's produce is transported by animals. (Several means of animal transport were discussed in Chapter 1.1) Where only trails exist, animal-borne goods must be carried in packs cinched to the animals' backs or in panniers. The common large draft animals such as horses, mules, donkeys, bullocks, water buffalo, and camels can pull much greater loads than they can carry. Sleds and wheeled vehicles are utilized where roads are available.

The dogsled and the horse sleigh are romantic, but carry little or no farm produce. The sled important to agriculture is the wooden sled used to haul loads over fields and roads close to the Farm. A typical farm sled is 20 cm high, 180 cm long, and 75 cm wide. The sled is low to the ground and is

very useful for hauling heavy objects such as stones. In Southeast Asia, sleds drawn by water buffalo are frequently used to carry seedlings at transplanting time and small threshers during harvest. Depending on the surface and slope upon which the sled rides, it can carry up to 400 kg.

A wooden sled runner on a dry smooth stone surface has a coefficient of sliding friction (f) of 0.38, while on snow or ice f_s is 0.035. If the sled runners have metal shoes, f_s is 0.02.⁶ The draft required to pull a sled is equal to f_s times the gross load of the sled. So a wooden sled with a gross weight of 200 kg, running on dry, smooth stones requires a draft of $0.38 \times 200 \text{ kg} = 76 \text{ kgf}$ (745 N). On wet grass or a wet but firm wetland field, the draft is less.

It is estimated that only 50% of India's 600,000 villages are connected by all-weather roads, and one-third of all freight is transported by animal power. Of the 15 million animal-drawn vehicles in India, 12 million are located in rural areas, where work animals are kept primarily for plowing. Using these animals for pulling carts, like the one in Figure 11.8, doubles their usefulness and provides additional employment for their owners.⁷

The large wheels and height of bed of the cart in Figure 11.8 allow the shoulder yoke to sit on the bullocks. The driver

11.8. Cart drawn by a pair of bullocks (India).

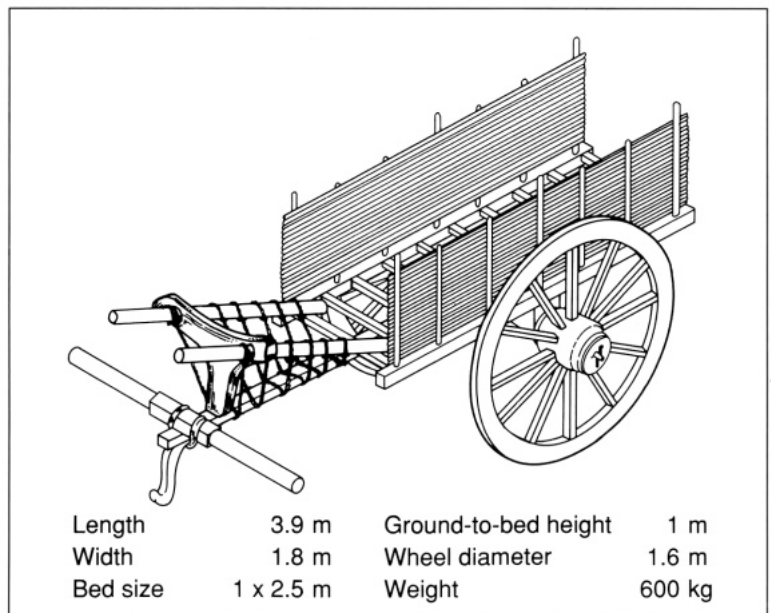

sits astride the poles above the tongue between the two animals. The driver's proximity to the animals' heads permits him to control them with a short goad or whip, as well as verbal commands.

The amount of draft required to pull a wheeled vehicle can be calculated by multiplying the gross axle weight by the coefficient of rolling friction using the equation

$$D = f_r \times L$$

where D = required draft,
 f_r = coefficient of rolling friction, and
 L = load

The equation assumes that the wheel hearings are in good condition and well lubricated, that the load is being pulled on a level surface, and that the force required to accelerate the load to the vehicle's operating speed is not included.

The coefficient of rolling friction varies according to the type and size of tire and the surface being traversed (see Table 11.1). For example, a bullock cart with a gross load of 1,000 kg on two 4 x 36 steel-tired wheels and on grass sod requires a draft of 74 kgf (726 N, 163 lb) as shown by the equation

$$D = f_r \times L$$

$$D = 0.074 \times 1,000 \text{ kg}$$

$$D = 74 \text{ kgf}$$

If the same cart were in loose sand, the required draft would be 413 kgf (4050 N, 909 lb).

If all the weight of both the vehicle and load are carried by the wheels and all wheels are the same size, the draft required to pull the load is easily obtained by multiplying the gross weight by the coefficient of rolling friction. If the wheels are not the same size, draft can be calculated by individually calculating the draft required for the load carried by the front wheels, and the load carried by the rear wheels, and summing the two drafts.

The rolling resistance of a pneumatic tire consists of two parts: the flexing of the tire carcass and the resistance of the surface to deformation. Rolling resistance is caused primarily by tire flexing on a paved surface, or by soil deformation on soft ground. The draft of a vehicle equipped with pneumatic tires can usually be reduced on a hard surface by inflating the

Table 11.1. Coefficients of rolling friction for steel wheels and pneumatic tires.⁸

Wheel	Load per wheel in lb(kN)	Inflation pressure in psi (kPa)	Coefficient of rolling friction			
			Concrete pavement	Grass sod	Tilled loam	Loose sand
2.5 × 36 steel	1,000(4.45)	–	.010	.087	.384	.431
4 × 36 steel	1,000(4.45)	–	.019	.074	.367	.413
6 × 28 steel	1,000(4.45)	–	.023	.094	.368	.477
8 × 48 steel	1,500(6.67)	–	.013	.065	.236	.264
4 × 30 4-ply	1,000(4.45)	36(248)	.018	.057	.322	.319
4 × 36 4-ply	1,000(4.45)	36(248)	.017	.050	.294	.277
6.00 × 16 4-ply	1,000(4.45)	20(120)	.027	.060	.319	.338
7.50 × 10 4-ply	1,000(4.45)	20(120)	.029	.061	.379	.429
7.50 × 16 4-ply	1,500(6.67)	20(120)	.023	.055	.280	.322
7.50 × 28 4-ply	1,500(6.67)	16(110)	.026	.052	.197	.205
7.50 × 36 4-ply	1,500(6.67)	16(110)	.018	.046	.185	.177
9 × 16 6-ply	1,500(6.67)	16(110)	.042	.054	.249	.272

tires to the upper limit of allowable inflation pressure. When operating on soft soil, the tires should be deflated to the lower range of inflation pressure, or slightly underinflated.

To move a vehicle up a hill requires more draft than to move it at the same speed on a horizontal surface. A slope or incline is generally described as a "grade" such as "1:20" or as a "percent" such as "5%." Both nomenclatures describe a hill by stating the units of vertical rise for 100 units of horizontal distance. For example, a road with a 1:20 grade or a 5% slope rises 5 m for every 100 m of horizontal distance. In this example, the gross weight of the vehicle is actually lifted 5 m for every 100 m the vehicle travels horizontally. The increased draft required to move a vehicle up a slope is proportional to the slope. A cart with a gross weight of 1,000 kg going up a 10% grade will require 100 kg more draft (10% × 1,000 kg = 100 kg) than for the horizontal.

To calculate the power to pull a vehicle up a hill, the total draft is equal to the draft to overcome rolling friction plus the draft required by the slope of the hill. For example, if the bullock cart described on page 283 is pulled up a 7% grass sod slope at 3 km/h, the bullocks will need to expend 1.6 metric hp.

$$\text{hp}_{\text{metric}} = [(\text{draft overcoming rolling friction}) + (\text{overcoming the hill})] \times \text{speed} \div 270$$

$$\begin{aligned} \text{hp}_{\text{metric}} &= [(.074 \times 1,000 \text{ kgf}) + (7\% \times 1,000 \text{ kgf})] \times 3 \text{ km/h} \div 270 \\ \text{hp}_{\text{metric}} &= (74 \text{ kgf} + 70 \text{ kgf}) \times 3 \text{ km/h} \div 270 = 1.6 \text{ hp} \end{aligned}$$

Farm wagons have four wheels and are usually larger than carts. Since the weight of the load being transported is supported totally by the wheels, none of the load is carried by the animals drawing the wagon. Steering of farm wagons is accomplished either by a fifth wheel or an automotive-type steering mechanism. The fifth wheel-type of steering provides very sharp turning. The front axle is attached to a horizontal disc or large bearing, which is fastened by a pin to a stationary disc on the bottom of the wagon. To keep the bottom of the wagon box at a reasonable level, however, it is usually necessary to make the front wheels of smaller diameter than the rear wheels, since the front wheels must pass under the wagon box. Few farm wagons or carts are equipped with springs. In many European countries, the law requires that farm wagons be equipped with brakes. In the rest of the world, such regulations do not exist or are not enforced. Most animal-drawn wagons have some sort of mechanical wheel brake, while tractor-drawn wagons depend on the tractor for braking.

Today, most farm wagons use pneumatic tires, since they provide lower rolling resistance than steel-rimmed wheels. They also provide a softer ride for the farmer. Wagons are frequently equipped with worn truck tires, which are quite suitable.

11.3 Tractors

Transportation is an important function of pedestrian and farm tractors. In countries, such as Pakistan, as much as one-third of tractor hours are used for transport. The tractor is used to pull a wagon or trailer filled with goods or people (Fig. 11.9). Transportation provides the tractor owner with income when the agricultural calendar does not require the tractor for tillage, threshing, or fieldwork. For this reason, tractors with high-speed road gears are preferred by owners. If a tractor is used frequently on paved roads, the rear tire lugs develop sharp edges because, as the tire squeezes from the load, some rubber will be abraded from the lug, and the edges of the lugs will remain sharp. A tractor that is used only in fields will exhibit tires with rounded edges and the tire lugs.

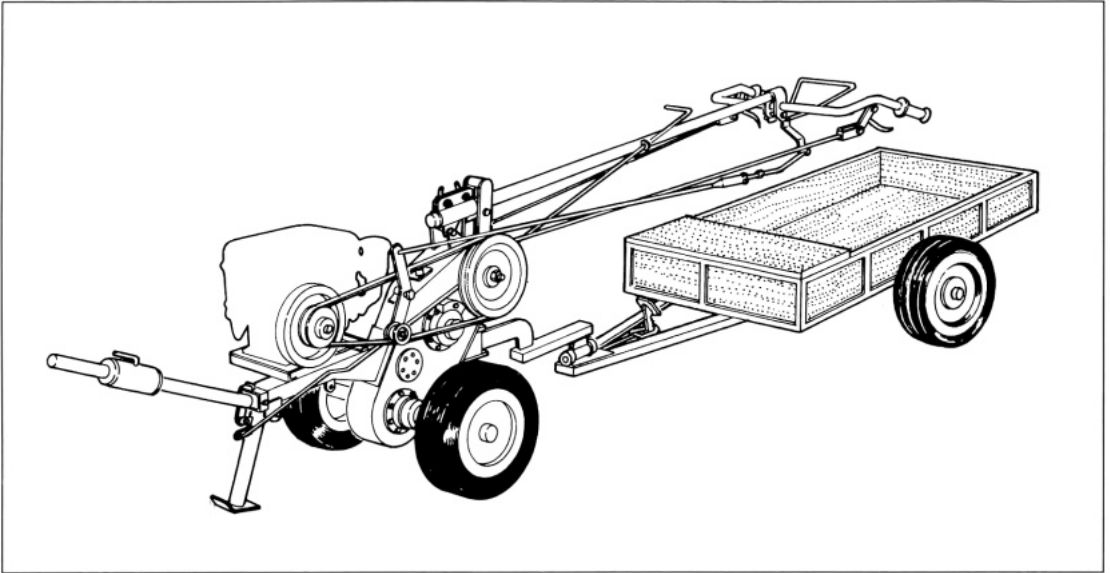

11.9. Pedestrian tractor and trailer.

Some tractor manufacturers provide an air compressor and air brake system as optional equipment. Another option is a standard highway truck trailer coupling that enables tractors to pull four-wheel high-speed truck trailers over local roads to small villages (Fig. 11.10). Because the hitch for highway trailers is higher than the tractor axle, the tractor must be properly weighted in front and accelerated with care.

11.10, Farm tractor with highway trailer hitch and brake connections.

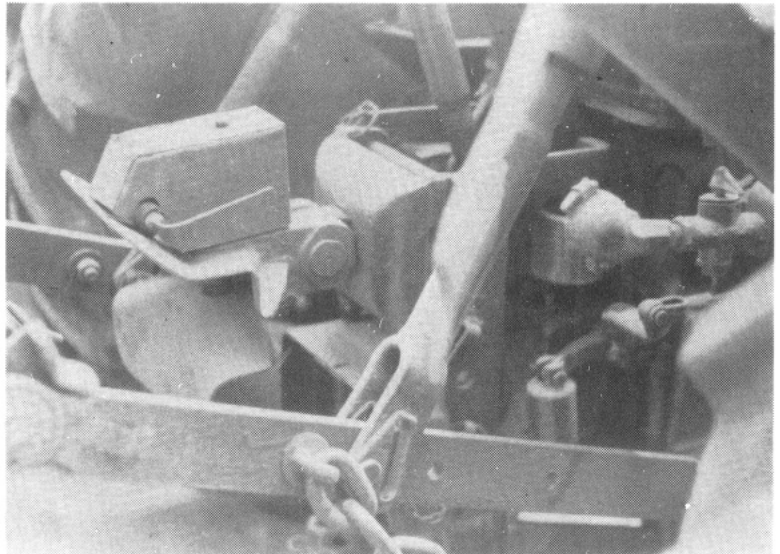

Front-end hydraulic loaders and forklifts (Fig. 11.11), or platforms mounted on a tractor's three-point hydraulic lift, provide versatile means of transporting material for short distances. The front-end loader is usually equipped with a bucket. Not only can the loader be raised and lowered, but it can be tipped hydraulically. The bucket is normally used for jobs such as moving manure or scooping grain, but it is also utilized to move items as diverse as firewood, bags of feed, concrete blocks, bags of cement, and stones. Other options for the front-end hydraulic loader include grappling hooks for grasping and moving large round bales, compression tongs for moving blocks of about eight small rectangular bales, and pairs of pallet for for moving boxes of fruit or produce such as potato in the field.

By attaching a pair of pallet forks to a small platform (100 x 150 cm) on the rear 3-point hitch, the farmer has a hydraulic platform by which loads can be lifted from ground level to the height of a wagon bed or loading platform. Rear forks are used to move large round bales (Fig. 11.12), and the small platform is used for moving bags of feed and cans of milk. Most farm tractors meet the ASAE standard for the 3-point hitch, which specifies that at a point 2 ft (61 cm) to the rear of the lower lift links, a farmer can expect a minimum lift force of 1040 lb (4.6 kN).

Trailers are very useful, since they can be turned very sharply when hitched to a tractor. The weight on the trailer hitch and thus on the drive wheels of the tractor help increase

11.11. Front-end loader.

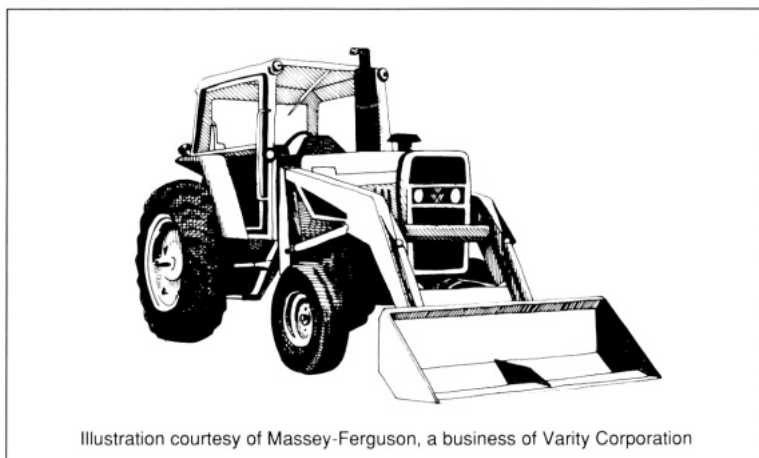

11.12. Large bale being loaded onto rear forks.

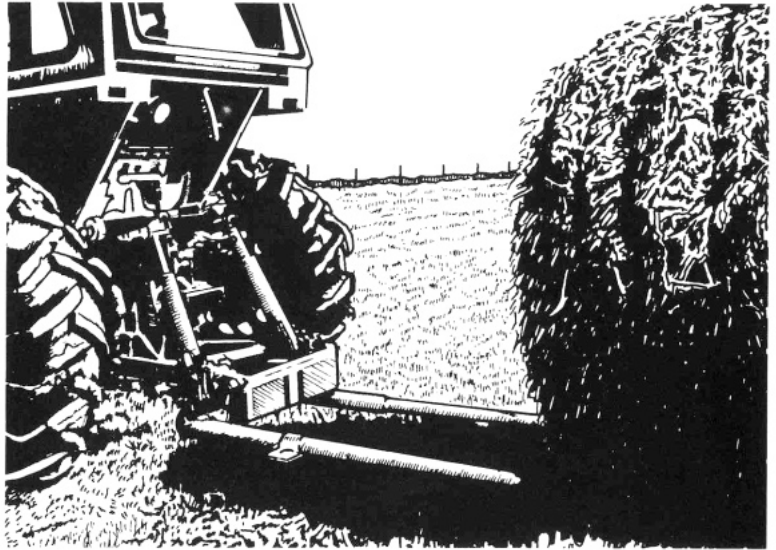

drive wheel traction. Farm trailers normally have a capacity of 4-10 t.

Tractor trailers are often designed for the bed to be lifted at the front by the tractor's hydraulic system, so that bulk loads can be dumped from the rear. Specialized high-lift trailers for hauling vegetables are made with a rectangular lifting mechanism so that the tilted bed can be lifted 3 m (10 ft)—enough to reach over the high sides of highway trucks.

Farm wagons in North America and many other areas are usually purchased as two components—running gear and wagon box. The running gear consists only of the axles, wheels, and frame. The wagon box is either a covered forage box for towing behind a field forage harvester, a flatbed for hand stacking baled hay or apple crates, or a box with a perforated floor for forced-air drying of peanuts or grass seed crops. If a farmer expects to be hauling very heavy loads, or to be operating on soft soil, a higher capacity running gear with large tires will be selected. To provide adequate flotation, yet keep tire diameter from becoming excessive twin axles fitted with a walking beam are used as the rear axle. They are then positioned to carry most of the load. The walking beam axle provides good support on uneven ground (Fig. 11.23). Tires of adequate size must be used on a wagon on a soft field to prevent it from bogging down.

11.13. Forage wagon with walking beam tandem axle.

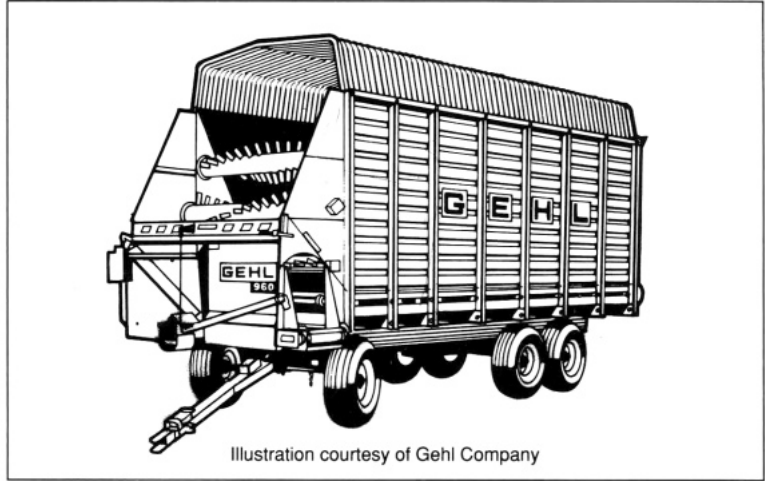

11.14. Feed-mixing wagon.

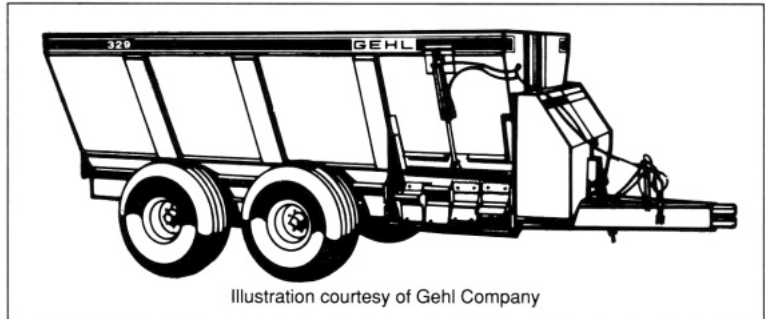

Several types of specialized wagons and trailers are available. Automatic bale-loading wagons can pick up and automatically stack hay or straw bales. Feed-mixer wagons with electronic weigh cells placed between the running gear and mixer box facilitate mixing various feed (Fig. 11.14). Grain boxes with sloping sides so the box will empty cleanly when a bottom port is opened are used to haul grain from a combine to a dryer or storage area. Boxes with sloping slides and a center conveyor belt transport root crops such as potato, red beet, and sugar beet. Some specialized trailers, such as the automatic bale-loaders, do not fit onto separate running gear. Their axles and wheels are an integral part of the whole machine.

REFERENCES CITED

1. Campbell O F (1984) The ergometrics of a bamboo carrying stick. Cornell University. (unpubl.)
2. Lakkad S C, Patel J M (1981) Mechanical properties of bamboo, a natural composite. *Fibre Sci. Technol.* 14(1980-81):319-322.
3. Tucker V A (1975) The energetic cost of moving about. *Am. Sci.* 63:413-419.
4. *Ibid.*, pp. 417-418.
5. Hoffen HJ, Biesalski E (1953) Small farm implements. FAO Dev. Pap. 32. Rome, Italy.
6. Baumeister T, Marks L S. ed. (1967) Standard handbook for mechanical engineers. 7th ed. McGraw-Hill Book Co., New York. p. 3-39.
7. Ramaswamy N S, Narasimhan C L (1984) India's animal-drawn vehicles Indian Institute of Management, Bangalore.
8. McKibben E G, Davidson J B (1939) Transport wheels for agricultural machines. *Agric. Eng.* 20(12):471.

BIBLIOGRAPHY

- Barwell I J, Edmonds G A, Howe J S G F, DeVeen J (1985) Rural transport in developing countries. Intermediate Technology Publications, Ltd., London.
- Hathway G (1978) Appropriate technology in rural development: vehicles designed for on and off farm operations. Transportation Department, World Bank, Washington, D.C.
- Hathway G (1985) Low-cost vehicle. Intermediate Technology Publications, Ltd., London.
- McKibben E G, Hull D O (1940) Transport wheels for agricultural machines; soil penetration tests as a means of predicting rolling resistance. *Agric. Eng.* 21(6):231-234.
- Whitt F R, Wilson D G (1982) *Bicycling science*. 2d ed. MIT Press, Cambridge, Massachusetts.
- Wooley J C, Jones M M (1925) The draft of farm wagons as affected by height of wheel and width of tire. *Univ. Missouri Bull.* 237.

12 Social consequences

When mechanization is introduced in agriculture, skeptics often ask, “Doesn’t mechanization make the rich richer and the poor poorer?” The question has some justification, for machinery can indeed replace humans in some agricultural jobs. Other appropriate questions, however, can also be posed. “Does mechanization help produce more food and fiber?” “Does mechanization alleviate toil and improve the quality of the farmer’s life?”

Disagreement concerning the desirability of agricultural mechanization frequently arises because the machinery itself is blamed for unequal distribution of the crop yield increase. Critics point out that even when mechanization increases the output of the agricultural system, the laborers do not receive a proportionate share of the surplus. Unfortunately, this is often true. In socially stratified countries, where land tenure and inequality are the norm, technological inputs such as agricultural machinery are unlikely to stimulate abrupt social change. Agriculturists and engineers have often succeeded in increasing food production in LDCs by introducing modern varieties, methods, and machinery. Social and political scientists, however, have been largely unsuccessful in improving the equity of distribution. It is difficult for a foreigner to advise an old and stable society to revise its social structure. Social change within a country must develop from its own citizenry.

12.1 Mechanization and agricultural employment

In many agricultural countries, nonmechanized agriculture provides some employment to persons who in industrial nations would be receiving food stamps or would be living on the dole because of lack of income. This method of production involves high labor input per unit of food produced and very low wages for the workers. It cannot be

labeled good or bad, since a country's agricultural system depends on both its notion of social justice and its agroclimatic conditions.

A study examining the changes in employment, production, and income resulting from small rice farm mechanization in the Philippines, Thailand, and Indonesia revealed that mechanization reduced labor requirements during land preparation. Total labor output was higher during the dry season than the wet season, except for farms irrigated by gravity systems (Fig. 12.1).

Figure 12.1 illustrates that in both the wet and dry seasons, labor days per hectare of rice decreased. The decrease was most apparent during land preparation and threshing. These tasks, of course, are normally the first to be mechanized. A significant difference in the amount of hired labor between

12.1. Labor for rice production in two Philippine villages.¹
 NM = nonmechanized,
 PM = partially mechanized.

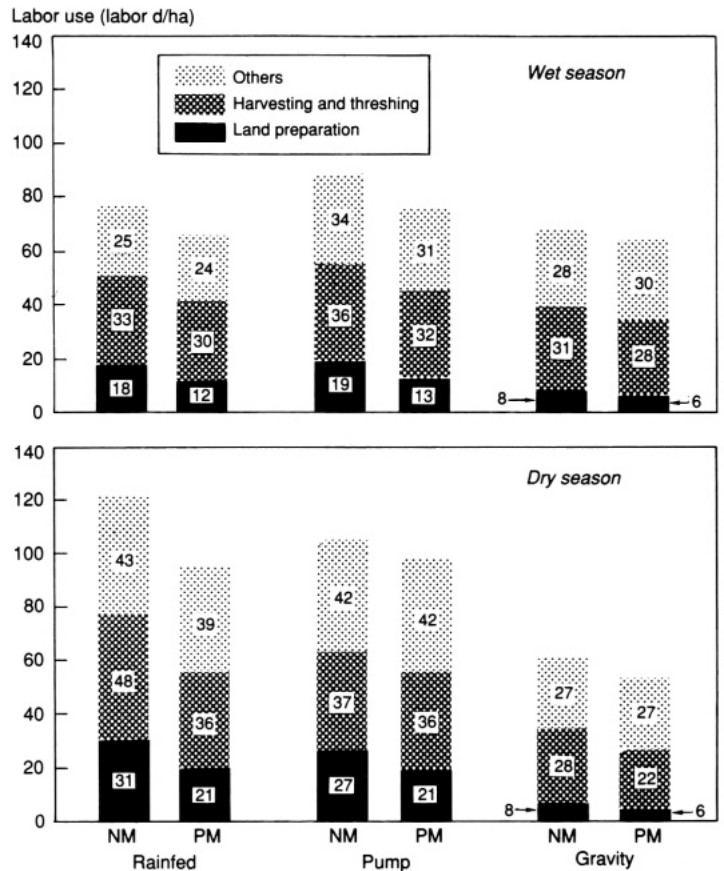

mechanized and nonmechanized farms was not apparent. However, permanent labor and seasonal hired labor were used differently. The major reduction of labor benefited the farmer's family.² Data from West Java and South Sulawesi, Indonesia, revealed the same trend. In general, labor requirements per hectare of rice declined, hired labor increased on most mechanized farms, and the major reduction of labor on mechanized farms was enjoyed by the farmer and the farm family.³

Another Philippine study used 1978 data to calculate the effect on employment from a 1% increase in consumer spending for rice.⁴ The study predicted that a 1% rise in consumer spending for rice would increase employment in the Philippines by 23,000 workers using full mechanization under nonirrigated condition, and by 53,000 workers if a low level of mechanization were used under pump-irrigated conditions. The increase in jobs would affect not only farm labor, but (more importantly) labor in the nonagricultural sector. The projected effect of the type of threshing is shown in Table 12.1; manual threshing produces 22% more work in agriculture than the use of portable mechanical threshers does. In the nonagricultural sector, however, the portable mechanical thresher produces 2% more work than manual threshing. In total, under the condition of a 1% increase in rice production, manual threshing requires more hours of labor than mechanical threshing, but the increase is primarily in the agricultural (not nonagricultural) sector.⁵

12.2 Mechanization and crop yield

In a rice-growing area in Central Luzon in the Philippines, a study was made to investigate the differences in inputs, cropping intensity, and yield for nonmechanized. partially

Table 12.1. Employment implications of threshing method for a 1% increase in rice production in the Philippines.⁶

Method	Employment		
	Agricultural sector (direct)	Nonagricultural sector (indirect)	Total
Manual threshing. 1000 labor-yr	15.9	27.1	43
Mechanical threshing. 1000 labor-yr	12.4	27.6	40
Difference (%)	22	2	7

mechanized, and fully mechanized farms in nonirrigated and irrigated areas. The irrigated areas were classified into rainfed, pump-irrigated, and gravity-irrigated. The classes of mechanization were based on the type of power utilized for land preparation in both the wet and dry seasons. Non-mechanized farms used draft animals for land preparation in both seasons, while fully mechanized farms used pedestrian tractors or farm tractors in both seasons. The farms using a combination of animal and mechanical power were classified as partially mechanized.⁷

The study revealed that irrigation was the major determinant of yield and cropping intensity, and that there was no evidence of a yield effect directly attributable to mechanization (Table 12.2). These findings support similar studies of nonmarginal agricultural production systems (that is, systems that do not have a narrow rime frame during which tillage, seeding, or some other element of the agricultural calendar must be accomplished if a crop is to be produced.)

Mechanization shortens the turnaround interval between crops. Turnaround time for a mechanized rice farm vs a nonmechanized farm is substantially reduced because the farmers control irrigation by utilizing their own wells and pumps. For community gravity irrigation systems, little or no difference in turnaround time exists between mechanized and nonmechanized farms. The cropping sequence is determined by irrigation water, which becomes available to both mechanized and nonmechanized farms at the same time.

In areas where the growing season is limited, mechanization can increase crop yield. For example, in the U.S. corn belt there is an optimal period of a few weeks in which to plant maize. If planting cannot be accomplished during this time frame, yield reduction will result. For this reason, 8- or 12-row

Table 12.2. Rice productivity in selected villages in Guimba and Cabanatuan, Nueva Ecija, Philippines, 1979 wet season.⁸

Rough rice yield	Rainfed		Gravity-irrigated	
	Nonmechanized	Partially mechanized	Partially mechanized	Fully mechanized
ln kg/ha	1902	1826	3860	3803
ln kg/kg of nitrogen	76	63	74	73
ln kg/8 h of labor	25	28	58	-59

maize planters are often preferable to 4- or 6-row units.

Timeliness is more important in nonirrigated than in irrigated regions. Capacity utilization, when a machine is used over a large area to lower costs, is frequently incompatible with timeliness.

12.3 Mechanization and farm income

In sub-Saharan Africa, a comparative study of hand-hoe households and farm households mechanized by the introduction of animal traction revealed that the latter households had net returns higher by 2-5 times.⁹ However, the farms using animal traction were typically larger and had more household members than the hoe-farms, so the differences were not quite as large on the basis of revenue per hectare or per capita.

A study in the Philippines where three classes of rice farm mechanization—animal and tractor, and tractor—were compared revealed that mechanization significantly affected income on large (2.5 ha and over) farms. An economy of scale was noted in the use of machines on larger farms.¹⁰ Income data for the classes of farms in the study are shown in Table 12.3.

12.4 Affordable technology

A farmer cannot purchase farm machinery to improve his quality of life if conditions beyond his control such as government policies and transport conditions keep crop prices low. A revealing comparison of the degree of mecha-

Table 12.3. Mean household and per capita income by farm size, mechanization class, and season in 8 villages of Cabanatuan and Guimba, Nueva Ecija, 1979 wet season and 1980 dry season.¹¹

Farm size class	Income (P)					
	Nonmechanized (animal)		Partially mechanized		Fully mechanized	
	Wet season	Dry- season	Wet season	Dry season	Wet season	Dry season
Below 1.00 ha						
Household income	1,470	1,868	1,320	2,225	962	1,970
Per capita income	280	308	226	348	262	515
1.00-2.49 ha						
Household income	883	3,150	2,695	4,825	2,417	4,256
Per capita income	167	542	468	791	450	795
2.50 ha and larger						
Household income	2,320	3,748	4,844	10,847	5,336	9,172
Per capita income	371	576	744	1,298	840	1,562

The problem of affordable machinery can also be seen in Japan, Western Europe, and the U.S. High farm prices have provided Japanese farmers with greater tractor power per unit of cultivated land than farmers in any other major country. Western Europe's high farm subsidies have resulted in a proliferation of specialized agricultural machines and a tractor power intensity greater than that of the U.S., though less than that of Japan. The U.S. has large farm tractors for large farms, but horsepower per cultivated area is less than that of Western Europe because the prices U.S. farmers receive for their products are lower.

12.5 Mechanization and quality of life

Women and children who work in the fields are employed, but at what cost? Children in the fields are not in school and may be condemned to lives of menial labor. Women age prematurely by laboring in the fields as well as performing the housework their societies demand of them. Is the use of machinery to alleviate such conditions socially undesirable?

Young people living on farms in LDCs are no longer cut off from other parts of the world. Schools, radio, television, and cassette players remind them that life can be more than back-breaking work and drudgery. With this in mind, they go to Lima, Manila, Dhaka, and other cities and add to urban congestion.

Farm mechanization in LDCs is inevitable. As other elements—high-yielding varieties, fertilization, pest control, prices—of the agricultural production system evolve, so will mechanization. In one area it will be a change from the hoe to the animal- or tractor-drawn plow. In another it will be from a water buffalo to a pedestrian tractor. In still another it will be from 2-wheel- to 4-wheel-drive farm tractors and 4-row to 12-row planters. Agricultural mechanization helps farm families reduce their hours of hard labor or enlarge their scope of farming. These desirable goals on the part of the farmer, however, may not always coincide with government policies to put landless laborers to work. A farmer may be willing to buy a machine to reduce drudgery for his family, but not for hired labor.

Economists may have a measurement problem when attempting to evaluate the overall benefit of mechanization, since one of the main benefits is reduced drudgery. If benefits are high, and economic analysis fails to include them, the

analysis may wrongly conclude that the farmer made a poor investment. In temperate zones, storeowners and office workers can drive to work in automobiles with power steering. They work in air-conditioned comfort in summer and heated offices in winter. Why should the farm family in the same region not purchase a tractor with power steering and an enclosed cab equipped with air-conditioning and heating for their "office on wheels"?

The social consequences of mechanization are complex. What appear to be perverse decisions by farmers to use inappropriate machines may well be the result of skewed government policies such as overvalued exchange rates, subsidized credit, and excessive tariff protection. Misplaced investment in agricultural machinery occurs in both developed and developing countries.

In general, mechanization reduces employment in agriculture, although some of the displaced workers will find employment in factories producing the new machines and agricultural technology.

Where the growing season is limited and a labor shortage is inevitable, or where specific problems such as difficult tillage exist, mechanization can increase yields. However, even on intensively cultivated farms blessed with good soil, water, growing conditions, and labor, mechanization will not necessarily increase crop yield.

An economy of scale appears to exist in that larger farms can increase income by increasing mechanization—up to a point. Smaller farms, on the other hand, may be able to obtain some of the economy of scale by utilizing custom hire services.

Throughout the 20th century, the mechanization of agriculture has continued to develop. As people seek less arduous lives and the demand for food grows, mechanization will play an increasingly important role in agriculture.

REFERENCES CITED

1. Duff J B (1986) Some consequences of agricultural mechanization in the Philippines, Thailand, and Indonesia. Pages 59-84 *in* Small farm equipment for developing countries. International Rice Research Institute, P.O. Box 933, Manila, Philippines.
2. *Ibid.*, p. 69.
3. *Ibid.*, p. 71.

4. Ahammed C S, Herdt R W (1985) A general equilibrium analysis of the effects of rice mechanization in the Philippines. Modelling the impact of small farm mechanization. Philippine Institute for Development Studies Monog. Ser. 5. p. 58-68. Manila.
5. Duff J B (1986) Changes in small-farm rice threshing technology in Thailand and the Philippines. IRRI Res. Pap. Ser. 120.
6. Ibid., p. 11.
7. Shields D (1985) The impact of mechanization on agricultural production in selected villages of Nueva Ecija. J. Philipp. Dev. 12(1):182-197.
8. Ibid., p. 193
9. Pingali P, Bigot Y, Binswager H P (1987) Agricultural mechanization and the evolution of farming systems in sub-Saharan Africa. Johns Hopkins University Press, Baltimore, Madison. p. 110-111.
10. Lim P C (1985) Effects of agricultural mechanization on farm income patterns. J. Phillip. Dev. 12(1):198-206.
11. Ibid., p. 205.
12. Gee-Clough D (1985) Affordable technology. FFTC Extension Bull. 222. Taipei.
13. Ibid., p. 24.

BIBLIOGRAPHY

- Boyce J K, Hartmann B (1981) Hunger in a fertile land. Food and Agriculture Organization of the United Nations, Rome. p. 32-35.
- Herdt R W (1983) Perspective issues and evidence on rice farm mechanization in developing countries. Pages 111-147 *in* Farm mechanization in Asia. Asian Productivity Organization. Tokyo.
- Herdt R W, Palacpac A C (1983) World rice facts and trends. International Rice Research Institute, P.O. Box 933, Manila, Philippines.
- Stavis B (1978) The politics of agricultural mechanization in China. Cornell University Press, Ithaca, NY.

13 Machinery economics

Before purchasing an agricultural machine, it is prudent to determine its economic viability. Frequently, owners of costly farm machinery consider renting the equipment to their neighbors to help offset the expense. Knowing the fixed and variable costs of machinery used for custom work is necessary prior to quoting rental rates. This chapter describes how to estimate machine capacity, area worked, available time, fixed costs, and variable costs.

13.1 Estimating the cost of field machinery

A machine's cost per hour worked is greatly influenced by its usage. The annual hours of use of some tractors can be determined by reading the hour meter. For most machines, however, the annual hours of use must be calculated by dividing the area worked by the machine's *effective capacity* (EC). Effective capacity equals the theoretical capacity multiplied by the field efficiency. Theoretical capacity is the machine's capacity, working 100% of the time. Field efficiency accounts for efficiency lost while attaching wagons, turning, filling fertilizer hoppers, emptying grain tanks, slowing down over rough terrain, stopping for tea break, and so on.

$$\text{EC (ha/h)} = \frac{\text{Width (m)} \times \text{speed (km/h)} \times \text{field efficiency (decimal)}}{10}$$

or

302 MACHINERY ECONOMICS

$$\text{EC (acres/h)} = \frac{\text{Width (ft) x speed (mph) x field efficiency (decimal)}}{8.25}$$

For example, a 1.7-m reaper traveling at 5 km/h at a field efficiency of 60% has an EC of

$$\frac{1.7 \text{ m} \times 5 \text{ km/h} \times 0.60}{10} = 0.5 \text{ ha/h}$$

Normal speeds and efficiencies of field machinery are shown in Table 13.1.

Table 13.1. Field machinery data.

Machine	Estimated life (h)	Repair group	Depreciation group	Field efficiency
Anhydrous ammonia applicator	1,200	6	C	.60 - .75
Baler with engine	2,500	3	D	.60 - .85
Baler, PTO	2,500	4	D	.60 - .85
Baler, large round	2,500	4	D	.60 - .85
Chisel plow	2,500	7	C	.70 - .90
Combine, PTO	2,000	5	B	.65 - .80
Combine, self-propelled	2,000	3	B	.65 - .80
Cultipacker	2,500	7	C	.70 - .90
Cultivators, seeder, pedestrian	1,200	3	C	.80 - .90
Cultivator, field	2,500	7	C	.70 - .90
Cultivator, row crop	2,500	7	C	.70 - .90
Disk plow	2,500	7	C	.70 - .90
Fertilizer equipment	1,200	6	C	.60 - .75
Flail harvester	2,000	4	C	.50 - .75
Forage blower	2,000	4	D	-
Forage harvester, pull-type	2,000	4	D	.50 - .75
Forage harvester, self-propelled	2,000	3	D	.50 - .85
Grain drill	1,200	5	C	.50 - .85
Harrow, single disk	2,500	7	C	.70 - .90
Harrow, tandem disk	2,500	7	C	.70 - .90
Harrow, heavy tandem disk	2,500	7	C	.70 - .90
Harrow, spring-tooth	2,500	7	C	.70 - .90
Harrow, spike-tooth	2,500	7	C	.70 - .90
Land plane	2,500	3	C	-
Land roller	3,500	7	B	.70 - .90
Loader, front-end	2,500	3	C	-

Table 13.1. continued.

Machine	Estimated life (h)	Repair group	Depreciation group	Field efficiency
Maize head	2,000	5	C	—
Maize picker	2,000	4	C	.60 - .80
Maize planter	1,200	5	C	.50 - .85
Manure spreader, beaters	2,500	3	C	.60 - .90
Manure spreader, flail	2,000	3	C	.60 - .90
Manure spreader, liquid	2,500	3	C	.60 - .90
Middle breaker	2,500	7	C	.70 - .90
Moldboard plow	2,500	7	C	.70 - .90
Mower, cutterbar	2,000	7	C	.75 - .85
Mower, flail	2,000	4	C	.80 - .90
Mower-rotary (horizontal blade)	2,000	3	C	.80 - .90
Mower-conditioner	2,500	5	B	.55 - .85
Potato harvester	2,500	4	C	.60 - .80
Rake, side delivery	2,500	7	C	.70 - .90
Rod weeder	2,500	7	C	.70 - .90
Rotary hoe	2,500	7	C	.70 - .85
Standby power unit	12,000	2	A	—
Sprayer, mounted	1,200	5	C	.50 - .80
Sprayer, self-propelled	2,000	4	D	.50 - .80
Subsoiler	2,500	7	C	.70 - .90
Swather, self-propelled	2,500	5	B	.60 - .85
Stalk cutter	2,000	3	C	.70 - .90
Tractor, pedestrian	1,200	3	A	—
Tractor, 2-wheel drive	12,000	2	A	—
Tractor, 4-wheel drive	12,000	1	A	—
Tractor, tracklayer	12,000	1	A	—
Truck, farm	2,000	4	C	—
Truck, pickup	2,000	3	C	—
Wagon box	5,000	5	B	—

Effective capacity is used to calculate a machine's annual hours of use. For example, if a farmer uses a reaper with an EC of 0.5 ha/h to cut 40 ha of rice per year, the annual hours of use = $40 \text{ ha} \div 0.5 \text{ ha/h} = 80 \text{ h/yr}$. For crops such as grasses that are harvested several times per year, or for a field plowed several times per year, the area worked by the machine is the area traversed by the machine in 1 yr. For example, if a mower cuts a 20-ha field of alfalfa 3 times a year, the mower cuts 60 ha/yr.

The total cost of operating an agricultural machine consists of *fixed costs* (sometimes called ownership costs) and

variable costs (sometimes called operational costs). The variable costs—fuel and lubrication, repairs, labor—depend on the use of the machine, while fixed costs—depreciation, interest on investment, insurance, shelter—are independent of machine usage.

Depreciation occurs as new technology and practices make older machines less desirable. As machines age, the likelihood of breakdown increases. Depreciation can be calculated by trade-in value. The actual value of a machine (and thus its depreciation) is unknown until it is sold second-hand or abandoned. Depreciation can usually be estimated with general knowledge of used equipment prices.¹ Farm machines do not all depreciate at the same rate. To help estimate depreciation, the machines are classified into four general depreciation groups: A, B, C, and D. Group A machines depreciate at the slowest rate and Group D, the fastest. A hay baler (Group D) depreciates faster than a tractor (Group A).

Based on the interpretation of such data,² Table 13.2 lists the average values for 4 groups of machines up to 15 yr old. The estimated values are in U.S. dollars per \$1,000 of initial list price.

Insurance, shelter for the machine, and interest on the investment are the remaining fixed costs. Interest is a consideration regardless of whether or not the farmer borrows money from the bank. Even if the farmer pays cash for the machine, interest is an expense in that the capital could otherwise be drawing interest on the money. In Table 13.3, interest at 10%, insurance, and shelter are lumped together as an annual cost equal to 12% of the depreciated value of the machine. In Table 13.4, interest at 20%, insurance, and shelter are lumped together as an annual cost equal to 22% of the depreciated value of the machine.

Table 13.2. On-farm value of agricultural machines in U.S. dollars per \$1,000 of initial list price.

Depreciation group	On-farm value (US\$) at a given age in yr														
	1	2	3	4	5	6	7	8	9	10	11	12	13	14	15
A	626	576	530	487	448	412	379	349	321	295	272	250	230	212	195
B	566	501	444	393	347	307	272	241	213	189	167	148	131	116	102
C	531	470	416	368	326	228	255	226	200	177	156	139	123	108	96
D	496	439	388	343	304	269	238	211	186	165	146	129	114	101	90

Table 13.3. Average annual fixed cost in U.S. dollars per \$1,000 of initial list price @ 12% of average value.^a

Depreciation group	Cost (\$) at a given age in yr														
	1	2	3	4	5	6	7	8	9	10	11	12	13	14	15
A	366	244	200	176	160	148	138	130	123	117	112	107	102	98	94
B	422	275	222	192	171	156	144	133	125	117	110	104	99	94	89
C	455	288	228	195	172	156	143	133	124	116	109	103	97	92	88
D	488	300	234	197	174	156	143	132	122	114	107	101	96	91	86

^a Based on depreciation from Table 13.2 plus 12% (10% interest + 1.5% shelter + 0.5% insurance) of the average value during the year. It is assumed that a new machine is purchased at 10% below list price.

Table 13.4. Average annual fixed cost in U.S. dollars per \$1,000 of initial list price @ 22% of average value.^a

Depreciation group	Cost (\$) at a given age in yr														
	1	2	3	4	5	6	7	8	9	10	11	12	13	14	15
A	442	312	264	237	218	203	191	181	172	164	157	151	145	139	134
B	495	339	280	242	222	203	189	176	165	155	147	139	132	126	120
C	526	349	283	246	220	210	184	171	160	151	142	134	128	121	116
D	558	359	286	246	219	199	183	170	158	148	140	132	125	119	113

^a Based on depreciation from Table 13.2 plus 22% (20% interest + 1.5% shelter + 0.5% insurance) of the average value during the year. It is assumed that a new machine is purchased at 10% below list price.

Depreciation is added to the other fixed costs for four machinery groups and listed in Table 13.3 as accumulated fixed costs per \$1,000 of initial list price up to 15 yr. The prices cited in Table 13.3 reflect a 10% discount from the initial list price, since most agricultural machines are not sold at advertised retail prices. For example, it is assumed that a machine in Group A with a list price of \$1,000 was purchased for \$900 at a 10% discount. One year later the machine had depreciated to a value of \$626 (see Table 13.2). During its first year, therefore, the machine's average value was \$763. That is, it was worth \$700 brand new and \$626 at the end of the year, so its average value during the year was \$763. The total fixed cost for the machine at the end of the first year is computed as follows:

$$\begin{aligned}
 \text{First year depreciation} &= \$900 - \$626 &&= \$274 \\
 \text{First year interest, shelter, insurance} &= 12\% \times \$763 &&= \underline{92} \\
 \text{Accumulated total fixed cost} &&&= \$366
 \end{aligned}$$

Table 13.3 was compiled using the above calculations. It assumes an interest rate of 10%; Table 13.4 assumes 20%.

Fuel costs are probably the simplest variable costs to compute. Most farmers keep their fuel receipts. Tractor fuel consumption can be estimated from the following equations, which are based on average varying power and fuel consumption runs from Nebraska Tractor Test reports.

Average fuel consumption can be estimated³:

Gasoline (liters/h) = 0.227 x maximum PTO hp

Diesel (liters/h) = 0.166 x maximum PTO hp

LPG (liters/h) = 0.272 x maximum PTO hp

or

Gasoline (US gal/h) = 0.060 x maximum PTO hp

Diesel (US gal/h) = 0.044 x maximum PTO hp

LPG (US gal/h) = 0.072 x maximum PTO hp

The above estimates are for average fuel consumption per hour. To estimate fuel consumption under maximum power conditions such as heavy plowing, multiply the above estimates by 1.5. For example, if a 100-hp diesel tractor consumes an average of 17 liters/h, it uses 1.5 times the average under maximum power conditions, or 25 liters/h.

Oil, grease, and filters are lumped together under lubrication, which averages 15% the fuel cost. Lubrication is considered in the cost estimates by using the following equation:

$$\text{Fuel and lubrication cost} = \text{___ max PTO hp} \times \text{___ factor} \\ \times \text{\$/liter} = \text{\$/h}$$

The factors are 0.261 for gasoline, 0.191 for diesel, and 0.313 for LPG. Factors for U.S. gallons are listed on the English unit worksheets.

Repair costs are highly variable and depend largely on the quality of machinery management. The terrain, soil, and type of crop also dramatically affect repair costs. All variable costs depend on the total hours of machine use. Agricultural field machines are classified into seven groups for estimating repair costs.⁴ The estimated life and repair groups for various machines are listed in Table 13.1. The repair curves (Figs. 13.1-13.7) provide estimates of repair costs at any point in the life of a machine. The costs are shown as cumulative costs, that is, the total repair costs from the day the machine was delivered from the factory. The curves provide repair cost

estimates for farmers who have not developed their own repair cost guides. The repair cost equations on which the curves are based were developed from surveys in the mid-western U.S.⁵

Figures 13.1-13.7 differ primarily in the rate of repair cost increase in relation to cumulative hours of use.

If a repair group recommended in Table 13.1 does not seem to fit a situation, another repair curve may be used. For example, if the recommended repair curve, repair group 3, for a self-propelled combine seems too low, the estimated repair cost can be increased by using a steeper curve, such as repair group 4. The estimated repair cost can also be altered by changing the estimated hours of life of the machine. Increasing the estimated hours of life will decrease the repair cost; decreasing the estimated hours of life will increase the estimated repair cost. If operators are not properly trained in the use of machinery, if maintenance is poor, or if spare parts are difficult to obtain, it is a good idea to lower the estimated hours of life in order to increase hourly repair costs. This is often the case in LDCs.

13.1. Accumulated cost of repairs for repair group 1.

The cost of operating a machine can be estimated by following the steps in the worksheet for metric units (Table 13.5) or that for English units (Table 13.6).

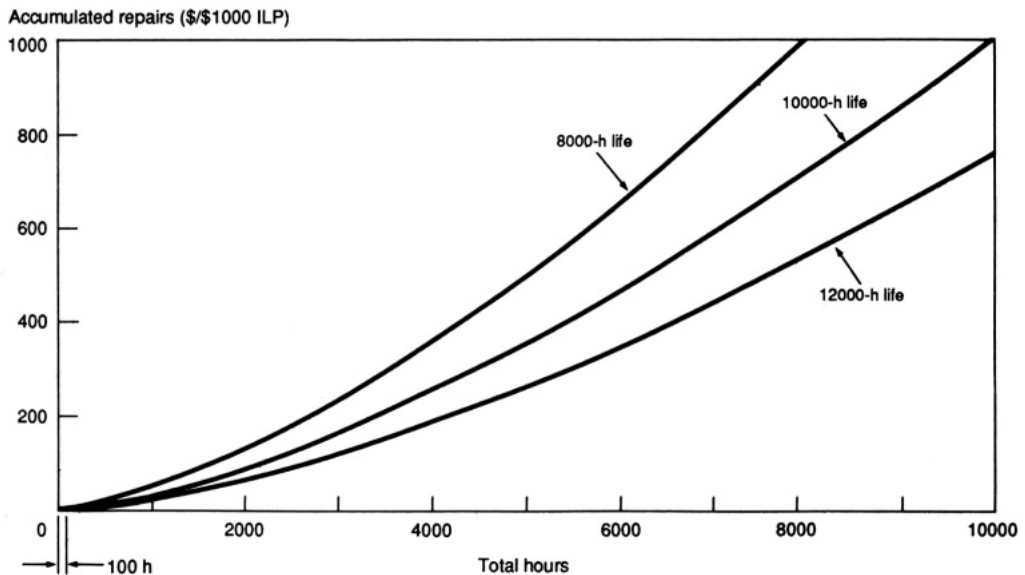

$$\text{Repair } \$/\$1000 \text{ ILP} = (100 \times \text{hours} / \text{estimated hours life})^{1.5}$$

Accumulated repairs (\$/\$1000 ILP)

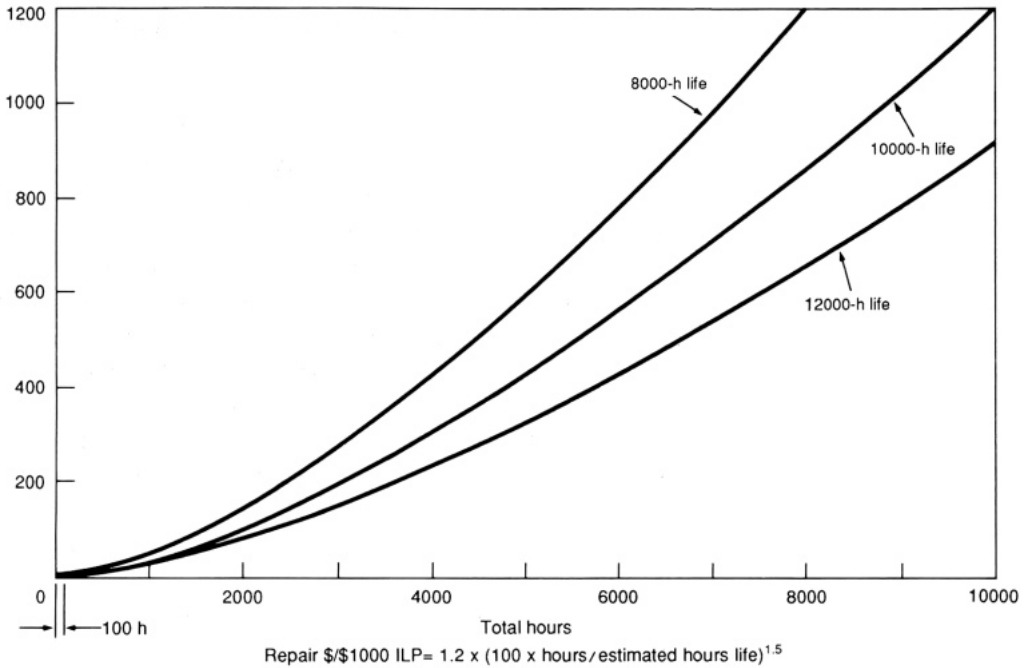

13.2. Accumulated cost of repairs for repair group 2.

13.3. Accumulated cost of repairs for repair group 3.

Accumulated repairs (\$/\$1000 ILP)

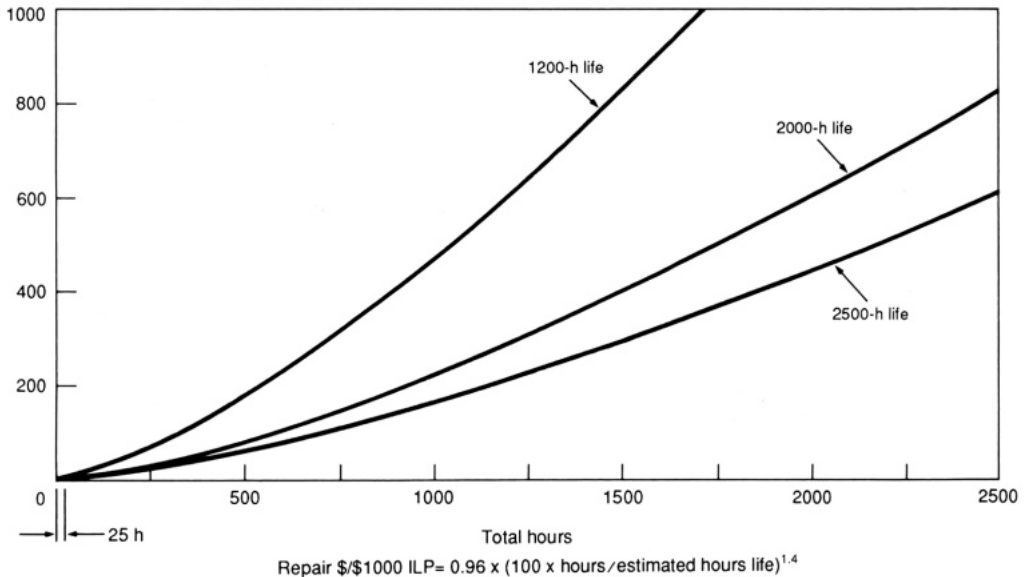

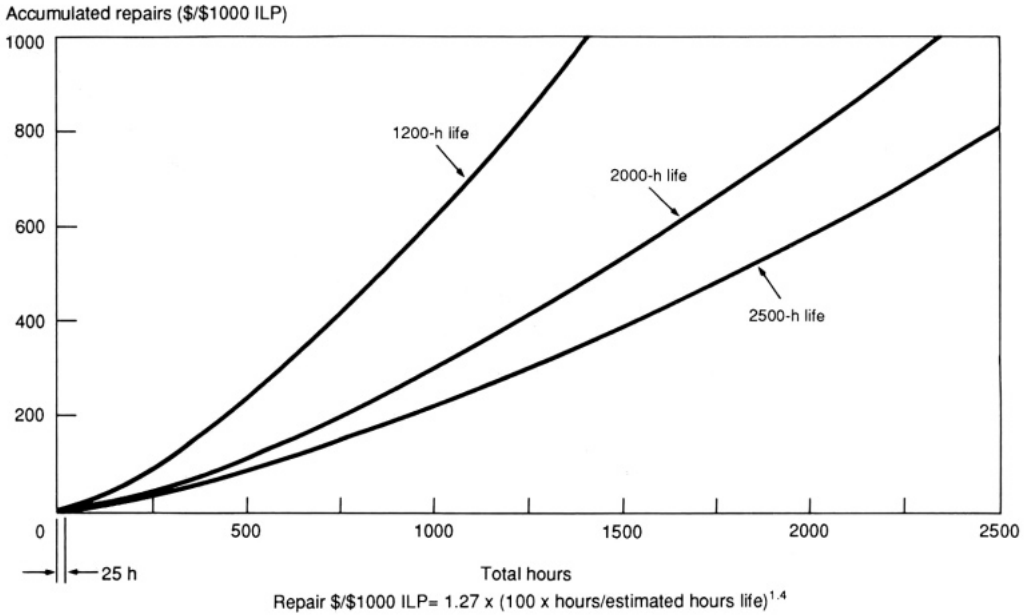

13.4. Accumulated cost of repairs for repair group 4.

13.5. Accumulated cost of repairs for repair group 5.

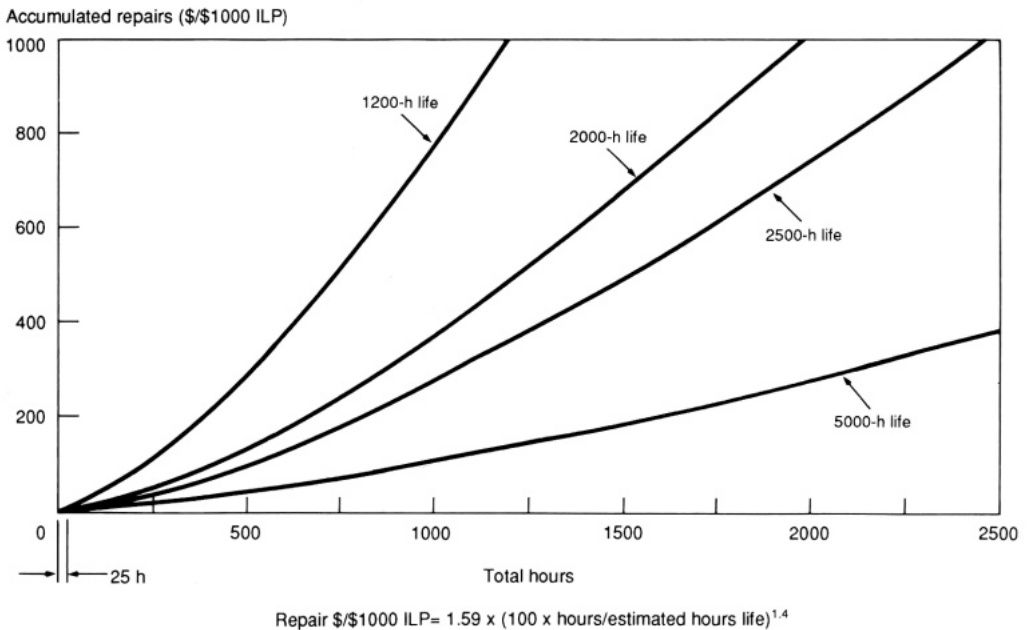

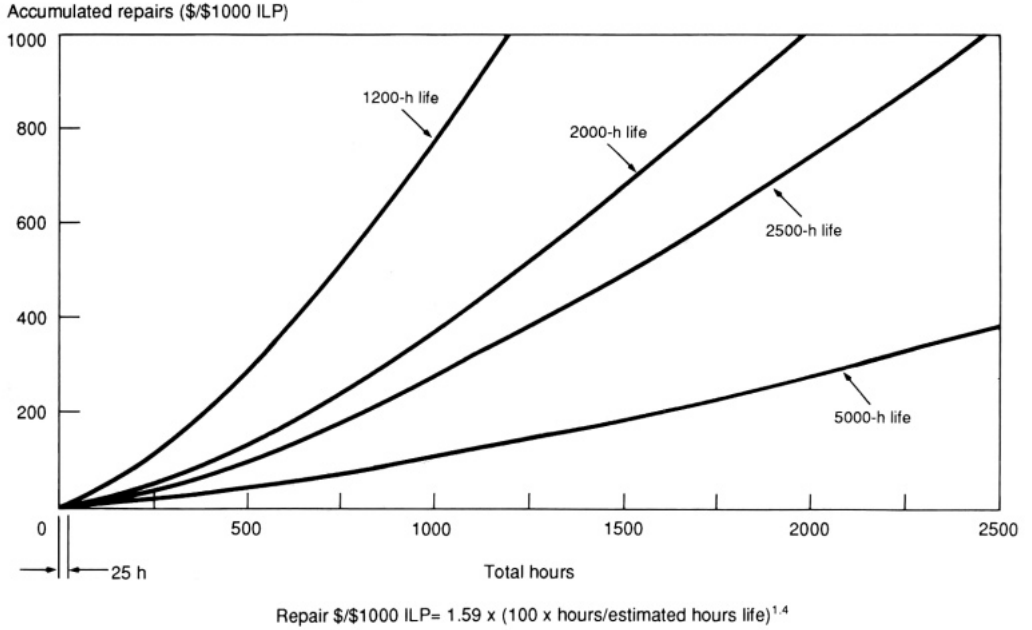

13.6. Accumulated cost of repairs for repair group 6 (above).

13.7. Accumulated cost of repairs for repair group 7 (below).

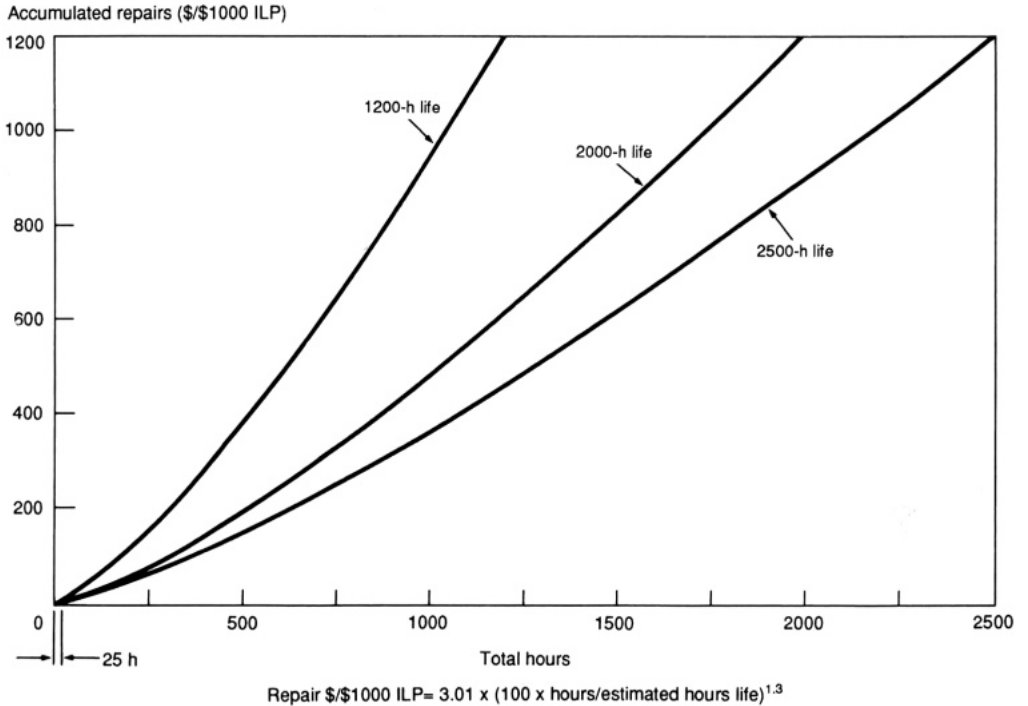

Table 13.5. Field machinery cost worksheet, metric units.

Machine	HP	New machine initial list price	Estimated life (h) ^a	Repair group ^a	Depreciation group ^a
(1) Hectares to work per year				_____	_____ ha
(2) Field speed				_____	_____ km/h
(3) Width of effective swath				_____	_____ m
(4) Field efficiency (your value or estimate from Table 13.1)				_____	_____
(5) Effective capacity = (line 2) x (line 3) x (line 4) ÷ 10 = _____ x _____ x _____ ÷ 10				= _____	= _____ ha/h
(6) Annual hours of operation = (line 1) ÷ (line 5) = _____ ÷ _____					= _____ h/Yr
FIXED COSTS					
(7) Expected age at trade-in				_____	_____ yr
(8) Average annual fixed cost per \$1000 initial list price (ilp) Use Table 13.3 (10% interest) or Table 13.4 (20% interest)				_____	\$ _____ /\$1000 ilp
(9) Average annual fixed cost = (line 8) x (ilp/1000) = _____ x _____ /1000				_____	\$ _____ /yr
(10) Fixed cost per hectare = line 9 ÷ line 1 = \$ _____ ÷ _____					= \$ _____ /ha
(11) Fixed cost per hour = line 9 ÷ line 6 = \$ _____ ÷ _____					= \$ _____ /h
VARIABLE (OPERATING) COSTS					
Repairs Age and hours on machine purchased by you				_____	\$ _____ yr _____ h
(12) Total accumulated repair hours at trade-in = line 6 x line 7 = _____ h/yr x _____ yr					= _____ h
(13) Repair cost factor from appropriate repair group (from Figures 13.1-13.7)					= \$ _____ /1000 lip
(14) Accumulated repair cost = ilp ÷ 1000 x line 13 = \$ _____ 1,000 x _____					= \$ _____
(15) Annual average repair cost = line 14 ÷ line 7 = \$ _____ ÷ _____					= \$ _____ /yr
(16) Average repair cost per hectare = line 15 ÷ line 1 = _____ ÷ _____					= _____ /ha
(17) Average repair cost per hour = line 15 ÷ line 6 = _____ ÷ _____					= \$ _____ /h
Fuel and lube					
(18) Fuel and lube = tractor or engine hp x F & L factor ^c x fuel cost = _____ hp x _____ F&L factor x \$ _____ /liter					\$ _____ /h
Labor					
(19) Labor cost = number of operators x hourly rate = _____ x \$ _____ /h					= \$ _____ /h
Tractor cost for towed implement					
(20) Tractor hourly cost					= \$ _____ /h
Total operating costs:					
(21) Operating cost per hour = repairs (17) + fuel (18) + labor (19) + tractor (20) = _____ + _____ + _____					= \$ _____ /h
(22) Operating cost per ha = line 21 ÷ line 5 = _____ ÷ _____					= \$ _____ /ha
TOTAL COST					
(23) Total cost per hour = operating cost (line 21) + fixed cost (line 11) = \$ _____ /h + \$ _____ h					= \$ _____ /h
(24) Total cost per hectare = operating cost (line 22) + fixed cost (line 10) = \$ _____ /ha + \$ _____ ha					= \$ _____ /ha

Obtain from Table 13.1 Field machinery data.

Fuel and lube factor, gasoline = 0.261, diesel = 0.191. LPG = 0.313.

Table 13.6. Field machinery cost worksheet, English units.

Machine	HP	New machine initial list price	Estimated life (h) ^a	Repair group ^a	Depreciation group ^a
(1) Acres to work per year				_____	ac
(2) Field speed				_____	mph
(3) Width of effective swath				_____	ft
(4) Field efficiency (your value or estimate from Table 13.1)				_____	
(5) Effective capacity = (line 2) x (line 3) x (line 4) ÷ 8.25					
= _____ x _____ x _____ x _____ ÷ 8.25				= _____	ac/h
(6) Annual hours of operation = (line 1) + (line 5) = _____ ÷ _____				= _____	h/yr
FIXED COSTS					
(7) Expected age at trade-in				_____	yr
(8) Average annual fixed cost per \$1000 initial list price (ilp)					
Use Table 13.3 (10% interest) or Table 13.4 (20% interest)				\$ _____	/ \$1000 ilp
(9) Average annual fixed cost = (line 8) x (ilp/1000)					
= _____ x _____ / 1000				= \$ _____	/yr
(10) Fixed cost per acre = line 9 ÷ line 1 = \$ _____ ÷ _____				= \$ _____	/ac
(11) Fixed cost per hour = line 9 ÷ line 6 = \$ _____ ÷ _____				= \$ _____	/h
VARIABLE (OPERATING) COSTS					
Repairs Age and hours on machine purchased by you					
				= _____	yr h
(12) Total accumulated repair hours at trade-in = line 6 x line 7					
= _____ h/yr x _____ yr				= _____	h
(13) Repair cost factor from appropriate repair group (from Figures 13.1-13.7)				= \$ _____	/1000 ilp
(14) Accumulated repair cost = ilp ÷ 1000 x line 13					
= \$ _____ ÷ 1,000 x _____				= \$ _____	
(15) Annual average repair cost = line 14 ÷ line 7 = \$ _____ ÷ _____ yr				= \$ _____	/yr
(16) Average repair cost per acre = line 15 ÷ line 1 = _____ ÷ _____				= \$ _____	/ac
(17) Average repair cost per hour = line 15 ÷ line 6 = _____ ÷ _____				= \$ _____	/h
Fuel and lube					
(18) Fuel and lube = tractor or engine hp x F & L factor ^b x fuel cost					
= _____ hp x _____ F & L factor x \$ _____ /US gal				= \$ _____	/h
Labor					
(19) Labor cost = number of operators x hourly rate = _____ x \$ _____ /h				= \$ _____	/h
Tractor cost for towed implement					
(20) Tractor hourly cost				= \$ _____	/h
Total operating costs:					
(21) Operating cost per hour = repairs (17) + fuel (18) + labor (19) + tractor (20)					
= _____ + _____ + _____ + _____ + _____				= \$ _____	/h
(22) Operating cost per acre = line 21 ÷ line 5 = _____ ÷ _____				= \$ _____	/ac
TOTAL COST					
(23) Total cost per hour = operating cost (line 21) + fixed cost (line 11)					
= \$ _____ /h + \$ _____ /h				= \$ _____	/h
(24) Total cost per acre = operating cost (line 22) + fixed cost (line 10)					
= \$ _____ /ac + \$ _____ /ac				= \$ _____	/ac

^a Obtain from Table 13.1 Field machinery data.

^b Fuel and lube factor: gasoline = 0.069, diesel = 0.050, LPG = 0.083.

13.2 Multipurpose machines

To some extent, a machine such as a combine is multipurpose; with only a change of the header and some adjustments to cylinder speed and concave clearances, the combine can be changed from a machine to harvest small grain to one that can harvest maize. Farmers have generally accepted this type of flexibility in a machine.

Engineers and economists have pursued the goal of developing a basic machine to which most of a farmer's implements can be added. For the engineer, the tool-carrier concept holds forth the promise of an integrated line of implements designed to fit a common tool carrier and thus reduce the number of individual parts that must be designed, manufactured, and carried in stock. For the economist, the tool-carrier concept has the promise of the farmer purchasing fewer individual machines, thus investing less capital in agricultural equipment. Although the goal has been pursued for at least 50 yr, the concept of a common tool carrier instead of individual machines has not been well accepted by farmers.

The farm tractor is used as a tool carrier. Because of the world standard three-point hitch and PTO, implements from many manufacturers can be attached to a farm tractor quickly and easily. The ease and the rapidity of attaching implements make the farm tractor a tool carrier for the simpler implements. However, if there is need for many hours of work for a particular implement, the tendency is to use a specialized, self-propelled machine. For example, to cut a haycrop, a mower can be attached to a tractor or a mower-conditioner pulled by a tractor; however, if a large amount of mowing is required, the farmer in many markets will probably purchase a self-propelled mower-conditioner or windrower.

In the U.S. in the 1940s, Minneapolis MolineTM developed and marketed a self-propelled tractor chassis on which fitted a grain combine, maize picker, maize picker-sheller, forage harvester, snow blower, and several other implements so that all could be self-propelled. In North America in the 1950s, FergusonTM had a line of implements including a forage harvester, baler, and combine that mounted on the FergusonTM tractor to make these implements self-propelled machines. For the most part, farmers did not accept this concept, in that most Minneapolis MolineTM units were used by farmers as single-purpose self-propelled machines, and FergusonTM sales were so low that the models were

discontinued. About 1955, Jean Nolle applied the tool-carrier concept to animal-drawn implements with his development of a wheeled tool carrier called the Polyculteur, and about 3 yr later the National Institute of Agricultural Engineering in Great Britain began work on an animal-drawn toolbar. Many agricultural machinery research organizations in the tropics and semitropics followed with their own designs. Probably the greatest effort was expended by ICRISAT, which began a decade of research on bullock-drawn wheeled tool carriers in 1974.

Animal-drawn wheeled tool carriers have not been accepted by farmers, although about 10,000 have been made in the world and sold at subsidized prices over the past 30 yr.⁶ The designs have not been accepted because they are too costly for the benefits derived; the tool carrier must be made heavy enough to support the tool with the greatest draft so that the tool carrier is overdesigned for lighter implements. On the economic side, the tool carriers must compete with native ards, sowing of seed by hand, low grain prices, and farmers who have little capital. The animal-drawn tool carriers performed well technically, but because they and their implements were more sophisticated and costlier than the implements or practices they were to replace, and because they did not increase yield or reduce costs, they were not accepted.

13.3 Examples of estimating the cost of field machinery

1. A farmer purchased a new pull-type hay baler for making small rectangular bales, powered by a 20-hp gasoline engine. He paid 10% below the list price of \$ 10,000. Since he makes 3 cuttings annually on his 50 ha of haycrop, the machine will bale 150 ha/yr. He likes to use late model machines, so he intends to trade the baler after 5 yr. While baling, he drives at 8 km/h and picks up windrows made from 3-m swaths. Field efficiency is 70%. His records show that the tractor to pull the baler costs \$5.00/h. The driver is paid \$7.00/h. No labor other than the tractor driver is required. Gasoline costs \$0.25/liter. The interest rate is 10%

What is the average hourly cost of operation, not including the cost of baler twine? What is the estimated value of the machine at the end of 3 yr? The completed worksheet is shown in Table 13.7.

Table 13.7. Worksheet example 1, metric units.

Machine	HP	New machine Initial list price	Estimated life (h)	Repair group	Depreciation group
Pull type hay bailer	20	\$10,000	2500	3	D
(1) Hectares to work per year					<u>150</u> ha
(2) Field speed					<u>8</u> km/h
(3) Width of effective swath					<u>3</u> m
(4) Field efficiency					<u>.70</u>
(5) Effective capacity = (line 2) x (line 3) x (line 4) ÷ 10 = <u>8</u> x <u>3</u> x <u>.70</u> ÷ 10				=	<u>1.68</u> ha/h
(6) Annual hours of operation = (line 1) ÷ (line 5) = <u>150</u> ÷ 1.68				=	<u>89</u> h/yr
FIXED COSTS					
(7) Expected age at trade-in					<u>5</u> Yr
(8) Average annual fixed cost per \$1 000 initial list price (ilp) Use Table 13.3 (10% interest) or Table 13.4 (20% Interest)					<u>\$174</u> /\$1000 ilp
(9) Average annual fixed cost = (line 8) x (ilp/1000) = <u>174</u> x 10,000 /1000				=	<u>\$1,740</u> yr
(10) Fixed cost per hectare = line 9 ÷ line 1 = \$ <u>1,740</u> ÷ 50				=	<u>\$11.60</u> /ha
(11) Fixed cost per hour = line 9 ÷ line 6 = \$ <u>1,740</u> ÷ 89				=	<u>\$19.55</u> /h
VARIABLE (OPERATING) COSTS					
Repairs Age and hours on machine purchased by you				=	<u>0</u> yr <u>0</u> h
(12) Total accumulated repair hours at trade-in = line 6 x line 7 = <u>89</u> h/yr x <u>5</u> yr				=	<u>445</u> h
(13) Repair cost factor				=	<u>\$54</u> /1000 ilp
(14) Accumulated repair cost = ilp ÷ 1000 x line 13 = 5 <u>10,000</u> ÷ 1,000 x 54				=	<u>\$540</u>
(15) Annual average repair cost = line 14 ÷ line 7 = \$ <u>540</u> ÷ <u>5</u> yr				=	<u>\$108</u> /yr
(16) Average repair cost per hectare = line 15 ÷ line 1 = <u>108</u> ÷ <u>150</u>				=	<u>\$0.72</u> /ha
(17) Average repair cost per hour = line 15 ÷ line 6 = <u>108</u> ÷ <u>89</u>				=	<u>\$1.21</u> /h
Fuel and lube					
(18) Fuel and lube = tractor or engine hp x F & L factor x fuel cost = <u>20</u> hp x <u>.261</u> F & L factor x \$ <u>0.25</u> /liter				=	<u>\$1.30</u> /h
Labor					
(19) Labor cost = number of operators x hourly rate = <u>1</u> x \$ <u>7.00</u> /h				=	<u>\$7.00</u> /h
Tractor cost for towed implement					
(20) Tractor hourly cost				=	<u>\$5.00</u> /h
Total operating costs:					
(21) Operating cost per hour = repairs (17) + fuel (18) + labor (19) + tractor (20) = <u>1.21</u> + 1.30 + <u>7.00</u> + <u>5.00</u>				=	<u>\$14.51</u> /h
(22) Operating cost per ha = line 21 ÷ line 5 = 14.51 ÷ 1.68				=	<u>\$8.64</u> /ha
TOTAL COST					
(23) Total cost per hour = operating cost (line 21) + fixed cost (line 11) = \$ <u>14.51</u> /h + \$ <u>19.55</u> /h				=	<u>\$34.06</u> /h
(24) Total cost per hectare = operating cost (line 22) - fixed cost (line 10) = \$ <u>8.64</u> /ha + \$ <u>11.60</u> /ha				=	<u>\$20.24</u> /ha

Table 13.8. Worksheet example 2, English units.

Machine	HP	Newmachine initial list price	Estimated life (h)	Repair group	Depreciation group
2-row pedestrian seeder (Sri Lanka)	-	\$100	1200	3	C
(1) Acres to work per year				<u>20</u> ac	
(2) Fieldspeed				<u>1.6</u> mph	
(3) Width of effective swath				<u>1.3</u> ft	
(4) Field efficiency				<u>.60</u>	
(5) Effective capacity = (line 2) x (line 3) x (line 4) ÷ 8.25 = <u>1.6</u> x <u>1.3</u> x <u>.60</u> ÷ 8.25				= <u>0.15</u> ac/h	
(6) Annual hours of operation = (line 1) + (line 5) = <u>20</u> ÷ 0.15				= <u>133</u> h/yr	
FIXED COSTS					
(7) Expected age at trade-in				8 yr	
(8) Average annual fixed cost per \$1000 initial list price (ilp) Use Table 13.3 (10% interest) or Table 13.4 (20% interest)				<u>\$171</u> /\$1000 ilp	
(9) Average annual fixed cost = (line 8) x (ilp/1000) = <u>171</u> x <u>100/1000</u>				= <u>\$17.10</u> /yr	
(10) Fixed cost per acre = line 9 ÷ line 1 = \$ <u>17.10</u> ÷ <u>20</u>				= <u>\$0.86</u> /ac	
(11) Fixed cost per hour = line 9 ÷ line 6 = \$ <u>17.10</u> ÷ <u>133</u>				= <u>\$0.13</u> /h	
VARIABLE (OPERATING) COSTS					
Repairs Age and hours on machine purchased by you				= <u>0</u> yr <u>0</u> h	
(12) Total accumulated repair hours at trade-in = line 6 x line 7 = <u>133</u> h/yr x <u>8</u> yr				= <u>1064</u> h	
(13) Repair cost factor				- <u>\$510</u> /1000 ilp	
(14) Accumulated repair cost = ilp ÷ 1000 x line 13 = \$ <u>100</u> ÷ 1,000 x <u>510</u>				= <u>\$51</u>	
(15) Annual average repair cost = line 14 ÷ line 7 = \$ <u>51</u> ÷ <u>8</u> yr				= <u>\$6.38</u> /yr	
(16) Average repair cost per acre = line 15 ÷ line 1 = <u>6.38</u> ÷ <u>20</u>				= <u>\$0.32</u> /ac	
(17) Average repair cost per hour = line 15 ÷ line 6 = <u>6.38</u> ÷ <u>133</u>				= <u>\$0.05</u> /h	
Fuel and lube					
(18) Fuel and lube = tractor or engine hp x F & L factor x fuel cost = _____ hp x _____ F & L factor x \$ _____ /US gal				= <u>\$ 0</u> /h	
Labor					
(19) Labor cost = number of operators x hourly rate = <u>1</u> x \$ <u>0.20</u> /h				= <u>\$0.20</u> /h	
Tractor cost for towed implement					
(20) Tractor hourly cost				= <u>\$ 0</u> /h	
Total operating costs:					
(21) Operating cost per hour = repairs (17) + fuel (18) + labor (19) + tractor (20) = <u>.05</u> + <u>0</u> + <u>.20</u> + <u>0</u>				= <u>\$0.25</u> /h	
(22) Operating cost per acre = line 21 ÷ line 5 = <u>.25</u> ÷ <u>.15</u>				= <u>\$1.67</u> /ac	
TOTAL COST					
(23) Total cost per hour = operating cost (line 21) + fixed cost (line 11) = \$ <u>.25</u> /h + \$ <u>.13</u> /h				= <u>\$0.38</u> /h	
(24) Total cost per acre = operating cost (line 22) + fixed cost (line 10) = \$ <u>1.67</u> /ac + \$ <u>.86</u> /ac				= <u>\$2.53</u> /ac	

2. A farmer in Sri Lanka has purchased a new 2-row pedestrian seeder with a list price of \$100 at a 10% discount. The interest rate is 20%. The seeder has an effective swath of 1.3 ft and will be used to plant 20 acres/yr for 8 yr. Speed is 1.6 mph, and field efficiency is 60%. The seeder needs one operator, who is paid \$0.20/h.

What is the fixed cost, operating cost, and total cost per acre? The completed worksheet is shown as Table 13.8.

3. What is the average hourly cost for a compact tractor with a 12-hp gasoline engine over a period of 10 yr? List price is \$3,500. The tractor will be used 600 h/yr on a variety of light to heavy jobs. The tractor can be purchased at 10% below list price. The interest rate is 10%. Fuel costs \$0.50/liter. (Note that on the worksheet, items 1, 2, 3, 4, 5, 10, 16, 22, and 24 do not apply, since they refer to hectares and acres.)

Answer: For 12,000 h estimated life, repair group 2, and depreciation group A, total cost = \$2.49/h, of which \$1.81 is operating cost and \$0.68 is fixed cost.

REFERENCES CITED

1. American Society of Agricultural Engineers (1985) ASAE standards. Agricultural machinery management data. St. Joseph, Michigan. 156 p.
2. Campbell J K (19-8) Selecting field machinery - estimating cost. Agric. Eng. Ext. Bull. 431. Cornell University, Ithaca, New York.
3. Ibid., p. 4.
4. American Society of Agricultural Engineers (1977) ASAE yearbook. St. Joseph, Michigan.
5. Bowers W, Hunt D R (1969) Application of mathematical formulas to repair cost data. ASAE Paper 69-159. American Society of Agricultural Engineers, St. Joseph, Michigan
6. Starkey P (1988) Animal-drawn wheeled toolcarriers: perfected yet rejected—a cautionary tale of development. 131 p. Deutsche Gesellschaft für Technische Zusammenarbeit, Eschborn.

BIBLIOGRAPHY

- Cronk B J, Williams T H, Krismnan P, Kemble L J (1987) Optimal width equations for various tillage implements. ASAE Paper 87-1612 American Society of Agricultural Engineers, St. Joseph, Michigan.
- Rogin L (1931) The introduction of farm machinery in its relation to the productivity of labor in the agriculture of the United States during the nineteenth century. University of California Press, Berkeley, California. [Johnson Reprint Corp., New York 1966]
- Ulloa O T, Esmay M L (1987) Machinery selection model for Mexico. ASAE Paper 87-5521. American Society of Agricultural Engineers. St. Joseph, Michigan.

Abbreviations and acronyms

ASAE = American Society of Agricultural Engineers

CAAMS = Chinese Academy of Agricultural Mechanization Sciences

CDA = controlled droplet application

CIAIT = Centro Internacional de Agricultura Tropical

CIP = International Potato Center

D = draft

DIN = Deutsche Industrie Norm

Dwb = drawbar

EC = effective capacity

f_r = coefficient of rolling friction

FAO = Food and Agriculture Organization

ICRISAT = International Crops Research Institute for the Semi-Arid Tropics

ilp = initial list price

IRRI = International Rice Research Institute

IWC = inches of water column

LDC = less developed country

LER = land equivalent ratio

LPG = liquefied petroleum gas

LSU = Louisiana State University

MC = moisture content

PTO = power-take-off

RH = relative humidity

SAE = Society of Automotive Engineers

SI = Le Système International d'Unités

SP = static pressure

TDN = total digestible nutrients

ULV = ultralow volume (sprayer)

wb = wet basis

Appendices

Appendix A. Metric - English conversions

Non-SI metric unit	x	factor	=	SI metric unit	x	factor	=	non-SI metric unit
Mass								
pound (lb)		453.6		gram (g)		0.002205		lb
pound (lb)		0.4536		kilogram (kg)		2.205		lb
metric ton (t) (2205 lb)		1000		kilogram (kg)		0.001		t
pound/square foot (lb sq ft)		0.4882		gram square centimeter (g/cm ²)		2.048		lb/sq ft
pound/acre (lb/ac)		1.121		kilogram hectare (kg/ha)		0.8922		lb/ac
ounce/US gallon (oz/US gal)		7.491		gram liter (g liter)		0.1335		oz/US gal
pound/US gallon (lb/US gal)		119.9		gram liter (g liter)		0.008344		lb/US gal
Distance								
mil (0.001 in)		0.0254		millimeter (mm)		39.37		mil
inch (in)		25.40		millimeter (mm)		0.03937		in
inch (in)		2.540		centimeter (cm)		0.3937		in
hand		10.16		centimeter (cm)		0.09843		hand
foot (ft)		30.48		centimeter (cm)		0.03281		ft
mile		1.609		kilometer (km)		0.6214		mile
Area								
square inch (sq in)		6.452		square centimeter (cm ²)		0.1550		sq in
square foot (sq ft)		0.093		square meter (m ²)		10.76		sq ft
acre (ac)		4047		square meter (m ²)		0.000247		ac
acre (ac)		0.4047		hectare (ha)		2.471		ac
square mile (sq mile)		259.0		hectare (ha)		0.003861		sq mile
Volume								
cubic inch (cu in)		16.39		cubic meter (m ³)		0.06102		cu in
cubic inch (cu in)		16.39		milliliter (ml)		0.06102		cu in
cubic foot (cu ft)		28.32		liter		0.03531		cu ft
fluid ounce (fluid oz)		29.57		milliliter (ml)		0.03381		fluid oz
pint (pt)		0.473		liter		2.113		pt
US quart (US qt, liquid)		0.946		liter		1.057		US qt, liquid
US quart (US qt, dry)		1.101		liter		0.9080		US qt, dry
US gallon (US gal)		3.785		liter		0.2642		US gal
Imperial gallon (Imp. gal)		4.546		liter		0.2200		Imp. gal
bushel (bu)		35.24		liter		0.02838		bu
acre-foot (ac-ft)		1233		cubic meter (m ³)		0.000810		ac-ft
acre-inch (ac-in)		102.8		cubic meter (m ³)		0.009729		ac-in
pint/acre (pt/ac)		1.169		liter hectare (liter/ha)		0.8553		pt/ac
quart/acre (qt/ac)		2.339		liter hectare (liter/ha)		0.4276		qt/ac
US gallon/acre (US gal/ac)		9.355		liter hectare (liter/ha)		0.1069		US gal/ac
cubic foot/second (cu ft/s)		0.02832		cubic meter second (m ³ /s)		35.31		cu ft/s
cubic foot/second (cu ft/s)		28.32		liter second (liter/s)		0.03531		cu ft/s
cubic foot/minute (cfm)		0.000471		cubic meter second (m ³ /s)	2119			cfm

continued on next page

Appendix A. continued

Non-SI metric unit	x	factor	= SI metric unit	x	factor	= non-SI metric unit
Velocity						
foot/second (ft/s)		0.3048	meter/second (m/s)		3.281	ft/s
Force						
ounce (oz)		0.278	newton (N)		3.597	oz
pound (lb)		4.448	newton (N)		0.2248	lb
ton (2205 lb)	10985		newton (N)		0.000091	ton (2205 lb)
kilogram force (kgf)		9.80665	newton (N)		0.10197	kgf
Pressure						
pound/square inch (psi)		6895	pascal (Pa)		0.000145	psi
pound/square foot (psf)		47.88	pascal (Pa)		0.02089	psf
in of water		248.8	pascal (Pa)		0.004109	in of water
in of mercury		3377	pascal (Pa)		0.000296	in of mercury
in of mercury		0.03377	bar	29.61		in of mercury
atmosphere	101300		pascal (Pa)		0.00009869	atmosphere
atmosphere		1.013	bar		0.9869	atmosphere
Energy						
British thermal unit (BTU)		1.055	kilojoule (kJ)		0.9479	BTU
foot-pound (ft-lb)		1.356	joule (J)		0.7376	ft-lb
horsepower-hour (hp-h)		2.685	megajoule (MJ)		0.3725	hp-h
kilowatt-hour (kWh)		3.600	megajoule (MJ)		0.2778	kWh
calorie (c)		4.187	joule (J)		0.2388	calorie
therm	105.5		megajoule (MJ)		0.009479	therm
langley		4.186	joule/square centimeter (J/cm ²)		0.2389	langley
British thermal unit/hour-foot-degree Fahrenheit (BTU/h-ft-°F)		1.729	watt/meter-kelvin (W/m-K)		0.5783	BTU/h-ft-°F
British thermal unit-inch/hour-square foot-degree Fahrenheit (BTU-in/h-sq ft-°F)		0.1442	watt/meter-kelvin (W/m-K)		6.933	BTU in/h-sq ft-°F
British thermal unit/hour-square foot (BTU/h-sq ft)		3.169	watt/square meter (W/m ²)		0.3155	BTU/h-sq ft
langley/minute (langley/min)	698.0		watt/square meter (W/m ²)		0.001433	langley/min
langley		41.86	kilojoule/square meter (kJ/m ²)		0.02389	langley
British thermal unit/square foot (BTU/sq ft)		11.4	kilojoule/square meter (kJ/m ²)		0.08772	BTU/sq ft
British thermal unit/US gallon (BTU/US gal)		0.2785	kilojoule/liter (kJ/liter)		3.591	BTU/US gal
British thermal unit/pound (BTU/lb)		2.326	kilojoule/kilogram (kJ/kg)		0.4299	BTU/lb
Power						
British thermal unit/minute (BTU/min)		0.01759	kilowatt (kW)		56.86	BTU/min
horsepower (hp)		0.7457	kilowatt (kW)		1.341	hp
foot-pound/minute (ft-lb/min)		0.02260	watt (W)		44.25	ft-lb/min
ton (refrig)		3.517	kilowatt (kW)		0.2843	ton (refrig)

REFERENCE CITED

Allbright L D (1978) Metrification. Agric. Eng. Ext. Bull. 423. Cornell University, Ithaca, New York. 16 p. (adapted)

Appendix B. Rates of work, draft, and power

Rates of work ¹	Person-h/ha
Manual tillage	
Slash and burn	240-360
Tillage with hoe	100-300
Hoeing, flooded soil	100-200
Spade, 25 cm depth	500
Animal tillage	
2 oxen with ridging plow	10
2 oxen with ard	30
4 horses with 2-bottom 14" moldboard	5.0
6 horses with 2-bottom 14" moldboard	4.8
12 horses with 3-bottom 16" moldboard	2.7
6 horses with 8-ft tandem disk harrow	1.8
4 horses with 12-ft spike-tooth harrow	0.8
8 horses with 12-ft spring-tooth harrow	1.2
Water buffalo plowing flooded soil	30-60
Water buffalo comb harrowing	40-60
5 water buffalo trampling (puddling) wet soil	32-40
2 bullocks with plank leveller	15
Tractor tillage	
4.5-hp pedestrian tiller	4.2
4.5-hp tractor and 4-bottom disk plow	1.3
80-hp tracklayer and 7-bottom disk plow	0.7
5-hp power tiller plowing wet soil	20-40
10-hp double-axle pedestrian tractor tilling wet soil	6-8
10-hp hydrotiller	4.4
12.5-hp compact tractor plowing wheat stubble	11-14
40-hp tractor rotovating wet soil	2.1
5-hp single-axle pedestrian tractor with puddling wheels and comb harrow	20
Clearing virgin forest with tracklayer	69.2
Clearing secondary forest with tracklayer	44.5
Clearing bush with tracklayer	12.3
Manual planting	
Broadcasting	3.3
Using dibble stick	160
Seeding in premarked rows and covering by foot	80
Push- or pull-type planter in dry soil	20
IRRI row seeder with pregerminated rice seed sown in wet soil	5-7
Animal planting	
Bullock-drawn seed drill	5.3
2 bullocks and ard, broadcasting and covering seed	21
4 horses and 8-ft disk drill	1.4
6 horses and 12-ft disk drill	0.9
2 horses and 2-row maize planter	1.8
2 horses and 1-row potato planter	4.3

continued on next page

Appendix B. continued

Rates of work¹	Person-h/ha
Tractor planting	
Airplane broadcasting of rice	0.3-0.6
5-hp pedestrian seeder (rice)	8
60-hp tractor and 4-row maize planter	0.7
Manual weed and pest control	
Hand weeding transplanted rice	120-320
Hand weeding rice in broadcast field	1150
Hand weeding rice in dibbled field	380
Hand weeding rice in drilled field	321
Rotary push-type weeder in rice	30-150
Hand-carried IRRI power weeder	17
Knapsack sprayer	13-50
Dusting	7-16
Animal weed and pest control	
2 horses and 2-row (maize) shovel cultivator	2.4
Tractor weed and pest control	
35-hp tractor with cultivator	2.4-3
Airplane applying herbicide	0.2
Knapsack power duster (in rice)	2
Tractor-mounted sprayer (in rice)	0.5
Manual harvesting, threshing, and processing	
Harvesting rice with sickle or knife	60-80
Reaping with a scythe	34
Bundling rice into sheaves	24
Hauling sheaves to thresher	39
Threshing rice with hand sticks	182
Threshing rice with flail	20-30
Threshing rice on a bamboo ladder	30-60
Winnowing grain by tossing in wind	40 kg/h
Hand-driven winnower	200-1200 kg/h
Harvesting, threshing, and processing with animals	
2 horses and 6-ft reaper	1.7
4 horses and 8-ft binder	1.4
2 horses and 1 -row maize binder	2.8
6 horses and 1 -row maize picker	3.2
16 horses and 14-ft combine	1.0
2 horses and 6-ft mower mowing hay	2.0-2.4
2 oxen threshing by treading	60-89
Engine-powered harvesting, threshing, and processing	
5-hp pedestrian windrower	5.4-1 0
Threshing rice by treading with 5 water buffalo	120 kg/h
Threshing rice by treading with tractor	600-2000 kg/h
5-hp IRRI axial-flow thresher, 4 men feeding	350-700 kg/h
Small (1/2-m) combine	0.18 t grain/h

continued on opposite page

Appendix B. continued**Equations for draft and power requirements²**

(S = km/h or mph, d = depth in cm or in, M = mass in kg or lb,
F = throughput rate in kg/sec or lb/sec)

Moldboard plow draft per unit of cross-section of furrow slice:

Sand : Draft (N/cm²) = 2 + 0.013 S²
Draft (lb/in²) = 3 + 0.05 S²

Loam : Draft (N/cm²) = 3 + 0.020 S²
Draft (lb/in²) = 4.5 + 0.08 S²

Silty clay : Draft (N/cm²) = 7 + 0.049 S²
Draft (lb/in²) = 10.24 + 0.185 S²

Disk plow draft per unit of cross-section of furrow slice:

Loam : Draft (N/cm²) = 2.4 + 0.045 S²
Draft (lb/in²) = 3.4 + 0.17 S²

Clay : Draft (N/cm²) = 5.2 + 0.039 S²
Draft (lb/in²) = 7.6 + 0.15 S²

Lister at 6.75 km/h and 36-cm bottom:

Silty clay loam : Draft (N/cm²) = 21.5 d²
Draft (lb/in²) = 31.2 d²

Disc harrow : Draft (N/cm²) = 11.7 M
Draft (lb/in²) = 1.2 M

Field cultivator operating at 8.3-cm depth, draft per tool:

Clay loam : Draft (N/cm²) = 480 + 48.1 S
Draft (lb/in²) = 108 + 16 S

Subsoiler draft per shank:

Medium or clay loam : Draft (N/shank) = 175 d-280 d
Draft (lb/shank) = 100 d-160 d

Landplane,

draft per unit width : Draft (N/m) = 4400-11600
Draft (lb/ft) = 300-800

Spike-tooth harrow : Draft (N/m) = 440-730
Draft (lb/ft) = 30-50

Spring-tooth harrow : Draft (N/m) = 1460-2190
Draft (lb/ft) = 100-150

Rod weeder : Draft (N/m) = 880-1830
Draft (lb/ft) = 60-125

Roller or packer : Draft (N/m) = 440-880
Draft (lb/ft) = 30-60

Row planter in loam soil and good seedbed:

Seeding only : Draft (N/row) = 450-800
Draft (lb/row) = 100-180

Seed, fertilizer,
herbicide : Draft (N/row) = 1100-2000
Draft (lb/row) = 250-450

continued on next page

Appendix B. continued

Grain drill	:	Draft (N/furrow opener) = 130-450 Draft (lb/furrow opener) = 30-100
Row cultivator	:	Draft (N/m width) = 115d-230d Draft (lb/ft width) = 20d-40d
Rotary hoe	:	Draft (N/m width) = 440 + 21.7 S Draft (lb/ft width) = 30 + 2.4 S
Anhydrous ammonia applicator		Draft = 1800 N/knife Draft = 400 lb/knife
Potato digger		Draft of 2.2-3.5 kN/row + rotary power of 0.75-1.5 kW/row Draft of 500-800 lb/row + rotary power of 1-2 hp/row
Sugar beet harvester		Draft of 2 to 4 kN/row + rotary power of 1.5-3.0 kW/row Draft of 450-900 lb/row + rotary power of 2-4 hp/row
Rotary power at implement engine or tractor PTO for field machines (does not include power required to overcome rolling resistance):		
Cutter bar mower	:	1.2 kW/m of cut 0.5 hp/ft of cut
Cutter bar mower conditioner	:	3.5-4.90 kW/m of cut 1.5-2 hp/ft of cut
Flail mower-conditioner	:	(8.2 + 2.13 F) kW (11.0 + 1.3 F) hp
Side delivery rake (2.4 m or 8 ft wide)	:	(-0.186 + 0.052 S) kW (-0.25 + 0.25 S) hp
Baler, rectangular	:	(2.95 F) kW (1.8 F) hp
Baler, rectangular, tough crop, high density	:	(4.4 F) kW (2.7 F) hp
Forage harvester, precision-cut		
Maize	:	(1.5 + 3.3 F) kW (2 + 2 F) hp
Green alfalfa	:	(2.0 + 4.4 F) kW (2.7 + 2.7 F) hp
Haylage or hay	:	(3.0 + 6.6 F) kW (4 + 4 F) hp
Self-propelled combine (20% MC straw, chaff, and husks)		
Small grain and beans	:	(7.5 + 7.5 F) kW (10 + 4.6 F) hp
Maize	:	(22.5 + 22.5 F) kW (30 + 13.8 F) hp
Cotton picker	:	7.5-11.0 kW/row 10-15 hp/row

Appendix C. Bullock training¹

Nose ringing

Bullocks must have nose rings fixed for control and guidance. The rings must be made of durable metal. No ropes or corrosive rings should be used.

To insert the ring, the animal's head should be put down with the horns resting on the ground and the nose in the air. The nose should be pulled out slightly and the ring pierced through the soft part. The ring must be examined afterwards and sharp pieces of metal removed.

Dehorning

To prevent bullocks from injuring each other, the tips of the horns must be removed. Care has to be taken that not too much is removed to avoid bleeding. Some horn is advantageous because it prevents the animal from pulling its head out of the yoke.

If bleeding occurs, use a clean cloth or cotton wool to stop it. Cover the bandage with Gentian Violet or Stock balm to prevent infection, and wash off the blood.

Training

Training is divided into several sections. The time spent in each section of the training varies considerably depending on the temperament of the animal and its ability to learn. Training should be done during the cooler parts of the day.

In the morning	7-11 am
In the evening	4-6 pm

As few people as possible should be present during training to prevent the bullock from becoming nervous. Bullocks also become nervous when the training is done too quickly, or when the trainer shouts or beats them. The general rule is: Never Beat Bullocks.

Preparation for training (7 d)

At first, the animal must be calmed. Through frequent petting and talking during feeding and watering, it grows accustomed to its trainer. The bullock's movements should be restricted by either tying it to a post or stabling it. Names can be given to bullocks, as this will be helpful later during verbal training.

Yoking (3 d)

Two types of shoulder yokes, 5- and 7-ft wide, are used with bullocks. The shorter yoke is easier to use in the yoking. The trainer may need assistance in the yoking because of the temper of the animals. The stronger animal should always be on the right side, especially when plowing, for the right-hand bullock must walk on plowed ground.

The rope between the nose rings should be shortened for untrained bullocks so that their heads are slightly turned toward one another. Once the animals are trained, a longer rope can be used.

On the second day, the bullocks should be yoked and taught to move as a team.

327 DIBBLE STICKS, DONKEYS, AND DIESELS

On the third day, the teaching of verbal signals for starting and stopping should begin. The verbal signals must sound different so that the bullocks will not be confused.

Starting bullocks	"hass"
Stopping bullocks	"op!"

A trail should be used to teach them to walk in a straight line.

Pulling a sled (3-6 d)

The bullocks must get used to pulling weight. A flat wooden sled (size 1 - 1/2 x 3 ft), which can be used later for transporting the implements to the field, is advisable.

The teaching of verbal and physical signals for starting, stopping, turning, and backing should continue from the first day. The next day apply some extra weight to the platform or use a log to get the bullocks used to pulling heavy weight for a period of time. Teaching of signals should continue.

On the third day, begin practicing walking in straight lines on a field with continued teaching of signals.

Another 2-3 d may be needed for field practice. A furrow should be made across the field to teach the bullocks to follow it. To learn to walk in the furrow, the animals must be alternated.

Field equipment (7d)

About 1 wk should be allocated for field training with equipment such as plows, ridgers, or carts. Considerable practice is needed to teach the animals to pull in a straight line and to enable the trainer to learn how to control them and the plow or ridger at the same time. Patterns should be avoided in the training, because the bullocks may begin to move by habit and not by command.

REFERENCE CITED

1. German Agency for Technical Cooperation (1977) Agricultural extension handbook. Ghanaian-German Agricultural Development Project, Northern and Upper Regions. Eschborn, Federal Republic of Germany.

POWER TAKE-OFF PERFORMANCE

Power Hp (kW)	Crank shaft speed rpm	Fuel Consumption			Temperature ° (°C)			Barometer inch Hg (kPa)
		gal/hr (l/h)	lb/hp.hr (kg/kW.h)	Hp.hr/gal (kW.h/l)	Cooling medium	Air wet bulb	Air dry bulb	

MAXIMUM POWER AND FUEL CONSUMPTION

Rated Engine Speed — Two hours (PTO Speed—998 rpm)								
115.67 (86.26)	2100	6.657 (25.197)	0.402 (0.244)	17.38 (3.423)	189 (87.0)	58 (14.5)	75 (23.9)	28.96 (97.78)

Maximum PTO horsepower is a convenient means to compare the relative size of tractors, but it is not a true measure of how much power will be available in the field.

VARYING POWER AND FUEL CONSUMPTION — Two Hours

101.61 (75.77)	2170	6.100 (23.089)	0.419 (0.255)	16.66 (3.281)	188 (86.7)	58 (14.4)	74 (23.3)
0.00 (0.00)	2260	1.870 (7.078)	186 (85.6)	57 (13.9)	74 (23.3)
51.73 (38.58)	2211	3.981 (15.067)	0.537 (0.327)	13.00 (2.560)	188 (86.4)	59 (14.7)	75 (23.9)
116.30 (86.73)	2100	6.667 (25.237)	0.400 (0.243)	17.44 (3.436)	187 (86.1)	58 (14.4)	75 (23.6)
26.11 (19.47)	2232	2.936 (11.113)	0.785 (0.477)	8.89 (1.752)	186 (85.6)	58 (14.4)	75 (23.9)
77.10 (57.49)	2197	5.055 (19.135)	0.458 (0.278)	15.25 (3.004)	187 (85.8)	58 (14.4)	74 (23.3)
Av 62.14 (46.34)	2195	4.435 (16.787)	0.498 (0.303)	14.01 (2.760)	187 (86.0)	58 (14.4)	74 (23.6)	28.90 (97.60)

Average fuel efficiency in horse-power-hours per gallon. The more efficient the tractor is, the larger this value will be and the greater the fuel economy.

DRAWBAR PERFORMANCE

Power Hp (kW)	Drawbar pull lbs (kN)	Speed mph (km/h)	Crank- shaft speed rpm	Slip %	Fuel Consumption			Temp. °F (°C)			Barom. inch Hg (kPa)
					gal/hr (l/h)	lb/hp.hr (kg/kW.h)	Hp.hr/gal (kW.h/l)	Cool- ing med	Air wet bulb	Air dry bulb	
Maximum Available Power — Two Hours 8th (3-2) Gear											
100.56 (74.99)	5915 (26.31)	6.38 (10.26)	2101	3.90	6.613 (25.032)	0.459 (0.279)	15.21 (2.996)	187 (85.8)	52 (10.8)	61 (15.8)	28.39 (95.85)
75% of Pull at Maximum Power — Ten Hours 8th (3-2) Gear											
79.68 (59.41)	4463 (19.85)	6.69 (10.77)	2184	2.84	5.723 (21.663)	0.501 (0.305)	13.92 (2.743)	189 (87.2)	33 (0.4)	41 (4.7)	29.18 (98.53)
50% of Pull at Maximum Power — Two Hours 8th (3-2) Gear											
54.18 (40.40)	2975 (13.23)	6.83 (10.99)	2208	1.99	4.535 (17.167)	0.584 (0.355)	11.95 (2.353)	189 (87.2)	56 (13.1)	57 (13.6)	28.71 (96.95)
50% of Pull at Reduced Engine Speed — Two Hours 10th (4-1) Gear											
54.23 (40.44)	2975 (13.23)	6.84 (11.00)	1449	1.91	3.740 (14.157)	0.481 (0.293)	14.50 (2.857)	186 (85.6)	59 (14.7)	59 (15.0)	28.68 (96.85)

Fuel efficiency at 50% of pull. Note that fuel efficiency is higher at reduced speed than at maximum throttle, which shows that throttling back and shifting to a higher gear saves fuel.

continued on opposite page

Appendix D. continued

MAXIMUM POWER IN SELECTED GEARS									
78.27 (58.36)	12915 (57.45)	2.27 (3.66)	2161	14.86	2nd (1-2) Gear	188 (86.7)	44 (6.7)	47 (8.3)	28.51 (96.27)
94.28 (70.30)	12476 (55.49)	2.83 (4.36)	2099	12.54	3rd (1-3) Gear	188 (86.4)	45 (7.2)	48 (8.9)	28.49 (96.21)
95.94 (71.54)	12348 (54.93)	2.91 (4.69)	2100	12.08	4th (2-1) Gear	189 (87.2)	46 (7.8)	49 (9.4)	28.47 (96.14)
100.65 (75.05)	9166 (40.77)	4.12 (6.63)	2100	6.77	5th (2-2) Gear	188 (86.4)	47 (8.3)	50 (10.0)	28.45 (96.07)
101.28 (75.52)	8103 (36.04)	4.69 (7.54)	2101	5.80	6th (3-1) Gear	190 (87.8)	47 (8.3)	51 (10.6)	28.44 (96.04)
100.10 (74.64)	7145 (31.78)	5.25 (8.45)	2100	4.90	7th (2-3) Gear	189 (87.2)	48 (8.9)	52 (11.1)	28.43 (96.00)
101.40 (75.62)	5968 (26.54)	6.37 (10.25)	2100	3.74	8th (3-2) Gear	187 (86.1)	52 (11.1)	62 (16.7)	28.37 (95.80)
98.65 (73.57)	4603 (20.48)	8.04 (12.93)	2100	2.95	9th (3-3) Gear	187 (85.8)	49 (9.4)	53 (11.7)	28.42 (95.97)

LUGGING ABILITY IN 8th (3-2) GEAR						
Crankshaft Speed rpm	2100	1890	1680	1472	1236	1042
Pull—lbs (kN)	5968 (26.54)	6620 (29.45)	7141 (31.76)	7743 (34.44)	8311 (36.97)	7537 (33.53)
Increase in Pull %	0	11	20	30	39	26
Power—Hp (kW)	101.40 (75.62)	100.59 (75.01)	96.16 (71.70)	90.83 (67.74)	81.44 (60.73)	62.64 (46.71)
Speed—Mph (kmh)	6.37 (10.25)	5.70 (9.17)	5.05 (8.13)	4.40 (7.08)	3.67 (5.91)	3.12 (5.02)
Slip %	3.74	4.59	4.90	5.35	5.80	5.20

Percent Increase in pull at reduced crankshaft speeds. A tractor whose pulling power rises substantially during the first 20% reduction in speed has good lugging ability. This tractor's pull increases 9% when speed drops 30%.

TRACTOR SOUND LEVEL WITH CAB	dB(A)
Maximum Available Power—Two Hours	77.0
75% of Pull at Maximum Power—Ten Hours	77.5
50% of Pull at Maximum Power—Two Hours	77.0
50% of Pull at Reduced Engine Speed—Two Hours	74.5
Bystander in 12th (4-3) gear	87.5

TIRES, BALLAST AND WEIGHT		With Ballast	Without Ballast
Rear Tires	-No., Size, ply & psi (kPa);	Inner Two 18.4-38: 8: 16(110) Outer Two 18.4-38: 6: 16(110)	Inner Two 18.4-38: 8: 16(110) Outer Two 18.4-38: 6: 16(110)
Ballast	-Liquid (each) -Cast Iron (each)	None 161 lb 73 (kg)	None None
Front Tires	-No., Size ply & psi (kPa)	Two 11.00-16SL:6: 32 (220)	Two 11.00-16SL: 6: 32 (220)
Ballast	-Liquid (each) -Cast Iron (each)	None 58 lb (26kg)	None None
Height of Drawbar		19.5 in (495mm)	19.5 in (495 mm)
Static Weight with Operator	-Rear -Front -Total	1130 lb (5139 kg) 3610 lb (1637 km) 14940 lb (6776 kg)	10685 lb (4847 kg) 3495 lb (1585 kg) 14180 lb (6432 kg)

REFERENCE CITED

Koelsch R K (1978) Choosing a tractor using the Nebraska Tractor Tests. Northeast Regional Agricultural Engineering Service, Cornell University, Ithaca, New York. NRAES FS-16.