

B

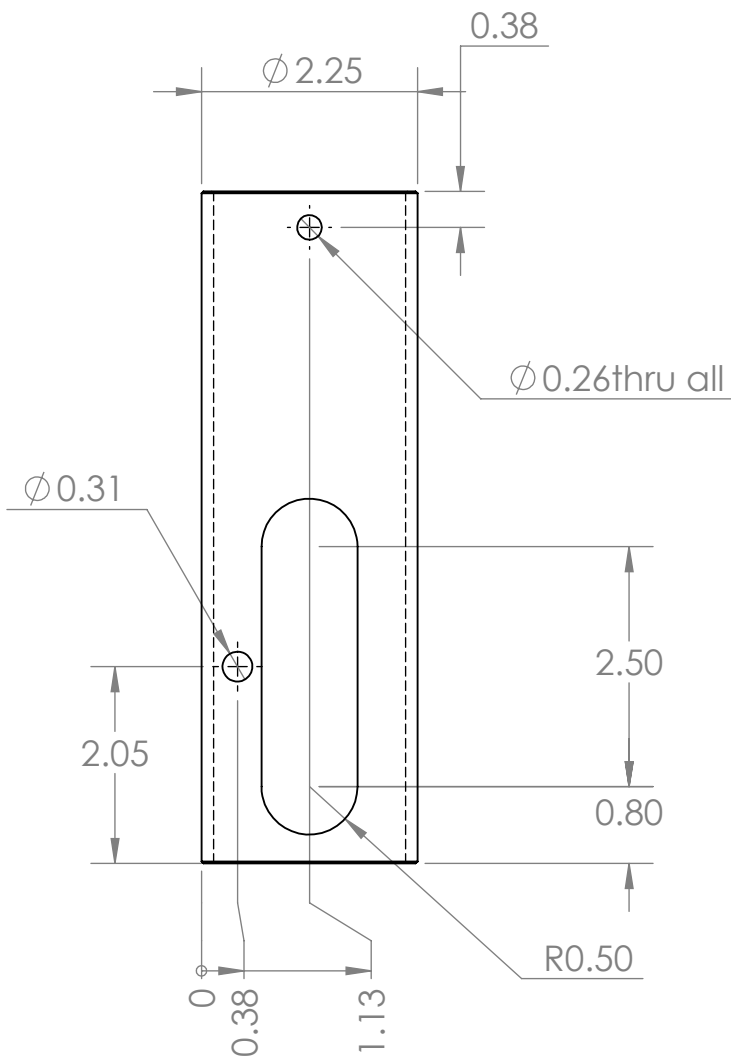

B

UNLESS OTHERWISE SPECIFIED:		NAME	DATE	BAE LABORATORY	
DIMENSIONS ARE IN INCHES	DRAWN	WRK		TITLE:	
TOLERANCES:	CHECKED			7"X2.5"ODX2"ID	
FRACTIONAL \pm	ENG APPR.			6061-T6	
ANGULAR: MACH \pm BEND $\pm .01$	MFG APPR.			ALUMINUM	
TWO PLACE DECIMAL $\pm .005$	Q.A.			TUBING	
THREE PLACE DECIMAL $\pm .005$	COMMENTS:			SIZE	DWG. NO.
INTERPRET GEOMETRIC TOLERANCING PER:				ATICK	PLANTER
MATERIAL					REV
FINISH					
DO NOT SCALE DRAWING				SCALE: 1:8	WEIGHT:
					SHEET 13 OF 13

A

2

1

A