

ITEM NO.	PART NUMBER	DESCRIPTION	QTY.
1	HP14-OSU-P001 EXTERNAL HOUSING1.125	7"X2.5"ODX2"ID 6061-T6 ALUMINUM TUBING	1
2	PIN	1.25"LONG X .3125 OD 6061-T6 ROD	1
3	HP14-OSU-P002 METER HOUSING	5.75"LONG X 2 OD TYPE 507 BLACK DELRIN	1
4	HPR-OSU-P041s	2.5"X 1" TYPE 507 DELRIN	1
5	HP14-OSU-P003	2.25" X 1 X .25 507 DELRIN	1
6	TIPASSY		1

NOTE:  
ALL DIMENSIONS  
FOR ALL DRAWINGS  
ARE IN INCHES.

UNLESS OTHERWISE SPECIFIED:		NAME	DATE	OSU HAND PLANTER	
DIMENSIONS ARE IN INCHES		DRAWN	RT	TITLE:	
TOLERANCES:		CHECKED		<b>HAND PLANTER</b>	
FRACTIONAL ±		ENG APPR.		SIZE	DWG. NO.
ANGULAR: MACH ± BEND ±		MFG APPR.		<b>A</b>	
TWO PLACE DECIMAL ±.01		Q.A.		SCALE: 1:2	SHEET 1 OF 11
THREE PLACE DECIMAL ±.005		COMMENTS:			
INTERPRET GEOMETRIC TOLERANCING PER:					
MATERIAL					
FINISH					
DO NOT SCALE DRAWING					

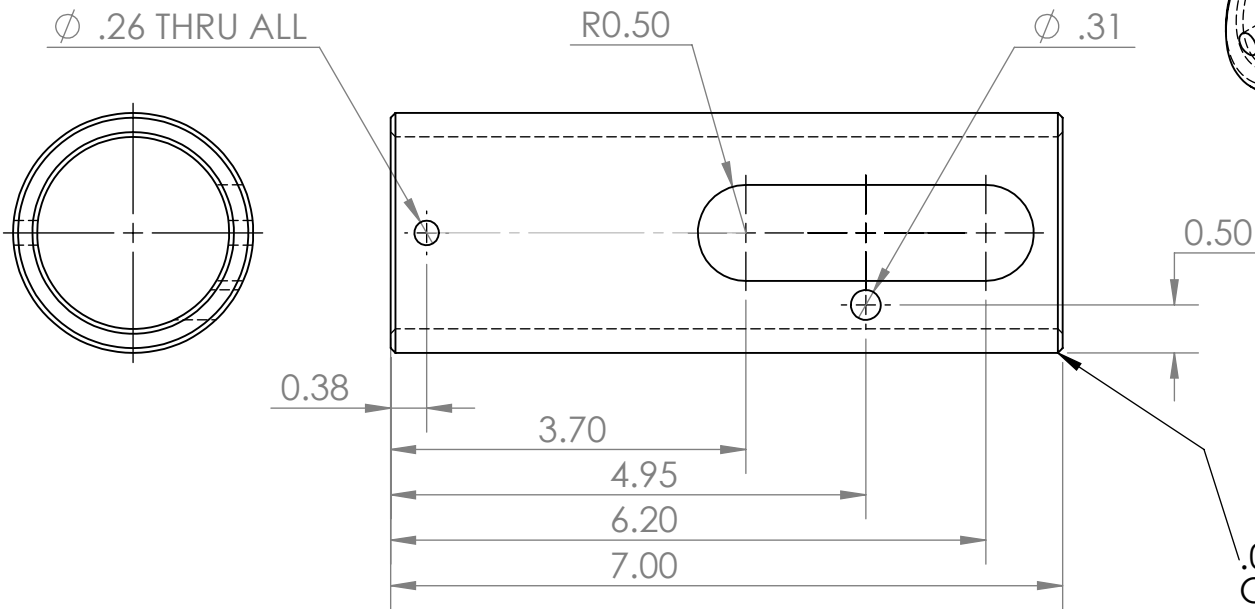

.05 X 45 CHAMFER BOTH ENDS ON BOTH ID AND OD.

UNLESS OTHERWISE SPECIFIED:		NAME	DATE	OSU HAND PLANTER	
DIMENSIONS ARE IN INCHES		DRAWN	RT	TITLE:	
TOLERANCES:		CHECKED		<b>EXTERNAL HOUSING</b>	
FRACTIONAL $\pm$		ENG APPR.		SIZE	DWG. NO.
ANGULAR: MACH $\pm 1$ BEND $\pm$		MFG APPR.		<b>A</b>	
TWO PLACE DECIMAL $\pm .01$		Q.A.		SCALE: 1:2	WEIGHT:
THREE PLACE DECIMAL $\pm .005$		COMMENTS:			SHEET 2 OF 11
INTERPRET GEOMETRIC TOLERANCING PER:					
MATERIAL					
6061-T6 ALUM					
FINISH					
DO NOT SCALE DRAWING					



0.13 SLOT 1.75 DEEP

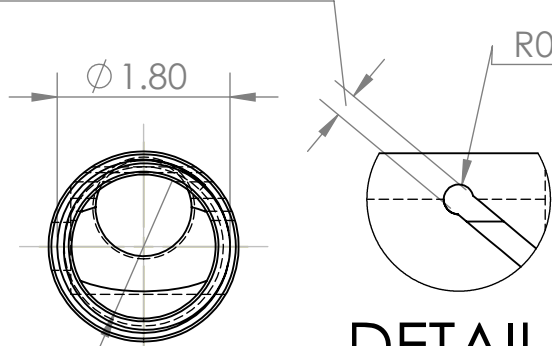

**DETAIL C**  
SCALE 1 : 1

DRILL  $\phi$  1.50  $\nabla$  3.60

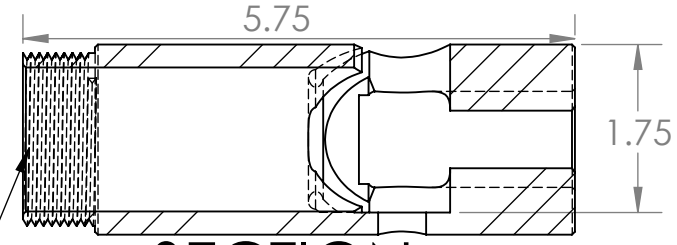
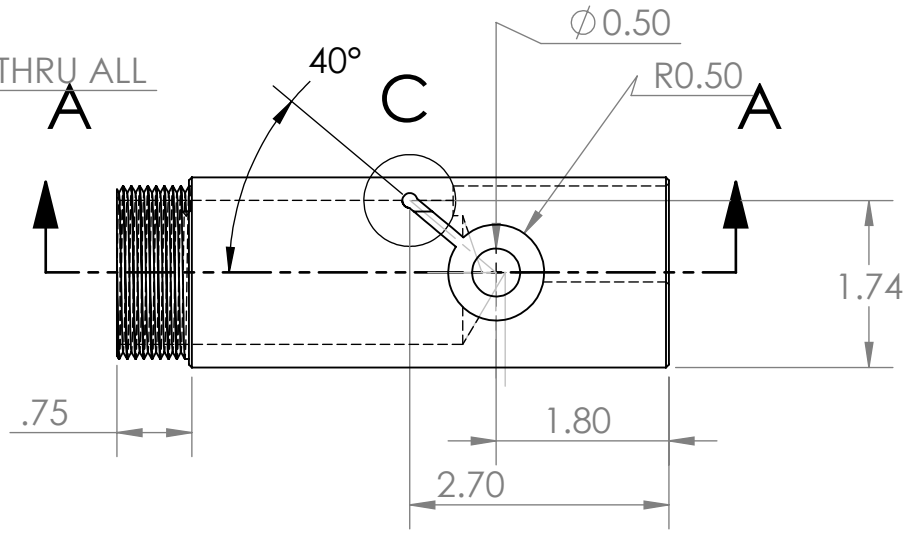
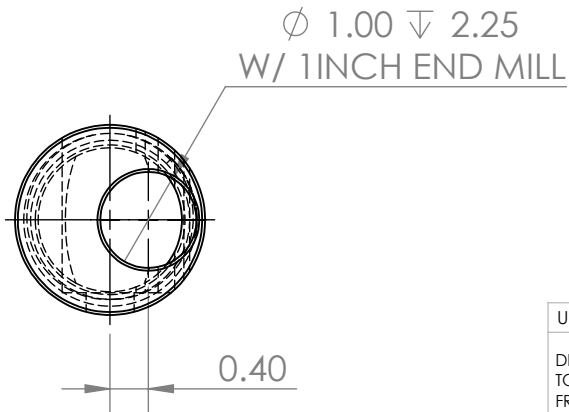

**SECTION A-A**

NOTE:  
11.5 TPI WITH 1.8 MAJOR DIAM.  
MUST BE ABLE TO THREAD 1.5 PVC  
THREADED COUPLER SO IT CONTACTS  
STEP. RELIEF CUT IS ALLOWED

NOTE:  
ALL CHAMFERS  
ARE  
45DEGREE X .03"

UNLESS OTHERWISE SPECIFIED:		NAME	DATE	OSU HAND PLANTER			
DIMENSIONS ARE IN INCHES		DRAWN	RT			TITLE:	
TOLERANCES:		CHECKED		<b>METER HOUSING</b>			
FRACTIONAL $\pm$		ENG APPR.				SIZE	DWG. NO.
ANGULAR: MACH $\pm$ 1 BEND $\pm$		MFG APPR.				<b>A</b>	
TWO PLACE DECIMAL $\pm$ .01		Q.A.		SCALE: 1:2	WEIGHT:		
THREE PLACE DECIMAL $\pm$ .005		COMMENTS:			SHEET 3 OF 11		
INTERPRET GEOMETRIC TOLERANCING PER:							
MATERIAL							
507 BLACK DELRIN							
FINISH							
DO NOT SCALE DRAWING							



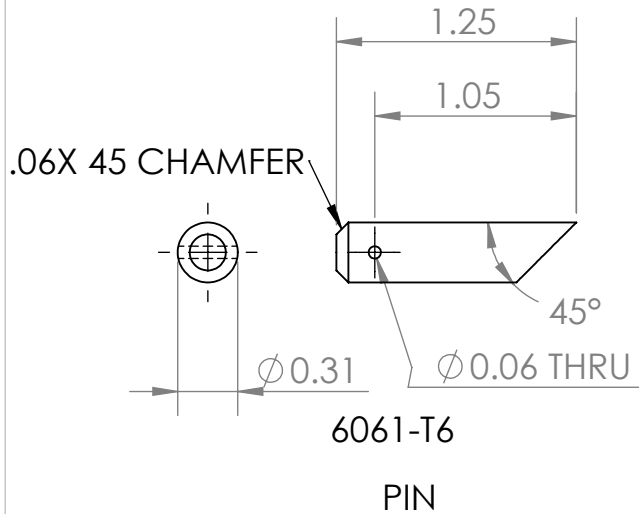

RELIEF CUT ALLOWED  
IF NEEDED.

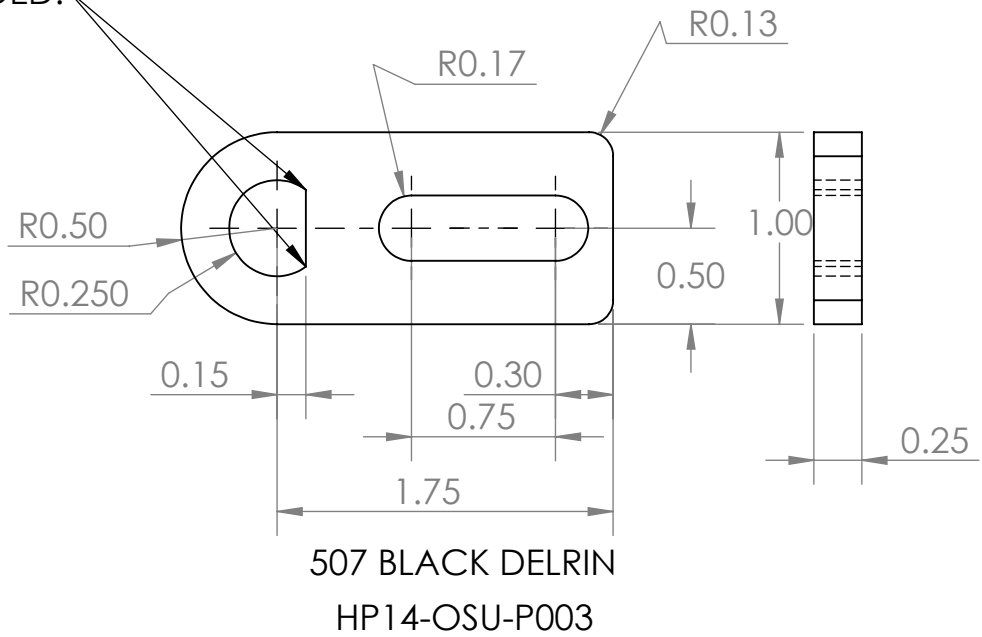

UNLESS OTHERWISE SPECIFIED:		NAME	DATE	OSU HAND PLANTER		
DIMENSIONS ARE IN INCHES		DRAWN	RT			TITLE:  <b>PIN AND LEVER</b>
TOLERANCES:		CHECKED				
FRACTIONAL ±		ENG APPR.				
ANGULAR: MACH ± 1 BEND ±		MFG APPR.				
TWO PLACE DECIMAL ±.01		Q.A.		SIZE	DWG. NO.	REV
THREE PLACE DECIMAL ±.005		COMMENTS:		<b>A</b>		
INTERPRET GEOMETRIC TOLERANCING PER:				SCALE: 1:1	WEIGHT:	SHEET 4 OF 11
MATERIAL						
FINISH						
DO NOT SCALE DRAWING						

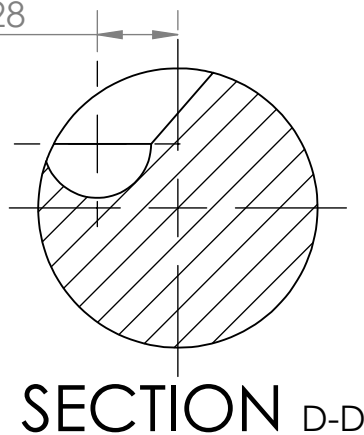
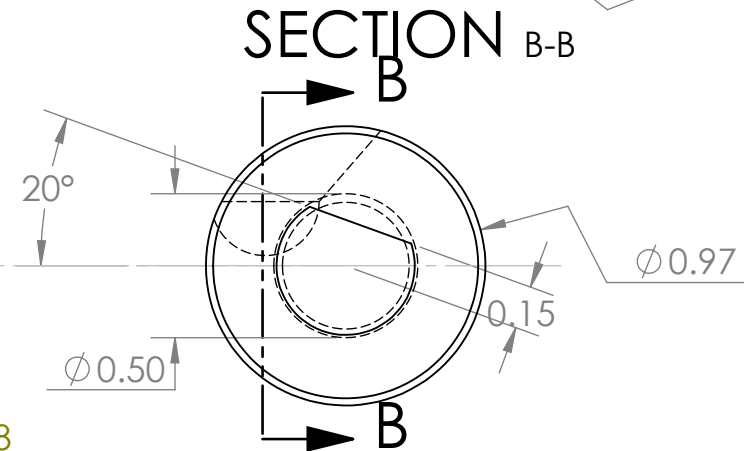
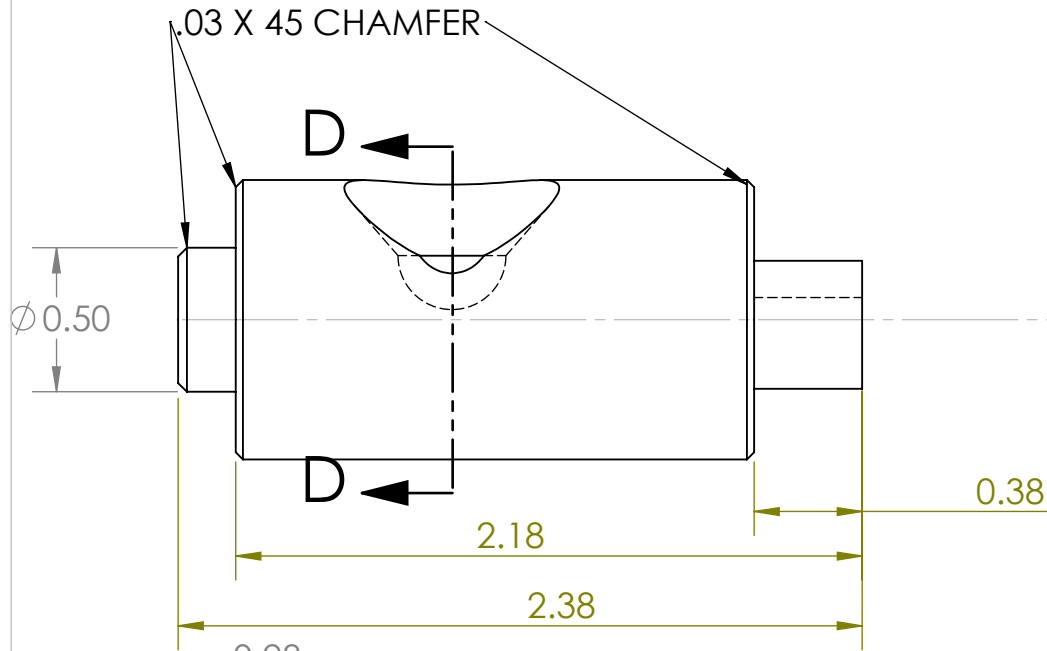
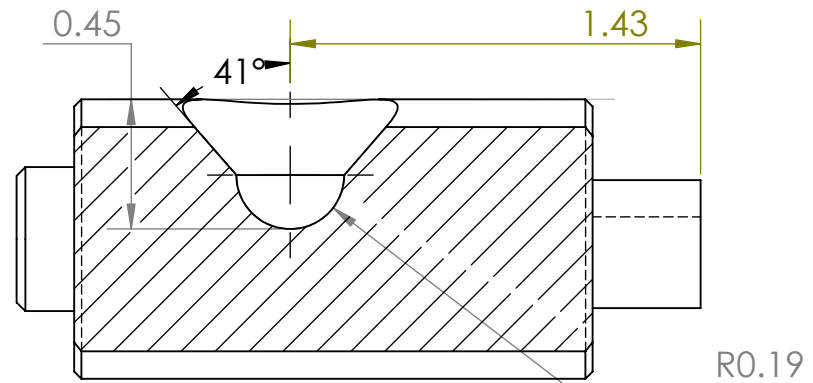
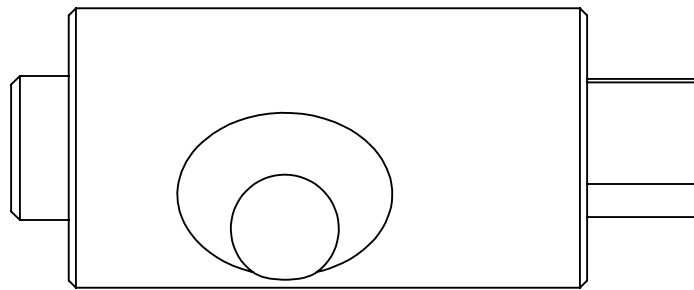

SECTION D-D

UNLESS OTHERWISE SPECIFIED:		NAME	DATE	OSU HAND PLANTER			
DIMENSIONS ARE IN INCHES		DRAWN	RT	TITLE:  HPR-OSU-P041s			
TOLERANCES:		CHECKED					
FRACTIONAL ±		ENG APPR.					
ANGULAR: MACH ± 1 BEND ±		MFG APPR.					
TWO PLACE DECIMAL ±.01		Q.A.		SIZE	DWG. NO.	REV	
THREE PLACE DECIMAL ±.005		COMMENTS:		<b>A</b>			
INTERPRET GEOMETRIC TOLERANCING PER:				SCALE: 1.5:1		WEIGHT:	SHEET 5 OF 11
MATERIAL							
507 DELRIN							
FINISH							
DO NOT SCALE DRAWING							



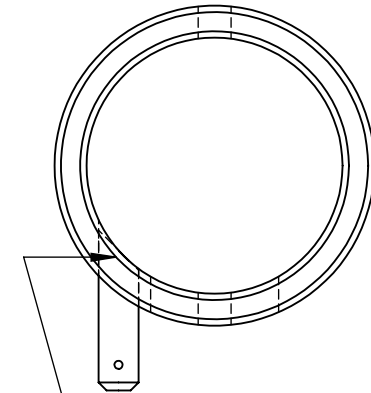
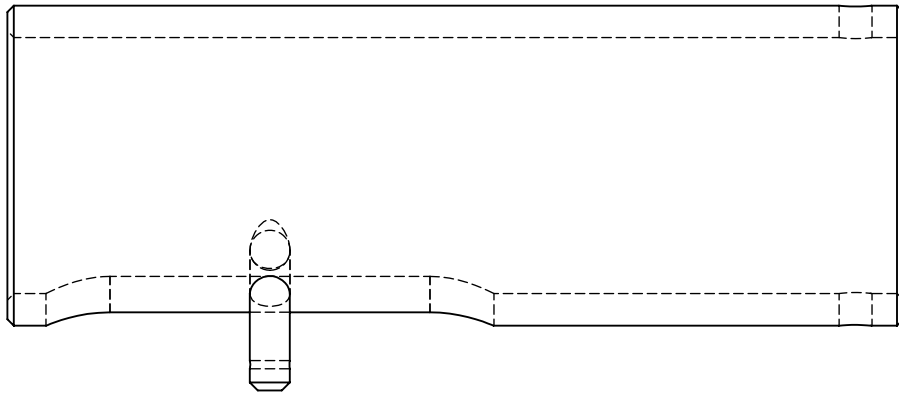

MAKE SURE PIN DOES NOT GO PAST INNER DIAMETER OF TUBE.

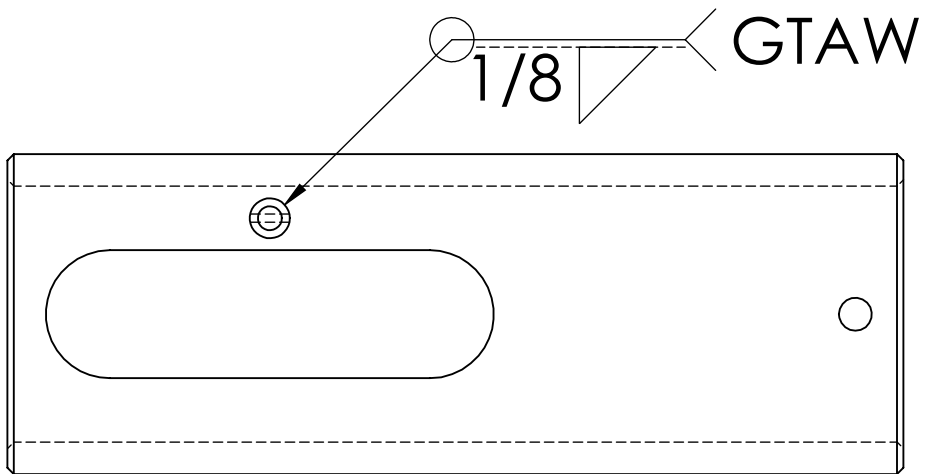

UNLESS OTHERWISE SPECIFIED:		NAME	DATE	OSU HAND PLANTER	
DIMENSIONS ARE IN INCHES		DRAWN	RT	TITLE:  <b>WELD DETAIL</b>	
TOLERANCES:		CHECKED			
FRACTIONAL ±		ENG APPR.			
ANGULAR: MACH ± BEND ±		MFG APPR.			
TWO PLACE DECIMAL ±.01		Q.A.		SIZE	DWG. NO.
THREE PLACE DECIMAL ±.005		COMMENTS:		<b>A</b>	
INTERPRET GEOMETRIC TOLERANCING PER:				SCALE: 1:1.5	WEIGHT:
MATERIAL					SHEET 6 OF 11
FINISH					
DO NOT SCALE DRAWING					



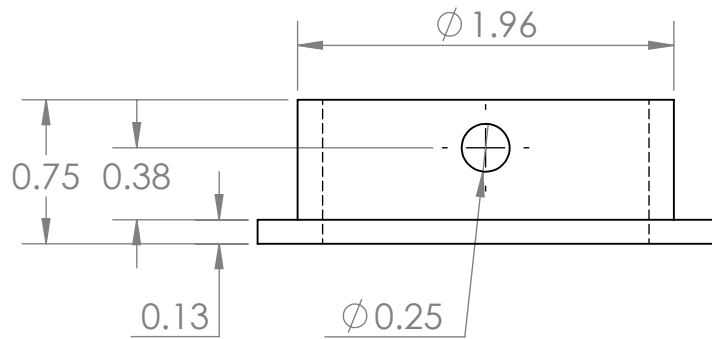
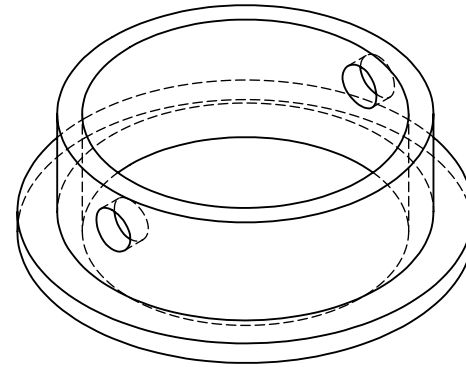
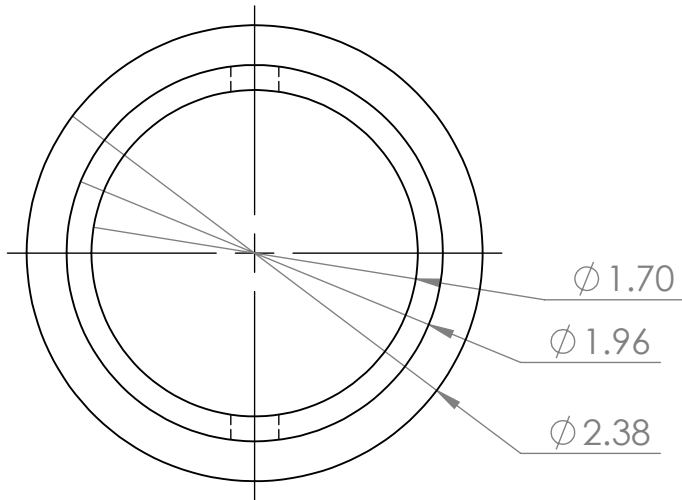

MAKE FROM 2 INCH SCHEDULE 160 PIPE

UNLESS OTHERWISE SPECIFIED:		NAME	DATE	OSU HAND PLANTER	
DIMENSIONS ARE IN INCHES		DRAWN			
TOLERANCES:		CHECKED		TIP COLLAR	
FRACTIONAL $\pm$		ENG APPR.			
ANGULAR: MACH $\pm$ BEND $\pm$		MFG APPR.		SCALE: 1:8 WEIGHT: SHEET 7 OF 11	
TWO PLACE DECIMAL $\pm .01$		Q.A.			
THREE PLACE DECIMAL $\pm .005$		COMMENTS:			
INTERPRET GEOMETRIC TOLERANCING PER:					
MATERIAL					
STEEL					
FINISH					



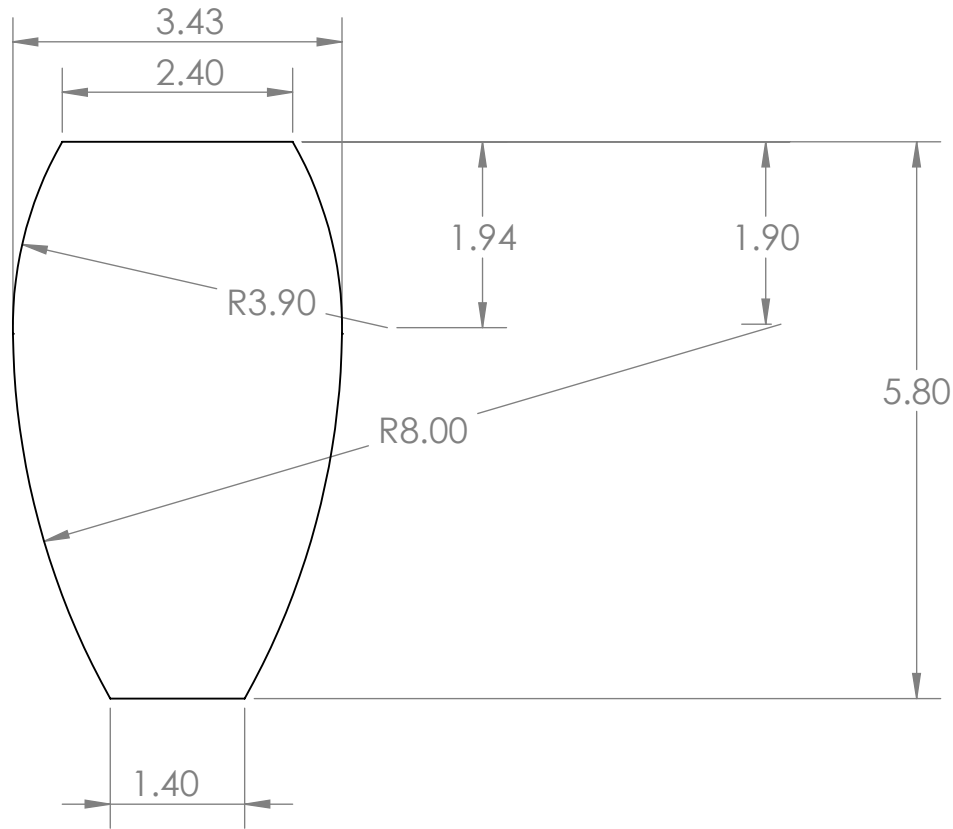

UNLESS OTHERWISE SPECIFIED:  DIMENSIONS ARE IN INCHES TOLERANCES: FRACTIONAL ± ANGULAR: MACH ±    BEND ± TWO PLACE DECIMAL ±.01 THREE PLACE DECIMAL ±.005  INTERPRET GEOMETRIC TOLERANCING PER: MATERIAL <b>STEEL</b> FINISH  DO NOT SCALE DRAWING		NAME	DATE	OSU HAND PLANTER			
	DRAWN						TITLE:  <b>TIP SHOVEL CUTOUT</b>
	CHECKED						
	ENG APPR.						
	MFG APPR.						
	Q.A.			SIZE	DWG. NO.	REV	
	COMMENTS:	<b>11 GAGE</b>			<b>A</b>		
					SCALE: 1:8	WEIGHT:	SHEET 8 OF 11





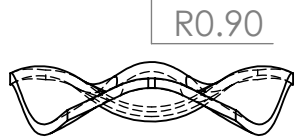
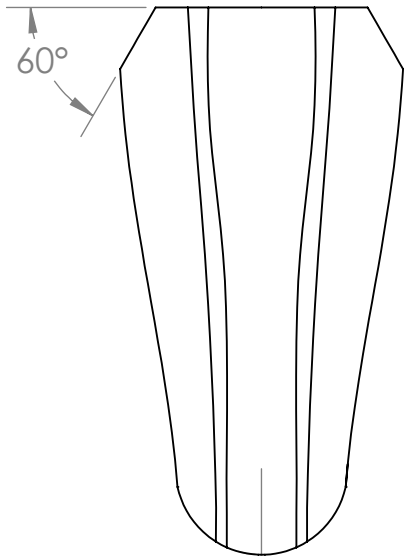
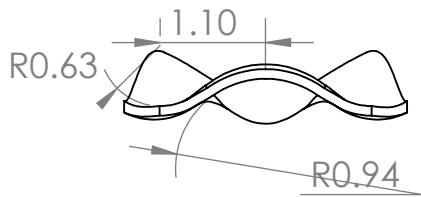

SECTION T-T  
SCALE 1 : 2



SECTION R-R  
SCALE 1 : 2



SECTION U-U  
SCALE 1 : 2

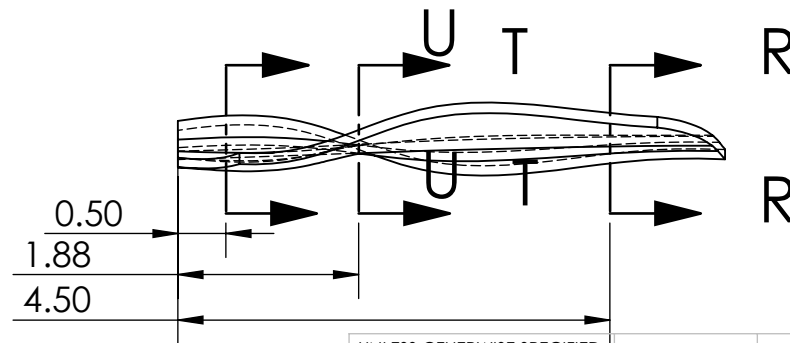

UNLESS OTHERWISE SPECIFIED:

DIMENSIONS ARE IN INCHES  
TOLERANCES:  
FRACTIONAL ±  
ANGULAR: MACH ± BEND ±  
TWO PLACE DECIMAL ±.01  
THREE PLACE DECIMAL ±.005

INTERPRET GEOMETRIC  
TOLERANCING PER:

MATERIAL **STEEL**

FINISH

DO NOT SCALE DRAWING

NAME

DATE

DRAWN

CHECKED

ENG APPR.

MFG APPR.

Q.A.

COMMENTS:

**11 GAGE**

**OSU HAND PLANTER**

TITLE:

**TIP SHOVEL FORM**

SIZE  
**A**

DWG. NO.

REV

SCALE: 1:8

WEIGHT:

SHEET 9 OF 11



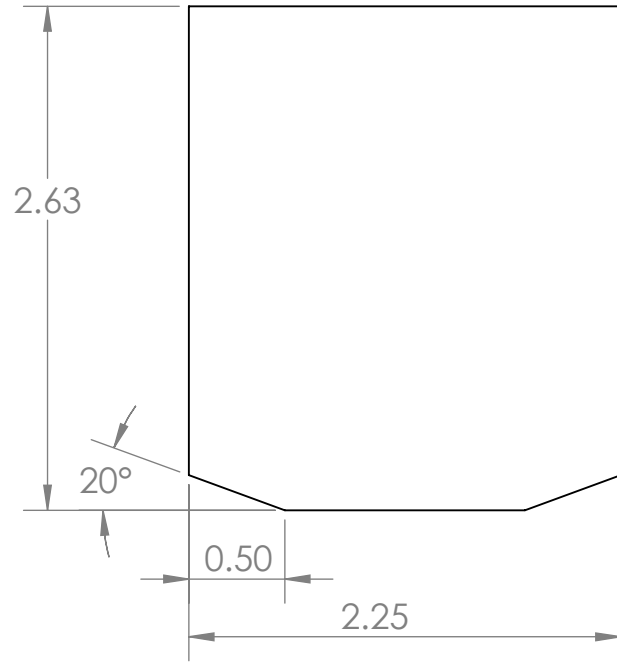
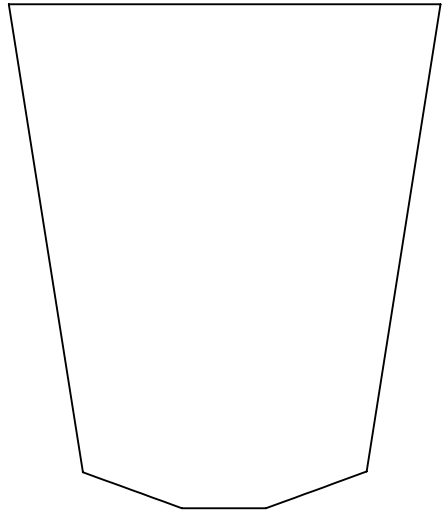

FLAT PATTERN

UNLESS OTHERWISE SPECIFIED:		NAME	DATE	OSU HAND PLANTER	
DIMENSIONS ARE IN INCHES		DRAWN			
TOLERANCES:		CHECKED			
FRACTIONAL ±		ENG APPR.			
ANGULAR: MACH ± BEND ±		MFG APPR.			
TWO PLACE DECIMAL ±.01		Q.A.		SIZE DWG. NO. REV	
THREE PLACE DECIMAL ±.005		COMMENTS:		11 GAGE	
INTERPRET GEOMETRIC TOLERANCING PER:				SCALE: 1:8 WEIGHT: SHEET 10 OF 11	
MATERIAL <b>STEEL</b>					
FINISH					
DO NOT SCALE DRAWING					



ITEM NO.	PART NUMBER	DESCRIPTION	QTY.
1	TIP COLLAR	2INCH SCHEDULE 160 PIPE X .75 LONG	1
2	TIP SHOVEL	3.5 X 6 X 11 GAGE STEEL	1
3	TIP DEFLECTOR	2 X 2 X 11 GAGE STEEL	1

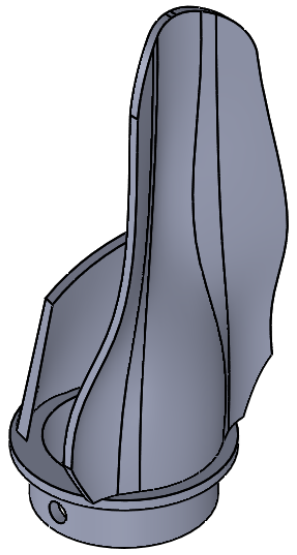
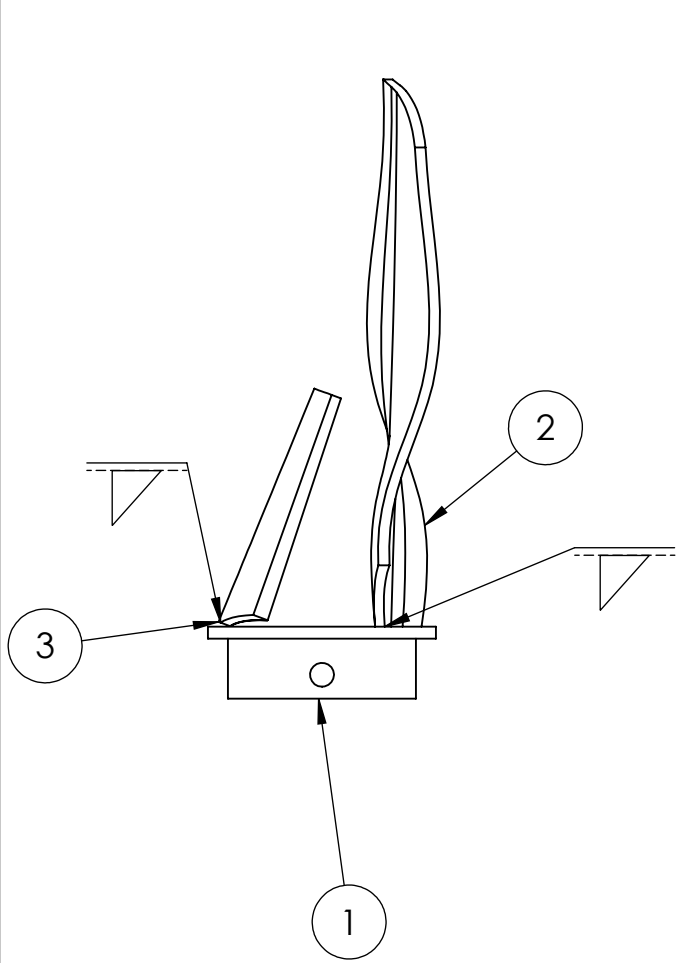

UNLESS OTHERWISE SPECIFIED:		NAME	DATE	OSU HAND PLANTER		
DIMENSIONS ARE IN INCHES		DRAWN				TITLE: TIP ASSEMBLY
TOLERANCES:		CHECKED				
FRACTIONAL ±		ENG APPR.				
ANGULAR: MACH ± BEND ±		MFG APPR.				
TWO PLACE DECIMAL ±.01		Q.A.		SIZE	DWG. NO.	REV
THREE PLACE DECIMAL ±.005		COMMENTS:		<b>A</b>		
INTERPRET GEOMETRIC TOLERANCING PER:				SCALE: 1:8	WEIGHT:	SHEET 11 OF 11
MATERIAL						
FINISH						
DO NOT SCALE DRAWING						

