

SECTION B-B

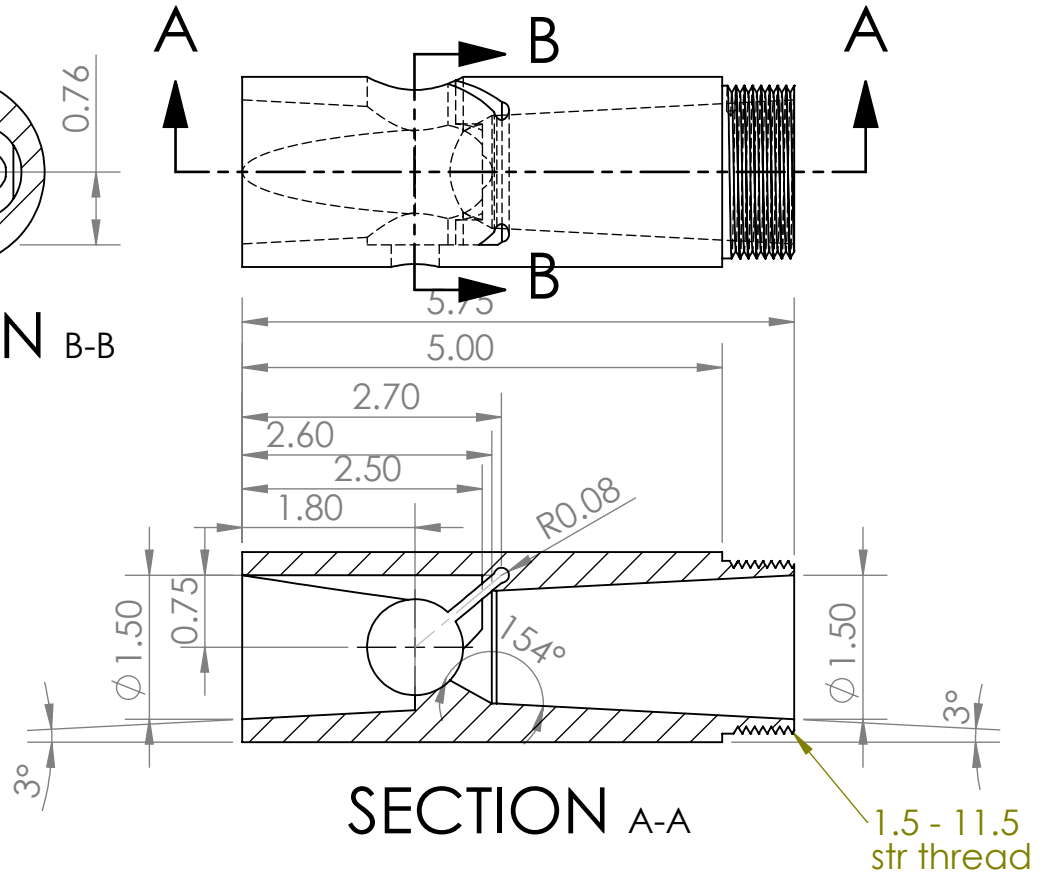
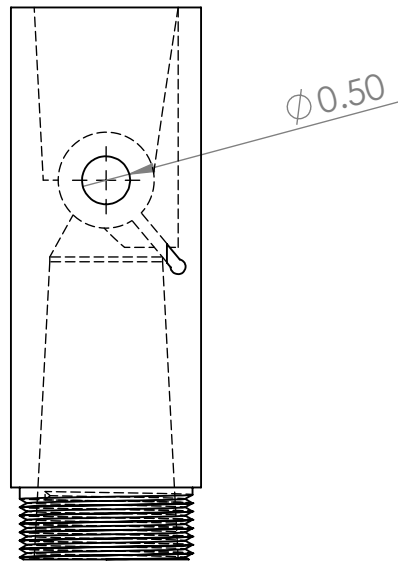

SECTION A-A

UNLESS OTHERWISE SPECIFIED:		NAME	DATE	BAE LAB	
DIMENSIONS ARE IN INCHES		DRAWN		TITLE:	
TOLERANCES:		CHECKED			
FRACTIONAL ±		ENG APPR.			
ANGULAR: MACH ± BEND ±		MFG APPR.			
TWO PLACE DECIMAL ±.01		Q.A.		SIZE	DWG. NO.
THREE PLACE DECIMAL ±.005		COMMENTS:		A	ext.3514
INTERPRET GEOMETRIC TOLERANCING PER:				SCALE: 1:2	WEIGHT:
MATERIAL				SHEET 1 OF 1	
FINISH					
DO NOT SCALE DRAWING					